

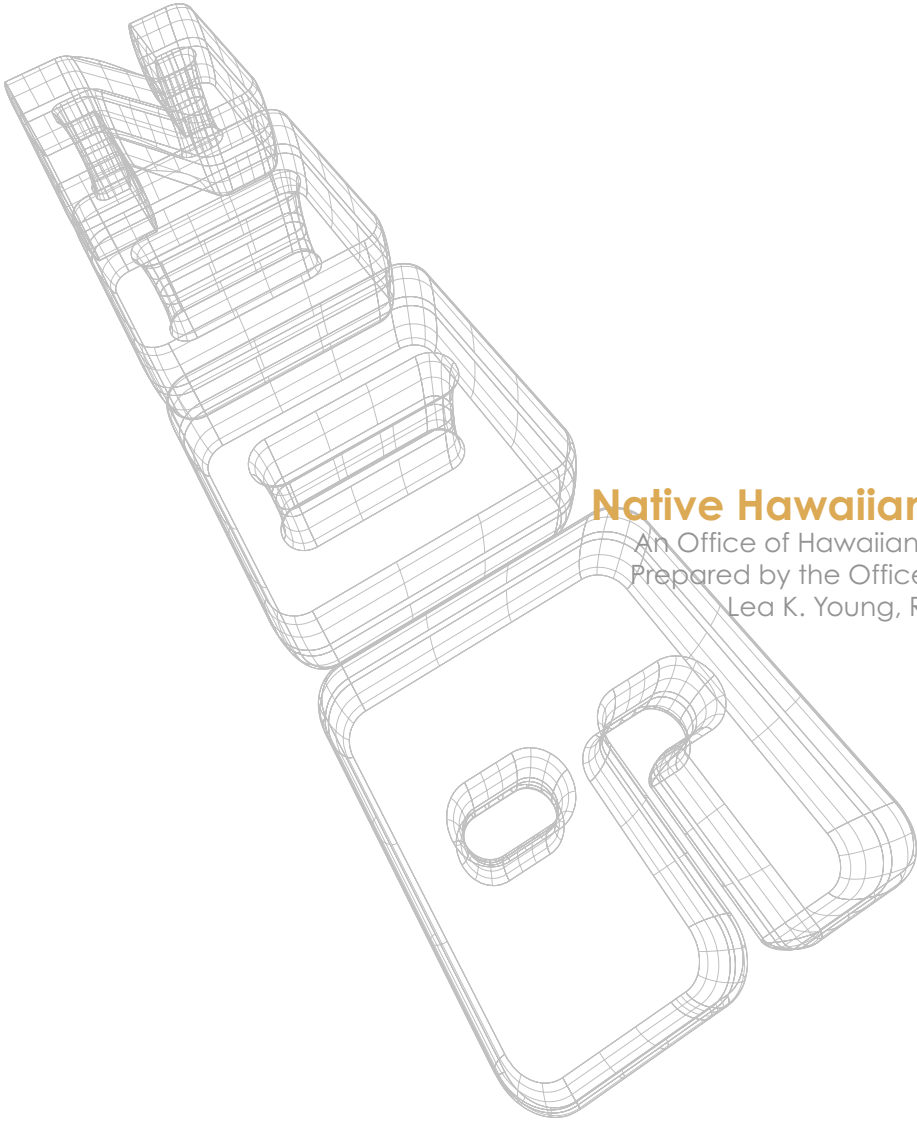

Native Hawaiian Data Book
An Office of Hawaiian Affairs Publication



Native Hawaiian Data Book

An Office of Hawaiian Affairs Publication
Prepared by the Office of Board Services
Lea K. Young, Research Specialist

MISSION STATEMENT

To mālama (protect) Hawai'i's people and environmental resources and OHA's assets, toward ensuring the perpetuation of the culture, the enhancement of lifestyle and the protection of entitlements of Native Hawaiians, while enabling the building of a strong and healthy Hawaiian people and nation, recognized nationally and internationally.

OFFICE OF HAWAIIAN AFFAIR: BOARD OF TRUSTEES

Haunani Apoliona, MSW
Chairperson
Trustee, At-large

John D. Waihe'e IV
Vice Chair
Trustee, At-large

Rowena Akana
Trustee, At-large

Dante Keala Carpenter
Trustee, O'ahu

Donald B. Cataluna
Trustee, Kaua'i & Ni'ihau

Linda K. Dela Cruz
Trustee, Hawai'i

Colette Y. Machado
Trustee, Moloka'i & Lāna'i

Boyd P. Mossman
Trustee, Maui

Oswald Stender
Trustee, At-large

ADMINISTRATION

Clyde W. Nāmu'o
Administrator

Ron Mun
Deputy Administrator

Mark B. Glick
Director, OBS

On behalf of the Office of Hawaiian Affairs Board of Trustees, it is my pleasure to present the 2006 edition of the "Native Hawaiian Data Book", a comprehensive statistical profile of the current status of the Native Hawaiian community.

This data is gathered and compiled to assist community organizations to develop and strengthen service programs and community action projects to effectively meet the needs of Native Hawaiians. Data and information are key components in protecting and perpetuating the health and well-being of Native Hawaiians and ensuring the Native Hawaiian culture thrives for generations to come as the foundation of the emerging Native Hawaiian nation.

The information in this 2006 edition of the "Native Hawaiian Data Book" was gathered from sources including: The Kamehameha Schools, Policy Analysis and System Evaluation (PASE); the State of Hawai'i Departments of Health, Public Safety, Hawaiian Home Lands, Human Services, Business, Economic Development and Tourism; the University of Hawai'i and the United States Department of Commerce, Bureau of the Census.

This 2006 edition also includes a resource list for health, human services, education, and also GIS maps to illustrate the demographic distribution of the Native Hawaiian population in the state of Hawai'i.

As the Office of Hawaiian Affairs marks its 25th year of serving the Native Hawaiian community, our staff continues to work diligently to advance the betterment of Native Hawaiians. Baseline data and information will continue to chart our improvements and give direction to future efforts.

We trust that you will continue to find the "Native Hawaiian Data Book" an important resource in your efforts to assist the Native Hawaiian community.

'O wau nō me ka ha'aha'a,

A handwritten signature in black ink, reading "Haunani Apoliona". The signature is fluid and cursive, with a long horizontal flourish extending to the right.

Haunani Apoliona, MSW, Trustee
Chairperson, Board of Trustees

A MESSAGE FROM THE ADMINISTRATOR

November 1, 2005

Aloha kākou,

I am pleased to present to you the 2006 Native Hawaiian Data Book. This updated compilation of demographic data does much more than fulfill a statutory obligation of the Office of Hawaiian Affairs. Whether you are a kama'āina or a visitor, the Data Book offers a meaningful service to all who wish to know about the business, cultural, and human affairs of the indigenous people of Hawaii.

New features make the 2006 Data Book unique – such as GIS maps, more in-depth data on education, and an exciting new website version. When you go to www.oha.org and click on the 2006 Data Book, you will find all the detailed data found in the hard copy version, in addition to links to data sources and other related sites.

So it is fitting, on our silver anniversary, we introduce the updated 2006 Native Hawaiian Data Book as the official Office of Hawaiian Affairs' publication providing the most comprehensive snapshot of the more than 401,000 Hawaiians in Hawai'i and on the continent.

'O wau iho nō me ke aloha,

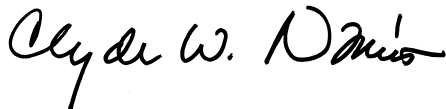
A handwritten signature in black ink that reads "Clyde W. Nāmu`o". The signature is written in a cursive style with a prominent initial "C" and a stylized "Nāmu`o".

Clyde W. Nāmu`o
Administrator

INTRODUCTION

The 2006 edition of the Native Hawaiian Data Book is a comprehensive collection of statistics of Native Hawaiians in Hawai'i that may be used as both a statistical reference and as a guide to other statistical publications and sources. This publication represents a part of the continuous effort by the Office of Hawaiian Affairs to provide informational services to other governmental agencies and the general public.

Consistent with HRS Chapter 10, OHA's goal was to compile basic demographic information and identify the physical and sociological needs of the Hawaiian people. Users will find an insightful collection and presentation of the latest descriptive data on Hawaiians in the State of Hawai'i. Under one cover, this data book provides the most current information on Hawaiians in several topic areas such as: population, land, education, public safety, health, vital statistics, and social welfare. While there were no attempts to interpret the data in depth, areas of interest were highlighted or graphed to bring attention to that information.

Caution is advised when comparing or correlating information within this book. The methodologies used to define and compile ethnicity information vary between researchers and demographers statewide. These can be reviewed in the appendix of this book. Sources should be contacted directly to clarify the context of the information viewed in this book.

For previous years' information, please see the 2002 Native Hawaiian Data Book and other related data links on OHA's website at www.oha.org.

TABLE OF CONTENTS

DEMOGRAPHICS	15
Population distribution by age group by state	18
Kaua'i County GIS Map	21
O'ahu GIS Map	22
Maui County GIS Map	23
Hawai'i County GIS Map	24
VITAL STATISTICS	
Marriages by Ethnicity of Groom and Ethnicity of Bride: 2003 and 2004	25
Resident Live Births by Resident County and Ethnicity of Mother: 2003 and 2004	26
Resident Live Births where Mother is Unmarried by Ethnicity of Child: 2003 and 2004	27
Resident Live Births where Mother is Unmarried by Ethnicity of Mother: 2003 and 2004	28
Resident Deaths by Ethnicity of Decedent: 2003 and 2004	29
Resident Abortions by Ethnicity of Patients and Age of Patient: 2003 and 2004	30
Resident Infant Deaths by Ethnicity of Mother: 2003 and 2004	31
Resident Infant Deaths by Ethnicity of Infant: 2003 and 2004	32
Vital Indicators of Maternal and Child Health ranked by Ethnicity of Mother Residents: 2003 and 2004	34
LAND HOLDINGS	37
Estimated Acreage of Land Usage: December 31, 2003	40
Landowners in Hawai'i: 2000 – 2003	41
Queen Lili'uokalani Trust Land Holdings: 2004	42
Queen Lili'uokalani Trust Usage of Land Holdings: 2004	
Lunalilo Trust Land Holdings: 2004	
Kamehameha Schools Land Holdings	43
Department of Hawaiian Homelands Land Use Summary by Island in Acres: 2004	
Department of Hawaiian Homelands Income Summary by Use and Island: 2004	
EDUCATION	45
Educational Attainment of Individuals 25 years and older: Census 2000	48
Educational Attainment of Individuals 18 years and older: HHS 2003	52
Kamehameha Schools' Official Enrollment: SY 2003-04	53
Hawaiian Students in Hawai'i's Department of Education by District: 2002-03	55
DOE Statewide Enrollment by Grade Level: 2002-03, 2003-04	56
DOE Enrollment – Honolulu District: 2002-03, 2003-04	57
DOE Enrollment – Central O'ahu District: 2002-03, 2003-04	58
DOE Enrollment – Leeward O'ahu District: 2002-03, 2003-04	59

DOE Enrollment – Windward O‘ahu District: 2002-03, 2003-04	60
DOE Enrollment – Kaua‘i District: 2002-03, 2003-04	61
DOE Enrollment – Maui District: 2002-03, 2003-04	62
DOE Enrollment – Hawai‘i Island District: 2002-03, 2003-04	63
DOE Lunch Status Data by District: SY 2002-03	64
DOE Standardized Test Scores - Statewide: SY 2001-02, 2002-03	65
DOE Standardized Test Scores - Honolulu District: SY 2001-02, 2002-03	67
DOE Standardized Test Scores - Central District: SY 2001-02, 2002-03	69
DOE Standardized Test Scores - Leeward District: SY 2001-02, 2002-03	71
DOE Standardized Test Scores - Windward District: SY 2001-02, 2002-03	73
DOE Standardized Test Scores - Kaua‘i District: SY 2001-02, 2002-03	75
DOE Standardized Test Scores - Maui District: SY 2001-02, 2002-03	77
DOE Standardized Test Scores - Maui Island: SY 2002-03	79
DOE Standardized Test Scores - Lāna‘i Island: SY 2002-03	80
DOE Standardized Test Scores - Moloka‘i Island: SY 2002-03	81
DOE Standardized Test Scores - Hawai‘i Island District: SY 2001-02, 2002-03	82
DOE Standardized Test Scores - East Hawai‘i Island: SY 2002-03	84
DOE Standardized Test Scores - West Hawai‘i Island: SY 2002-03	85
Ethnic Background of Credit Students by Campus – University of Hawai‘i: Fall 2003 and 2004	86
University of Hawai‘i Degrees and Certificates Earned by Degree Type and Ethnicity: 2002-03, 2003-04	88
Ethnic Background of University of Hawai‘i Instructional Faculty and Community Colleges Personnel: Fall 2002 and 2003	90
Education Resources	92
HEALTH	95
Selected Chronic Conditions by Ethnicity – Total Number and Prevalence per 1,000 persons in Hawai‘i: Hawai‘i Health Survey (HHS) 2002	98
Number and Percent Overweight (including Obese) by County and Ethnicity: HHS 2002	99
Adult Asthma Status: 2003	100
High Blood Pressure Risk Factor: 2003	101
High Cholesterol Risk Factor: 2003	
Smoking Status: 2003	102
General Health Status: 2003	103
Health Insurance Status: 2003	104
Hawaiian Students' Alcohol, Tobacco, and Other Drug Use: 2002	106
Hawaiian Students' Antisocial Behaviors: 2002	107
Health Resources	108

HUMAN SERVICES	111
Poverty Status: Census 2000	114
Number and Percent Uninsured by County and Ethnicity: HHS 2002	117
Ethnicity of Individuals Served by TANF/TANOF Programs: FY 2002	118
Composition of TANF/TANOF Households: FY 2002	
Heads of Households of TANF/TANOF Families: FY 2002	119
Ethnic Distribution of Employment and Training Clients: FY 2002	
Ethnic Distribution of First to Work Clients: FY 2002	120
Ethnicity of Individuals Served by General Assistance Program: FY 2002	121
Typical Characteristics of Individuals Served by General Assistance Program: FY 2002	
Human Services Resources	122
HOUSING	125
Household Size and Type: HHS 2003	128
Department of Hawaiian Homelands Number of Applicants by County: 2003	130
DHHL Home Ownership Rates Among Applicants: 2003	
DHHL Applicants' Preference after Qualifications by Island Preference	131
DHHL Applications by Island of Preference: 2003	132
DHHL Award Preferences of Applicants: 2003	
DHHL Applicants Below 80% HUD Median Income Guidelines: 2003	133
DHHL Applicants' Location Preferences – First and Second Choices: 2003	134
DHHL Qualifications by Island of Residence: 2003	135
DHHL Total Number of Applicants by Preference After Qualification: 2003	
Housing Resources	136
ECONOMIC DEVELOPMENT	137
Comparison of Employment Status for Native Hawaiian and U.S. Populations: Census 2000	140
Native Hawaiian Employment Status: Census 2000	141
Native Hawaiian Occupation, Industry, and Class: Census 2000	145
Distribution of Native Hawaiian Household Incomes by Island: Census 2000	152
Native Hawaiian Income in 1999: Census 2000	153
Household Income: HHS 2003	160
Native Hawaiian-owned Firms by Geographic Location: 1997 Economic Census	162
States with Largest Number of Hawaiian-owned Firms: 1997 Economic Census and Census 2000	163
Native Hawaiians in Business in the USA: 1997 Economic Census	
Distribution of Native Hawaiian-owned Firms by Industry: 1997 Economic Census	164
Native Hawaiian-owned Firms in Service Industry by Sub-type: 1997 Economic Census	
Economic Development Resources	165

PUBLIC SAFETY	167
Distribution of Inmate Population by Ethnic Group or Race in Hawai'i Correctional Facilities: as of June 30, 2004 and June 30, 2005	170
Distribution of Inmate Population by Ethnic Group or Race in Out-of-State Correctional Facilities: as of June 30, 2004 and June 30, 2005	172
Statewide Adult and Juvenile Arrests by Index Offenses: 2003	174
Statewide Race/Ethnicity of Murder Victims and Known Offenders: 2003	175
Statewide Race/Ethnicity of Adults Arrested for Index Offenses: 2003	176
Statewide Race/Ethnicity of Juveniles Arrested for Index Offenses: 2003	177
Statewide Race/Ethnicity of Adults Arrested for Part II Offenses: 2003	178
Statewide Race/Ethnicity of Juveniles Arrested for Part II Offenses: 2003	181
C&C of Honolulu Race/Ethnicity of Adults Arrested for Index Offenses: 2003	184
C&C of Honolulu Race/Ethnicity of Juveniles Arrested for Index Offenses: 2003	185
C&C of Honolulu Race/Ethnicity of Adults Arrested for Part II Offenses: 2003	186
C&C of Honolulu Race/Ethnicity of Juveniles Arrested for Part II Offenses: 2003	189
County of Kaua'i Race/Ethnicity of Adults Arrested for Index Offenses: 2003	192
County of Kaua'i Race/Ethnicity of Juveniles Arrested for Index Offenses: 2003	193
County of Kaua'i Race/Ethnicity of Adults Arrested for Part II Offenses: 2003	194
County of Kaua'i Race/Ethnicity of Juveniles Arrested for Part II Offenses: 2003	197
Maui County Race/Ethnicity of Adults Arrested for Index Offenses: 2003	200
Maui County Race/Ethnicity of Juveniles Arrested for Index Offenses: 2003	201
Maui County Race/Ethnicity of Adults Arrested for Part II Offenses: 2003	202
Maui County Race/Ethnicity of Juveniles Arrested for Part II Offenses: 2003	205
Hawai'i County Race/Ethnicity of Adults Arrested for Index Offenses: 2003	208
Hawai'i County Race/Ethnicity of Juveniles Arrested for Index Offenses: 2003	209
Hawai'i County Race/Ethnicity of Adults Arrested for Part II Offenses: 2003	210
Hawai'i County Race/Ethnicity of Juveniles Arrested for Part II Offenses: 2003	213
APPENDIX	217
DEFINITIONS	227
STATISTICAL SOURCES	241
ACKNOWLEDGEMENTS	245

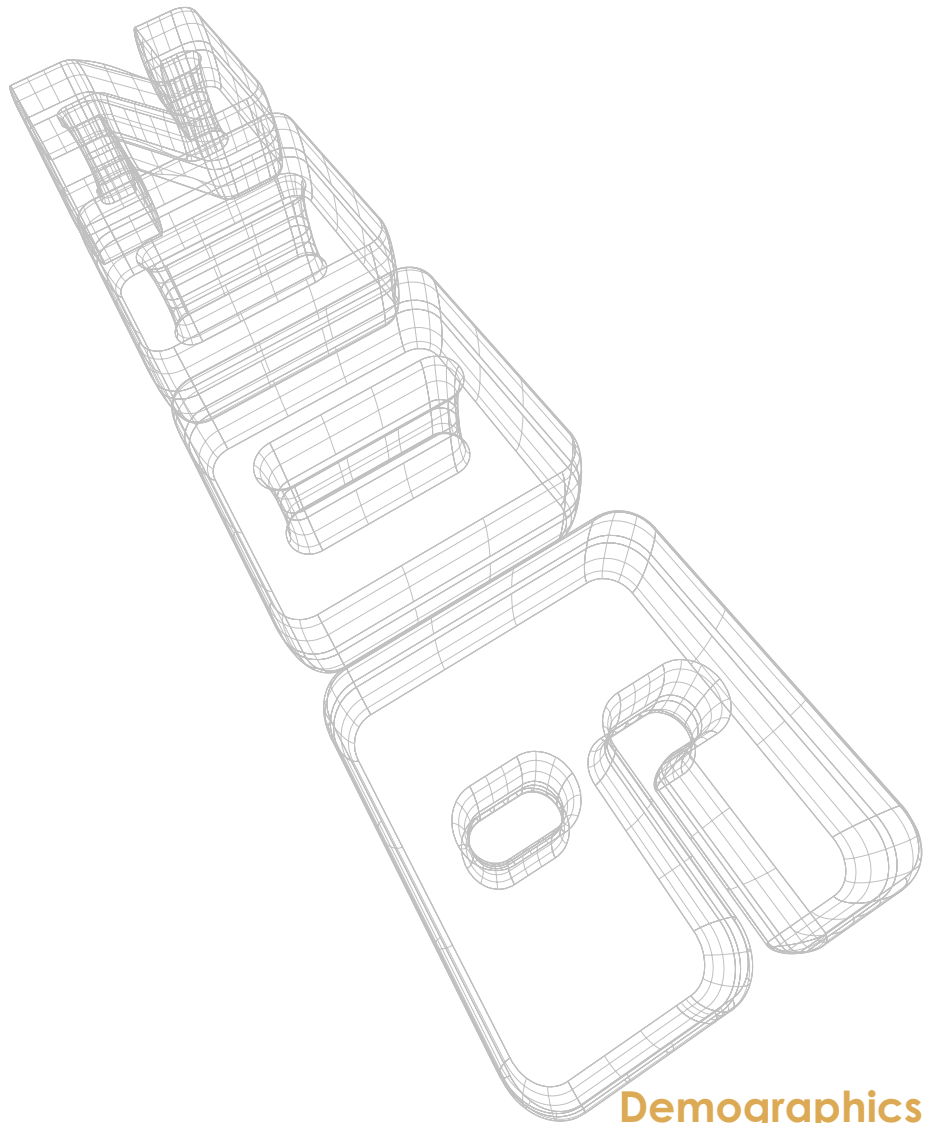

Demographics

POPULATION AND VITAL STATISTICS

Within the last decade, the U.S. Census Bureau has continued to take great strides to ensure adequate representation of Native Hawaiian issues among their various data products. For the first time in history, individuals could select more than one race for Census 2000. This meant more accurate counts for Native Hawaiians, who could now be separated from the category, "Native Hawaiian and Other Pacific Islander" (NHOPI) by being counted as Native Hawaiian alone or in combination with other races.

According to the U.S. Census 2000 data, there are approximately 401,162 Native Hawaiians in Hawai'i and on the continent. In the State of Hawai'i alone, there are over 239,655 Native Hawaiians, representing 60% of the total population of Native Hawaiians in the United States. Population forecasts suggest that while the Native Hawaiian population continues to steadily increase, the population of Native Hawaiians in Hawai'i is slowly decreasing due to the increasing cost of living and limited economic opportunities.

Along with the U.S. Census Bureau, the State of Hawai'i Department of Health also plays a crucial role in measuring the vital statistics of Native Hawaiians through birth, death, and marriage data collected by the Office of Health Status Monitoring (OHSM). Other data collection methods such as the Hawai'i Health Survey (HHS) and Behavioral Risk Factor Surveillance System (BRFSS) allow the Department of Health to provide race specific estimates regarding the prevalence of chronic conditions, general health, and risk factors associated with chronic conditions for Native Hawaiians and other ethnicities in Hawai'i.

While the data is far from perfect, the U.S. Census Bureau, in conjunction with various state agencies and Native Hawaiian organizations, continue to work together to ensure better success in greater sampling coverage of the Native Hawaiian population to help increase resource leveraging and research purposes.

Hawaiians in the USA: U.S. Census 2000

State / Region	>1 - 17 years	18 - 65 years	>65	TOTAL
PACIFIC				
Alaska	805	1,036	37	1,878
California	20,662	36,235	3,151	60,048
Hawai'i	92,219	132,805	14,631	239,655
Oregon	2,309	3,832	225	6,366
Washington	4,913	8,204	390	13,507
Mountain				
Nevada	2,739	5,125	400	8,264
Arizona	1,840	2,893	173	4,906
New Mexico	495	714	52	1,261
Colorado	1,419	2,468	103	3,990
Utah	1,561	1,992	89	3,642
Wyoming	93	130	10	233
Idaho	448	645	46	1,139
Montana	193	305	31	529
W. NORTH CENTRAL				
North Dakota	48	77	7	132
South Dakota	86	115	6	207
Nebraska	179	349	15	543
Kansas	377	576	44	997
Minnesota	463	1,012	51	1,526
Iowa	248	432	19	699
Missouri	568	974	78	1,620
W. SOUTH CENTRAL				
Texas	2,665	4,777	333	7,775
Oklahoma	683	1,173	76	1,932
Arkansas	245	424	49	718
Louisiana	275	526	49	850
EAST NORTH CENTRAL				
Wisconsin	384	708	51	1,143

Illinois	795	1,571	140	2,506
Indiana	469	867	66	1,402
Ohio	724	1,168	97	1,989
Michigan	728	1,243	87	2,058

EAST SOUTH CENTRAL

Kentucky	274	530	41	845
Tennessee	437	797	68	1,302
Mississippi	150	326	29	505
Alabama	253	517	63	833

SOUTH ATLANTIC

Georgia	734	1,362	87	2,183
Florida	1,725	3,257	303	5,285
South Carolina	363	640	53	1,056
North Carolina	830	1,481	79	2,390
Virginia	932	1,783	80	2,795
West Virginia	76	168	20	264
District of Columbia	36	185	10	231
Maryland	488	894	93	1,475
Delaware	46	85	9	140
Middle Atlantic				
New York	1,089	2,414	255	3,758
Pennsylvania	686	1,232	133	2,051
New Jersey	477	930	94	1,501
North Atlantic				
Maine	90	141	12	243
Vermont	21	45	10	76
New Hampshire	92	160	14	266
Massachusetts	373	915	68	1,356
Rhode Island	98	197	16	311
Connecticut	256	484	41	781

TOTAL **148,159** **230,919** **22,084** **401,162**

To better illustrate the Native Hawaiian population in Hawai'i, Geographic Information Systems (GIS) maps are provided for each island and moku. New to the Native Hawaiian Data Book, each map is broken down by the percent of Native Hawaiians located by Hawaiian Homelands, zipcode, moku, and census tract. Data sources for these maps include the U.S. Census Bureau Census 2000 and the Hawai'i State GIS.

Please note the following disclaimer:

There are no expressed warranties associated with the release of this data. Specifically, no warranty is made that the GIS data or any subsequent updates will be error free and no warranty is made regarding the positional or thematic accuracy of the GIS data. The GIS data and any features it depicts do not represent or confer any legal rights, privileges, benefits, boundaries, or claims of any kind. The Office of Hawaiian Affairs encourages users to report any discrepancies or errors found.

Kaua'i County

Hawaiian Population



Percent Hawaiians in 2000



Hawaiian Homelands

Census Tracts

Zipcode

Moku

NOTE:
"Natural breaks" classification normalized by the total number of Hawaiians in the State.

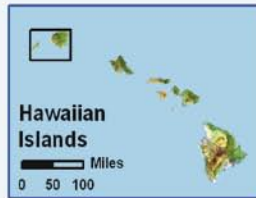
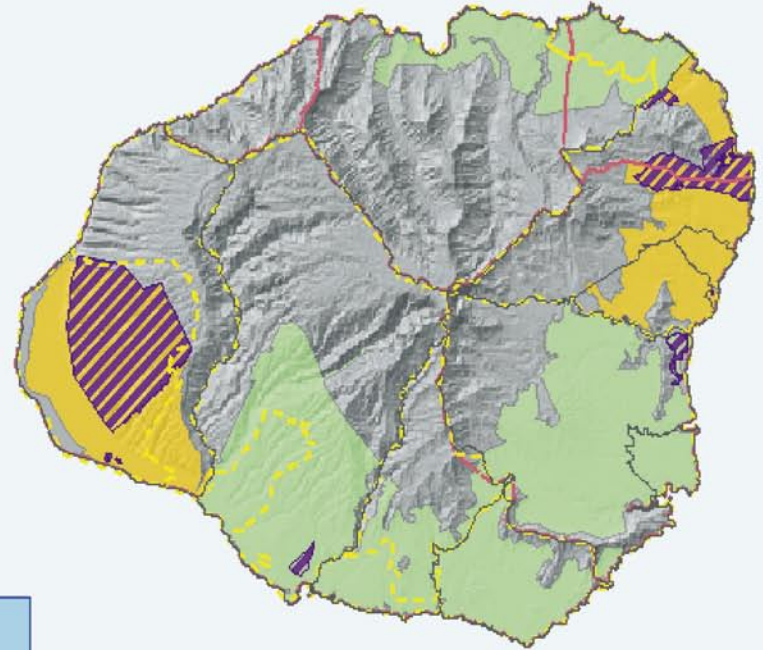

Kaua'i Moku and Ni'ihau

Hawaiian Population



Sources:
Census tract, Hawaiian Homeland, and Zipcode boundaries from Hawai'i State GIS, Feb. 2002.
2000 Hawaiian population statistics from U.S. Census Bureau, Mar. 2003.



Disclaimer:
There are no expressed warranties associated with the release of this data. Specifically, no warranty is made that the GIS data or any subsequent updates will be error free and no warranty is made regarding the positional or thematic accuracy of the GIS data. The GIS data and any features it depicts do not represent or confer any legal rights, privileges, benefits, boundaries or claims of any kind. The Office of Hawaiian Affairs encourages users to report any discrepancies or errors found.

O'ahu

Hawaiian Population



NOTE:
 "Natural breaks" classification normalized by the total number of Hawaiians in the State.

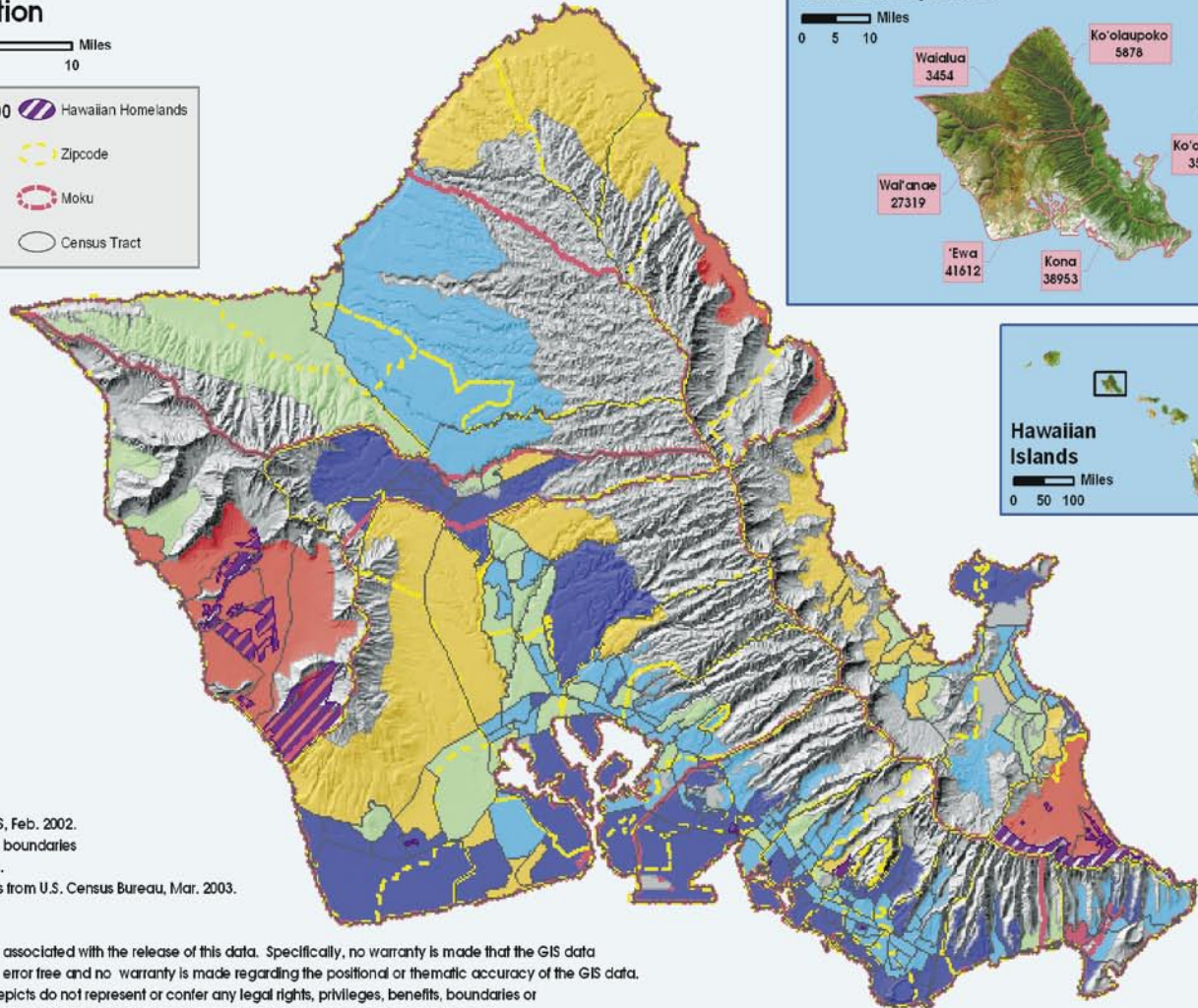

O'ahu Moku

Hawaiian Population

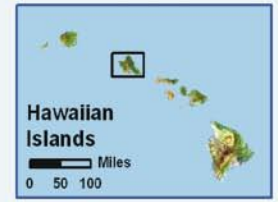
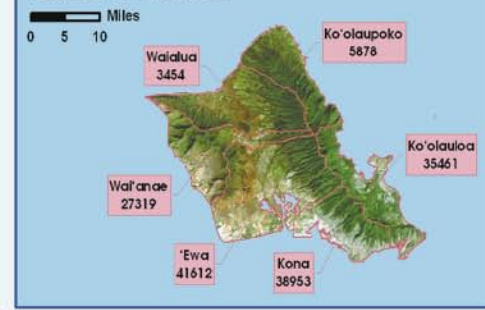

Sources:
 Census tract from Hawai'i State GIS, Feb. 2002.
 Hawaiian Homeland, and Zipcode boundaries from Hawai'i State GIS, Feb. 2002.
 2000 Hawaiian population statistics from U.S. Census Bureau, Mar. 2003.

Disclaimer:
 There are no expressed warranties associated with the release of this data. Specifically, no warranty is made that the GIS data or any subsequent updates will be error free and no warranty is made regarding the positional or thematic accuracy of the GIS data. The GIS data and any features it depicts do not represent or confer any legal rights, privileges, benefits, boundaries or claims of any kind. The Office of Hawaiian Affairs encourages users to report any discrepancies or errors found.

Maui Moku, Moloka'i, and Lāna'i Hawaiian Population

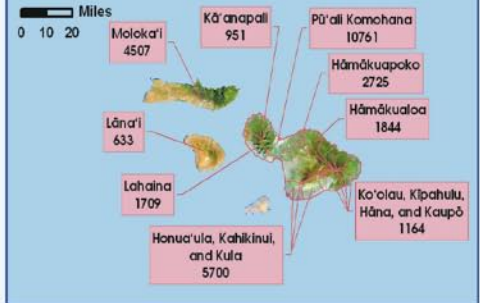

Maui County Hawaiian Population



NOTE:
 "Natural breaks" classification normalized by the total number of Hawaiians in the State.

Sources:
 Census tract from Hawai'i State GIS, Feb. 2002.
 Hawaiian Homelands, and Zipcode boundaries from Hawai'i State GIS, Feb. 2002.
 2000 Hawaiian population statistics from U.S. Census Bureau, Mar. 2003.

Disclaimer:
 There are no expressed warranties associated with the release of this data. Specifically, no warranty is made that the GIS data or any subsequent updates will be error free and no warranty is made regarding the positional or thematic accuracy of the GIS data. The GIS data and any features it depicts do not represent or confer any legal rights, privileges, benefits, boundaries or claims of any kind. The Office of Hawaiian Affairs encourages users to report any discrepancies or errors found.

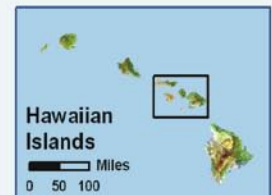

Hawai'i County

Hawaiian Population



NOTE:
 "Natural breaks" classification normalized by the total number of Hawaiians in the State.

Sources:
 Census tract from Hawai'i State GIS, Feb. 2002
 Hawaiian Homeland, and Zipcode boundaries from Hawai'i State GIS, Feb. 2002.
 2000 Hawaiian population statistics from U.S. Census Bureau, Mar. 2003.

Disclaimer:
 There are no expressed warranties associated with the release of this data. Specifically, no warranty is made that the GIS data or any subsequent updates will be error free and no warranty is made regarding the positional or thematic accuracy of the GIS data. The GIS data and any features it depicts do not represent or confer any legal rights, privileges, benefits, boundaries or claims of any kind. The Office of Hawaiian Affairs encourages users to report any discrepancies or errors found.

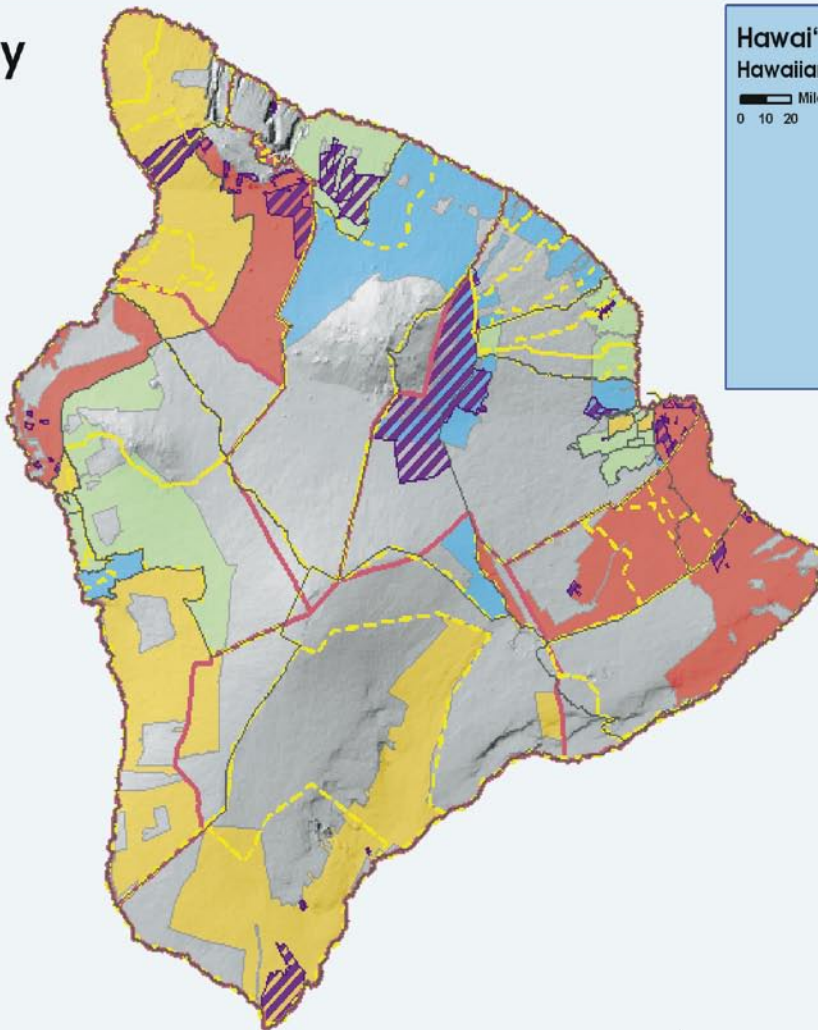

Hawai'i Moku

Hawaiian Population

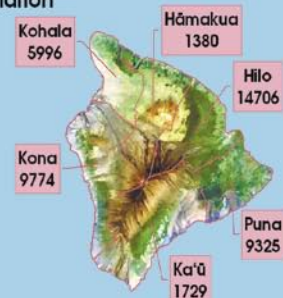
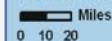

Marriages by Ethnicity of Groom and Ethnicity of Bride: State of Hawai'i, 2003

Ethnicity	Groom	Bride
Caucasian	18,021	16,680
Hawaiian / Part Hawaiian	1,683	1,758
Chinese	620	886
Filipino	1,248	1,855
Japanese	1,493	1,937
All Others	4,430	4,379
TOTAL	27,495	27,495

Marriages by Ethnicity of Groom and Ethnicity of Bride: State of Hawai'i, 2004

Ethnicity	Groom	Bride
Caucasian	18,936	17,600
Hawaiian / Part Hawaiian	1,669	1,732
Chinese	657	919
Filipino	1,445	1,954
Japanese	1,451	1,973
All Others	4,685	4,665
TOTAL	28,843	28,843

Source: Office of Health Status Monitoring, Hawai'i State Department of Health

Resident Live Births by Resident County and Ethnicity of Mother: State of Hawai'i, 2003

Ethnicity of Mother	Resident County of Mother				
	Hawai'i	Honolulu	Kaua'i	Maui	Total
Caucasian	471	2,850	220	531	4,072
Hawaiian / Part Hawaiian	922	3,119	244	589	4,874
Chinese	24	559	12	13	608
Filipino	302	2,531	230	428	3,491
Japanese	184	1,823	55	140	2,202
All Others	246	2,336	53	182	2,817
TOTAL	2,149	13,218	814	1,883	18,064

Resident Live Births by Resident County and Ethnicity of Mother: State of Hawai'i, 2004

Ethnicity of Mother	Resident County of Mother				
	Hawai'i	Honolulu	Kaua'i	Maui	Total
Caucasian	488	2,765	204	572	4,029
Hawaiian / Part Hawaiian	1,017	3,125	295	592	5,029
Chinese	26	612	11	20	669
Filipino	283	2,492	221	427	3,423
Japanese	169	1,806	60	116	2,151
All Others	246	2,490	34	168	2,938
TOTAL	2,229	13,290	825	1,895	18,239

Source: Office of Health Status Monitoring, Hawai'i State Department of Health

Resident Live Births where Mother is Unmarried by Ethnicity of Child:
State of Hawai'i, 2003

Ethnicity of Child	Number
Caucasian	400
Hawaiian / Part Hawaiian	3,370
Chinese	48
Filipino	957
Japanese	250
All Others	1,022
TOTAL	6,047

Resident Live Births where Mother is Unmarried by Ethnicity of Child:
State of Hawai'i, 2004

Ethnicity of Child	Number
Caucasian	463
Hawaiian / Part Hawaiian	3,548
Chinese	55
Filipino	921
Japanese	267
All Others	1,039
TOTAL	6,293

Source: Office of Health Status Monitoring, Hawai'i State Department of Health

**Resident Live Births where Mother is Unmarried by Ethnicity of Mother:
State of Hawai'i, 2003**

Ethnicity of Mother	Number
Caucasian	655
Hawaiian / Part Hawaiian	2,686
Chinese	72
Filipino	1,213
Japanese	389
All Others	1,032
TOTAL	6,047

**Resident Live Births where Mother is Unmarried by Ethnicity of Mother:
State of Hawai'i, 2004**

Ethnicity of Mother	Number
Caucasian	728
Hawaiian / Part Hawaiian	2,854
Chinese	82
Filipino	1,164
Japanese	390
All Others	1,075
TOTAL	6,293

Source: Office of Health Status Monitoring, Hawai'i State Department of Health

Resident Deaths by Ethnicity of Decedent: State of Hawai'i, 2003

Ethnicity of Decedent	Number
Caucasian	2,350
Hawaiian / Part Hawaiian	1,445
Chinese	587
Filipino	1,238
Japanese	2,712
All Others	518
TOTAL	8,850

Resident Deaths by Ethnicity of Decedent: State of Hawai'i, 2004

Ethnicity of Decedent	Number
Caucasian	2,347
Hawaiian / Part Hawaiian	1,459
Chinese	601
Filipino	1,197
Japanese	2,737
All Others	547
TOTAL	8,888

Source: Office of Health Status Monitoring, Hawai'i State Department of Health

Resident Abortions by Ethnicity of Patients and Age of Patient, State of Hawai'i, 2003

Age of Patient	By Ethnicity of Patient					
	Caucasian	Hawaiian/ Part Hawaiian	Filipino	Japanese	All Others	TOTAL
Under 17	51	98	88	42	74	353
18 - 19	96	93	90	54	107	440
20 - 24	345	228	216	116	268	1,173
25 - 29	179	148	109	56	208	700
30 - 34	131	73	77	63	117	461
35 - 39	93	44	60	39	84	320
40+ / Unknown	44	16	25	19	30	134
TOTAL	939	700	665	389	888	3,581

Resident Abortions by Ethnicity of Patients and Age of Patient, State of Hawai'i, 2004

Age of Patient	By Ethnicity of Patient						
	Caucasian	Hawaiian/ Part Hawaiian	Chinese	Filipino	Japanese	All Others	TOTAL
Under 17	67	80	9	62	45	65	328
18 - 19	87	91	7	71	31	80	367
20 - 24	329	267	29	196	95	235	1,151
25 - 29	222	157	20	118	60	156	733
30 - 34	133	84	19	78	35	98	447
35 - 39	76	39	12	54	29	57	267
40+ / Unknown	50	13	12	25	16	33	149
TOTAL	964	731	108	604	311	724	3,442

Source: Office of Health Status Monitoring, Hawai'i State Department of Health

Resident Infant Deaths by Ethnicity of Mother: State of Hawai'i, 2003

Ethnicity of Decedent	Number
Caucasian	16
Hawaiian / Part Hawaiian	48
Filipino	27
Japanese	14
All Others	26
TOTAL	131

Resident Infant Deaths by Ethnicity of Mother: State of Hawai'i, 2004

Ethnicity of Decedent	Number
Caucasian	17
Hawaiian / Part Hawaiian	30
Filipino	16
Japanese	11
All Others	23
TOTAL	97

Source: Office of Health Status Monitoring, Hawai'i State Department of Health

Resident Infant Deaths by Ethnicity of Infant and Age of Infant: State of Hawai'i, 2003

Ethnicity of Infant	Age of Infant				TOTAL
	1 Day <	1-6 Days	7-27 Days	28 Days to 11 Months	
Caucasian					
#	5	*	*	*	10
Rate/100 Live Births	1.6	0.3	0.7	0.7	3.3
Hawaiian / Part Hawaiian					
#	26	10	9	22	67
Rate/100 Live Births	4.0	1.5	1.4	3.4	10.2
Filipino					
#	8	*	*	*	19
Rate/100 Live Births	2.6	1.3	1.0	1.3	6.2
Japanese					
#	*	*	*	7	13
Rate/100 Live Births	1.7	1.1	0.6	3.9	7.2
All Others					
#	*	*	8	*	22
Rate/100 Live Births	2.2	0.8	2.2	0.8	6.1
TOTAL					
#	50	20	23	38	131
Rate/100 Live Births	2.8	1.1	1.3	2.1	7.3

* Cell size suppressed because one or more cells within the row or column is less than five.

Source: Office of Health Status Monitoring, Hawai'i State Department of Health

Resident Infant Deaths by Ethnicity of Infant and Age of Infant: State of Hawai'i, 2004

Ethnicity of Infant	Age of Infant				TOTAL
	1 Day <	1-6 Days	7-27 Days	28 Days to 11 Months	
Caucasian					
#	7	6	*	*	19
Rate/100 Live Births	2.3	2	1.3	0.7	6.2
Hawaiian / Part Hawaiian					
#	20	*	*	12	39
Rate/100 Live Births	3	0.6	0.4	1.8	5.8
Filipino					
#	*	0	*	*	14
Rate/100 Live Births	2.1	0.0	1.4	1.4	4.8
Japanese					
#	*	*	*	*	10
Rate/100 Live Births	0.6	2.3	1.7	1.1	5.7
All Others					
#	9	*	0	*	15
Rate/100 Live Births	2.4	0.5	0.0	1.1	4.0
TOTAL					
#	43	16	14	24	97
Rate/100 Live Births	2.4	0.9	0.8	1.3	5.3

* Cell size suppressed because one or more cells within the row or column is less than five.

Source: Office of Health Status Monitoring, Hawai'i State Department of Health

Vital Indicators of Maternal and Child Health Ranked by Ethnicity of Mother Residents: State of Hawai'i, 2003

Vital Indicators	By Ethnicity of Mother					
	Caucasian	Hawaiian / Part Hawaiian	Chinese	Filipino	Japanese	TOTAL
Resident Standard Fetal Death Ratio (Fetal Deaths / Live Births) X 1000	41.5	35.9	52.6	46.7	59.5	47.7
Resident Abortion Ratio (Abortions / Live Births) X 1000	230.6	143.6	187.5	190.5	176.7	198.2
# Abortions to Unmarried Patients	742	605	84	529	313	2,800
# Abortions to teens 10-17 Years Old	51	98	8	88	42	353
# Pregnancies	5,180	5,749	754	4,319	2,722	22,507
# Pregnancies Among Teens 10-17 Years Old	75	353	13	205	63	843
# Live Births to Teens 10-17 Years Old	23	242	5	113	19	466
# Live Births to Mothers 45 and Older	<5	12	6	<5	<5	31
% Live Births to Unmarried Mothers (Non-Marital Live Births / Live Births) X 100	16.1	55.1	11.8	34.7	17.7	33.5
% Live Births w/ Late or No Prenatal Care (Live Births w/ Late or No Prenatal Care / Live Births) X 100	11.6	22.0	7.7	16.4	10.1	17.0
% Single Live Births w/ Low Birth Weight (Single Live Births LT 2500 Grams / Single Live Births) X 100	4.8	7.4	6.7	9.6	8.0	7.2
% Teen Live Births 10-17 With Low Birth Weight (Teen Live Births 10-17 LT 2500 Grams / Teen Live Births 10-17) X 100	17.4	12.4	-	15.0	15.8	13.3
Neonatal Mortality Rate (Infant Deaths <28 Day / Live Births) X 1000	3.2	6.2	-	6.3	3.2	5.1

Source: Office of Health Status Monitoring, Hawai'i State Department of Health

Vital Indicators of Maternal and Child Health Ranked by Ethnicity of Mother Residents: State of Hawai'i, 2004

Vital Indicators	By Ethnicity of Mother					
	Caucasian	Hawaiian / Part Hawaiian	Chinese	Filipino	Japanese	TOTAL
Resident Standard Fetal Death Ratio (Fetal Deaths / Live Births) X 1000	37.5	32.8	68.8	41.5	55.8	48.5
Resident Abortion Ratio (Abortions / Live Births) X 1000	239.3	145.4	161.4	176.5	144.6	188.7
# Abortions to Unmarried Patients	783	620	78	463	275	2,769
# Abortions to teens 10-17 Years Old	67	80	9	62	45	328
# Pregnancies	5,144	5,925	823	4,169	2,582	22,565
# Pregnancies Among Teens 10-17 Years Old	93	344	13	169	65	807
# Live Births to Teens 10-17 Years Old	25	249	*	103	*	457
# Live Births to Mothers 45 and Older	17	*	*	7	10	39
% Live Births to Unmarried Mothers (Non-Marital Live Births / Live Births) X 100	18.1	56.8	12.3	34.0	18.1	34.5
% Live Births w/ Late or No Prenatal Care (Live Births w/ Late or No Prenatal Care / Live Births) X 100	13.2	22.7	9.3	16.1	10.4	17.5
% Single Live Births w/ Low Birth Weight (Single Live Births LT 2500 Grams / Single Live Births) X 100	4.4	6.4	7.8	8.5	6.0	6.3
% Teen Live Births 10-17 With Low Birth Weight (Teen Live Births 10-17 LT 2500 Grams / Teen Live Births 10-17) X 100	-	10.0	-	12.6	-	9.4
Neonatal Mortality Rate (Infant Deaths <28 Day / Live Births) X 1000	4.0	4.4	6.0	3.5	3.3	4.0

* Cell size suppressed because one or more cells within the row or column is less than five.

Source: Office of Health Status Monitoring, Hawai'i State Department of Health

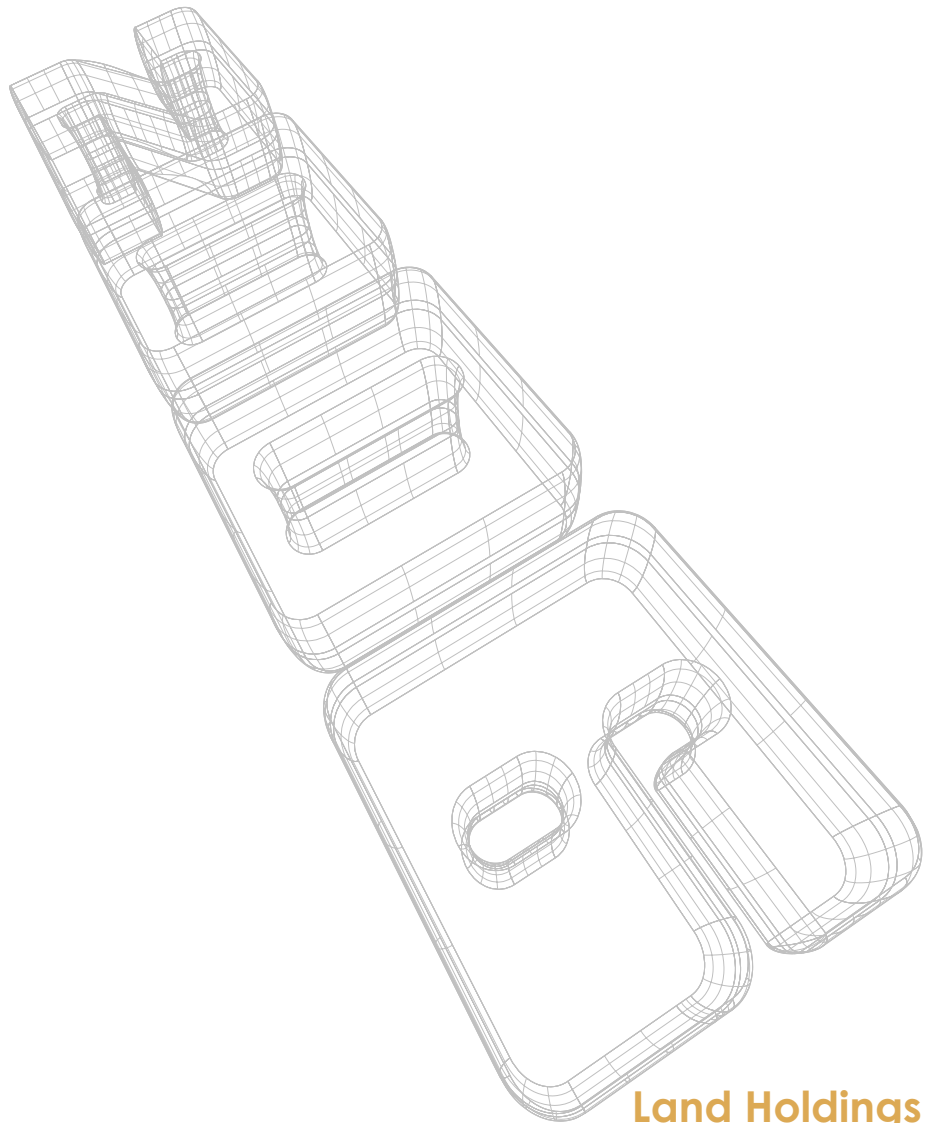

Land Holdings

LAND

The total land area in the State of Hawai'i is approximately 4,112,388 acres, spread out over eight major islands with Hawai'i Island accounting for about two-thirds of the total. Over the millennia, lava flow and other natural processes characteristic to the land masses were converted to grasslands and forests. Native Hawaiians traveling to the islands on traditional sailing vessels began the process of human development centuries ago.

Ever since Kamehameha unified the islands at the beginning of the 19th Century, land and the control of land have been central to political, economic and social power in Hawai'i. During this time, land use and ownership in Hawai'i have changed dramatically. Prior to the 1848 Mahele, Native Hawaiians were sole custodians of the land. By the close of the 20th Century, Hawai'i's primary cash crop of sugar cane has been marginalized while residential, industrial and recreational land uses have increased under the jurisdiction of local, state, and federal government, and private landowners. From a geographical perspective, changes to the land are apparent in previously cultivated land covers. Natural processes such as the conversion of old lava flows to grasslands; and human development mostly in the form of resorts and hotels along the coasts.

Unlike most other states, the state of Hawai'i retains some land use control. There are four statewide land use districts: conservation, agricultural, urban, and rural. Conservation and agricultural lands constitute 95% of Hawai'i's land use districts. Re-designation of land use districts is delegated to the State Land Use Commission. Counties control land use in the rural and urban districts.

The current land tenure in the State of Hawai'i is highly concentrated among few owners. The government (federal, state, county) owns approximately 38% of the land, while six private landowners own 36% of the remaining 62% of the total land in the State. The Department of Hawaiian Homelands, the state office that administers land set aside for the use and benefit of native Hawaiians, administers 201,660 acres of homestead lands. The bulk of these lands are located on the islands of Hawai'i (58%) and Maui (15%). Of the 201,660 acres, only 42% of the homestead lands are currently in use.

Estimated Acreage of Land Use Districts, By Islands: December 31, 2003

Island	Total Area 1/	Classification by State Land Use Commission 2/			
		Urban	Conservation	Agricultural	Rural
State total	4,112,388	196,215	1,973,636	1,932,429	10,108
Hawai'i	2,573,400	53,722	1,304,347	1,214,527	804
Maui 3/	465,800	21,409	194,836	245,777	3,778
Kaho'olawe	28,800	-	28,800	-	-
Lāna'i	90,500	3,257	38,197	46,639	2,407
Moloka'i	165,800	2,539	49,768	111,627	1,866
O'ahu 3/	386,188	100,730	156,619	128,839	-
Kaua'i	353,900	14,558	198,769	139,320	1,253
Ni'ihau	45,700	-	-	45,700	-
Ka'ula and Lehua	400	-	400	-	-
Other islands 4/	1,900	-	1,900	-	-

1/ These totals differ somewhat from the official figures based on measurements by the Geography Division for the U.S. Bureau of the Census, cited in Section 5.

2/ For definitions, see Hawaii Revised Statutes, Section 205-2.

3/ May be revised, pending updates of County records.

4/ The Northwestern Hawaiian Islands, from Nihoa to Kure Atoll, excluding Midway.

Source: Hawaii State Department of Business, Economic Development & Tourism, Land Use Commission, records.

Land Owned in Fee Simple by Selected Large Landowners: 2000 to 2003

Landowner	2000	2001	2002	2003
Eight large landowners	976,393	971,977	953,907	822,606
Percent of total land area ¹	23.8	23.6	23.2	20.0
Alexander and Baldwin, Inc.	90,800	90,600	90,600	90,000
C. Brewer and Company, Ltd.	75,744	71,188	55,377	44,210
Castle & Cooke, Inc.	95,200	94,973	94,760	94,737
Dole Food Company, Inc.	28,515	28,512	28,507	28,472
James Campbell Estate	62,400	62,200	62,200	59,645
Kamehameha Schools	366,042	366,458	365,794	365,760
Parker Ranch	136,332	136,686	135,312	134,446
Samuel M. Damon Estate	121,360	121,360	121,357	5,336 ²

¹ Based on an area of 4,110,966 acres.

² A significant amount of land was conveyed to various entities in 2003.

Source: Hawaii State Department of Business, Economic Development & Tourism, annual survey of major landowners.

Queen Lili'uokalani Trust Land Holdings - 2004

Island	Acres	% of Total Land in Hawai'i
O'ahu	83	1%
Hawai'i	6,284	99%
TOTAL	6,367	100%

Source: Queen Lili'uokalani Trust

Queen Lili'uokalani Trust - Usage of Land Holdings

Island / Use	Acres	% of Total Land in Hawai'i
O'ahu		
Commercial	2	2%
Agricultural	59	71%
Hotel	9	11%
Residential	13	16%
TOTAL	83	100%
Hawai'i		
Commercial	416	7%
Agricultural	1,425	23%
Industrial	68	1%
Conservation / Open	4,346	69%
Residential	29	0%
TOTAL	6,284	100%
Statewide		
Commercial	418	6.6%
Agricultural	1,484	23.3%
Hotel	9	0.1%
Industrial	68	1.1%
Conservation / Open	4,346	68.3%
Residential	42	0.7%
TOTAL	6,367	100.1%

Source: Queen Lili'uokalani Trust

Lunalilo Trust - Land Holdings

Island	Useage	% of Total Land in Hawai'i	Acres
O'ahu	Lunalilo Homes	100%	5
TOTAL		100%	5

Source: Lunalilo Trust

Kamehameha Schools - Land Holdings

Useage	Acres	Percent Dedicated per Use
Total KS-owned lands Statewide	365,000	
Agricultural		47.12
Conservation		47.67
Commerical Assets		4.3
Residential Assets		< 1.00

Source: Kamehameha Schools

Department of Hawaiian Homelands Land Use Summary by Island in Acres

Acreage Use	Total State	Hawaii	Maui	Molokai	Oahu	Kauai	Lanai
Homesteads	42,112	27,288	2,022	11,005	968	815	14
General Leases	51,540	46,159	512	1,767	50	3,052	-
Licenses	36,698	16,070	7,088	304	201	13,035	-
Others	71,310	27,446	22,066	12,310	5,796	3,656	36
TOTAL	201,660	116,963	31,688	25,386	7,015	20,558	50

Department of Hawaiian Homelands Income Summary by Use and Island

Land Use	Total State	Hawaii	Maui	Molokai	Oahu	Kauai	Lanai
Industrial Leases	\$3,394,905	\$1,646,184	\$-	\$-	\$1,748,721	\$-	\$-
Commerical Leases	\$1,821,944	\$1,446,944	\$-	\$-	\$375,000	\$-	\$-
Pasture/Agriculture Leases	\$291,388	\$206,323	\$49,400	\$9,690	\$5,967	\$20,008	\$-
Other Leases	\$431,220	\$89,655	\$1,530	\$175,240	\$164,315	\$480	\$-
Revocable Permits	\$352,184	\$57,667	\$24,048	\$17,325	\$173,144	\$80,000	\$-
Right of Entry Permits	\$12,200	\$-	\$-	\$12,200	\$-	\$-	\$-
Licenses	\$626,137	\$303,502	\$5,162	\$31,387	\$254,628	\$31,458	\$-
TOTAL	\$6,929,978	\$3,750,275	\$80,140	\$245,842	\$2,721,775	\$131,946	\$0.00

Source: Department of Hawaiian Homelands Annual Report

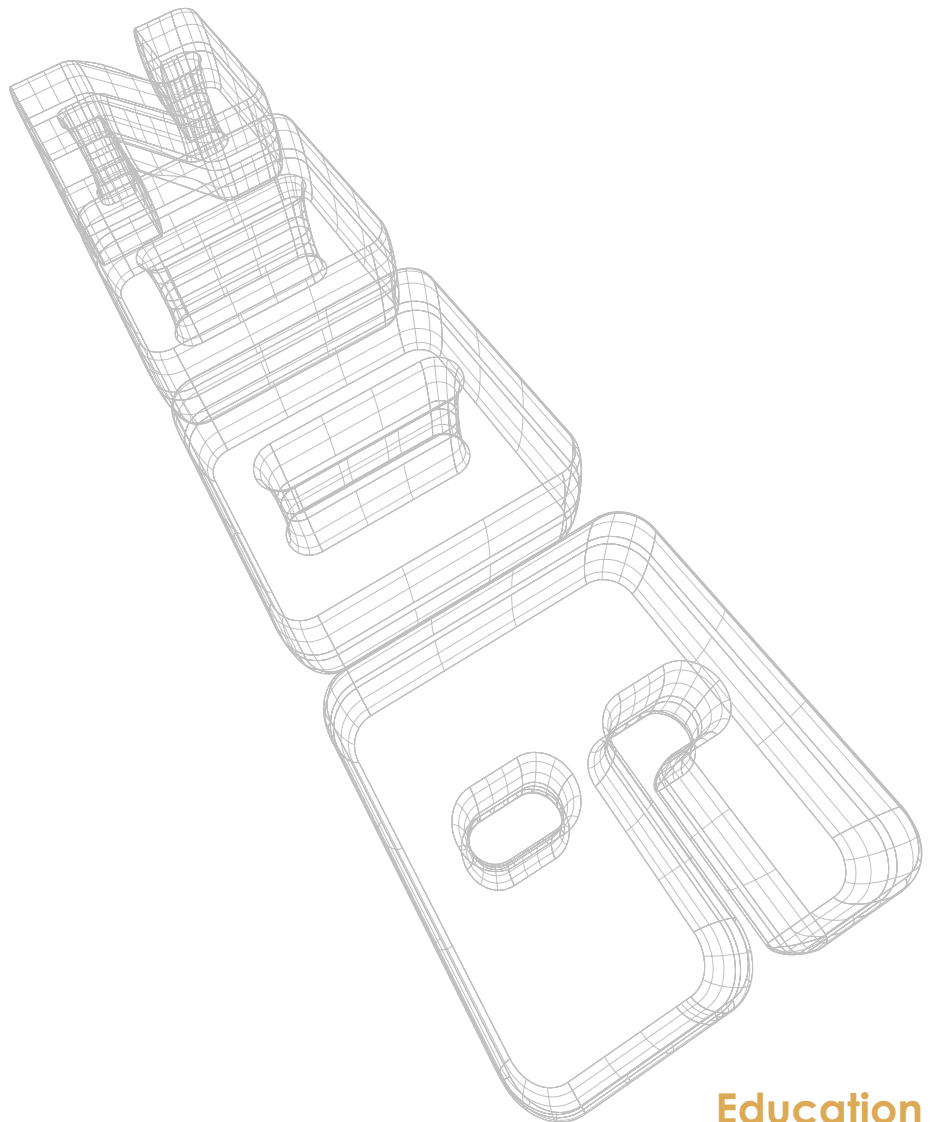

Education

EDUCATION

Education is among the most important issues facing Hawaiians today. Many Hawaiians see attaining appropriate educational opportunities as the key to individual self-sufficiency and collective self-determination. Unfortunately, too many Hawaiians have not had adequate access to quality educational experiences, nor have they been able to obtain the types of education that will allow them to break out of the cycles of poverty, dependence and low self-esteem.

Recently, Hawaiian educators, parents and communities have begun to seriously address the wide range of educational problems facing Hawaiians. Joined by Hawaiian language and culture specialists, they have established programs that enrich haumana and their 'ohana by providing strong preparation for academic achievement. Culturally relevant, high quality educational initiatives draw on the resources of data-based research, as well as the wisdom of Hawai'i's kūpuna, and collectively share curricula, materials and assessment tools. Such programs often function as the kahua for knowledge about how to effectively sustain and enhance "best practices" in Hawaiian education.

Members of the Native Hawaiian educational community, and the students and 'ohana they serve, work tirelessly to encourage life-long learning, increase cultural knowledge and Hawaiians' sense of identity, while mitigating the dire economic circumstances of Hawaiians who have been poorly prepared by the mainstream educational system to become productive citizens and active members of a reinvigorated Hawaiian nation.

Native Hawaiian Educational Attainment: Statewide, 2000

	Number	Percent
Native Hawaiian population 25 years and older	121,375	100.0
Less than 9th grade	4,155	3.4
9th - 12th grade, no diploma	14,035	11.6
High school graduate (includes equivalency)	52,400	43.2
Some college, no degree	27,125	22.3
Associate's degree	8,350	6.9
Bachelor's degree	11,410	9.4
Graduate or Professional degree	3,905	3.2
High school graduate or higher	103,185	85.0
Bachelor's degree or higher	15,315	12.6

Native Hawaiian Educational Attainment: Island of Hawai'i, 2000

	Number	Percent
Native Hawaiian population 25 years and older	20,615	100.0
Less than 9th grade	724	3.5
9th - 12th grade, no diploma	2,405	11.7
High school graduate (includes equivalency)	9,295	45.1
Some college, no degree	4,555	22.1
Associate's degree	1,570	7.6
Bachelor's degree	1,605	7.8
Graduate or Professional degree	468	2.3
High school graduate or higher	17,490	84.8
Bachelor's degree or higher	2,060	10.0

Source: Kamehameha Schools, Aloha Counts: Census 2000 Special Tabulations for Native Hawaiians.

Native Hawaiian Educational Attainment: Island of Kaua'i, 2000

	Number	Percent
Native Hawaiian population 25 years and older	6,245	100.0
Less than 9th grade	230	3.7
9th - 12th grade, no diploma	660	10.6
High school graduate (includes equivalency)	2,795	44.8
Some college, no degree	1,525	24.4
Associate's degree	470	7.5
Bachelor's degree	420	6.7
Graduate or Professional degree	160	2.6
High school graduate or higher	5,360	85.8
Bachelor's degree or higher	580	9.3

Native Hawaiian Educational Attainment: Island of Lāna'i, 2000

	Number	Percent
Native Hawaiian population 25 years and older	350	100.0
Less than 9th grade	20	5.7
9th - 12th grade, no diploma	50	14.3
High school graduate (includes equivalency)	160	45.7
Some college, no degree	80	22.9
Associate's degree	20	5.7
Bachelor's degree	20	5.7
Graduate or Professional degree	-	0.0
High school graduate or higher	280	80.0
Bachelor's degree or higher	20	5.7

Source: Kamehameha Schools, Aloha Counts: Census 2000 Special Tabulations for Native Hawaiians.

Native Hawaiian Educational Attainment: Island of Maui, 2000

	Number	Percent
Native Hawaiian population 25 years and older	12,375	100.0
Less than 9th grade	505	4.1
9th - 12th grade, no diploma	1,645	13.3
High school graduate (includes equivalency)	5,580	45.1
Some college, no degree	2,805	22.7
Associate's degree	730	5.9
Bachelor's degree	880	7.1
Graduate or Professional degree	235	1.9
High school graduate or higher	10,225	82.6
Bachelor's degree or higher	1,115	9.0

Native Hawaiian Educational Attainment: Island of Moloka'i, 2000

	Number	Percent
Native Hawaiian population 25 years and older	2,120	100.0
Less than 9th grade	110	5.2
9th - 12th grade, no diploma	320	15.1
High school graduate (includes equivalency)	1,050	49.5
Some college, no degree	430	20.3
Associate's degree	105	5.0
Bachelor's degree	70	3.3
Graduate or Professional degree	35	1.7
High school graduate or higher	1,690	79.7
Bachelor's degree or higher	105	5.0

Source: Kamehameha Schools, Aloha Counts: Census 2000 Special Tabulations for Native Hawaiians.

Native Hawaiian Educational Attainment: Island of O'ahu, 2000

	Number	Percent
Native Hawaiian population 25 years and older	79,505	100.0
Less than 9th grade	2,564	3.2
9th - 12th grade, no diploma	8,900	11.2
High school graduate (includes equivalency)	33,445	42.1
Some college, no degree	17,710	22.3
Associate's degree	5,455	6.9
Bachelor's degree	8,425	10.6
Graduate or Professional degree	3,015	3.8
High school graduate or higher	68,035	85.6
Bachelor's degree or higher	11,430	14.4

Source: Kamehameha Schools, Aloha Counts: Census 2000 Special Tabulations for Native Hawaiians.

Educational Attainment of Individuals 18 years and Older: Hawai'i Health Survey, 2003

Educational Attainment	County									
	Honolulu		Hawai'i		Kaua'i		Maui		Total	
	Number	Percent	Number	Percent	Number	Percent	Number	Percent	Number	Percent
Statewide TOTAL	653,861	71.6%	115,293	12.6%	44,554	4.9%	100,041	10.9%	913,749	100%
No school - 8th grade	16,082	14.8%	2,673	9.9%	2,180	27.0%	3,502	19.7%	24,437	15.2%
Grades 9 - 11	22,105	20.4%	6,688	24.8%	1,846	22.9%	3,603	20.3%	34,242	21.3%
Grade 12 / GED	218,259	201.5%	42,947	159.4%	16,211	201.0%	37,028	208.3%	314,444	195.2%
College 1 - 3 years	153,162	141.4%	29,481	109.5%	11,196	138.8%	26,121	146.9%	219,961	136.5%
College 4+ years	230,456	212.7%	31,527	117.0%	12,377	153.4%	27,579	155.1%	301,938	187.4%
Unknown / Refused / Missing / <18	13,796	12.7%	1,977	7.3%	746	9.2%	2,207	12.4%	18,726	11.6%
Native Hawaiian TOTAL ...	108,335	67.2%	26,935	16.7%	8,066	5.0%	17,779	11.0%	161,115	17.6%
No school - 8th grade	*	*	348	1.3%	*	*	344	1.9%	2,841	1.8%
Grades 9 - 11	4,018	3.7%	1,836	6.8%	382	4.7%	890	5.0%	7,127	4.4%
Grade 12 / GED	51,821	47.8%	13,837	51.4%	4,399	54.5%	9,582	53.9%	79,639	49.4%
College 1 - 3 years	27,579	25.5%	6,793	25.2%	2,021	25.1%	4,982	28.0%	41,374	25.7%
College 4+ years	21,906	20.2%	3,635	13.5%	1,010	12.5%	1,792	10.1%	28,342	17.6%
Unknown / Refused / Missing / <18	*	*	486	1.8%	*	*	189	1.1%	1,791	1.1%

Source: Office of Health Status Monitoring, Hawaii State Department of Health

Note:

* Sample □

holds without telephones are not represented, see HHS Procedure Manual 2003

* Row and / or column totals may not sum to totals listed due to rounding

* If sample numerator <50 or sample denominator <50, data are not reliable

* Sample size 10,952 people

Kamehameha Schools' Official Enrollment: School Year 2003 - 2004

	Campus			
	Kapalama	Hawai'i	Maui	Total
Elementary	752	256	257	1,265
Grade 1	80	40	40	160
Grade 2	80	40	40	160
Grade 3	80	40	41	161
Grade 4	144	48	48	240
Grade 5	144	48	48	240
Grade 6	144	n/a	n/a	144
Middle	640	287	285	1,212
Grade 6	n/a	96	97	193
Grade 7	324	96	94	514
Grade 8	316	95	94	505
High	1,805	286	286	2,377
Grade 9	455	143	144	742
Grade 10	450	143	142	735
Grade 11	453	n/a	n/a	453
Grade 12	447	n/a	n/a	447
TOTAL	3,197	829	828	4,854

Source: Kamehameha Schools, KS Official Enrollment: School Year 2003-04, PASE Report 03-04:18.

Please note that all Hawai'i Department of Education statistics include the following charter schools:

1. Connections New Century Public Charter School
2. Education Laboratory: A Hawai'i New Century Public Charter School
3. Hakipu'u Learning Center: A Hawai'i Public Charter School
4. Hālau Kū Māna: A New Century Public Charter School
5. Hālau Lōkahi: A New Century Public Charter School
6. Hawai'i Academy of Arts and Science Public Charter School
7. Innovations Public Charter School
8. Ka 'Umeke Ka'eo Public Charter School
9. Ka Waihona 'o ka Na'auao New Century Public Charter School
10. Kanu o ka 'Āina New Century Public Charter School
11. Kanuikapono Learning Center Public Charter School
12. Ke Ana La'ahana Public Charter School
13. Ke Kula 'o Nawahiokalani'ōpu'u Iki Laboratory Public Charter School
14. Ke Kula Ni'ihau o Kekaha Learning Center: A Laboratory Public Charter School
15. Ke Kula 'o Samuel M. Kamakau Laboratory Public Charter School
16. Kihei Public Charter High School
17. Kua o ka Lā Public Charter School
18. Kualapu'u Elementary New Century Public Conversion Charter School
19. Kula Aupuni Ni'ihau A Kehlelani Aloha (KANAKA) New Century Public Charter School
20. Lanikai Elementary Public Charter School
21. Myron B. Thompson Academy: A New Century Public Charter School
22. Volcano School of Arts and Sciences: A Community Public Charter School
23. Voyager: A Public Charter School
24. Wai'alae Elementary Public Charter School
25. Waimea Middle Public Conversion Charter School
26. Waters of Life New Century Public Charter School
27. West Hawai'i Explorations Academy Public Charter School

Hawaiian Students in Hawai'i's Department of Education (DOE) by District: 2002 -2003

DOE District	Number	Percent	
Honolulu	5,378	11	
Central	4,322	9	
Leeward	11,073	23	
Windward	7,147	15	
Hawai'i	10,028	21	
Maui	6,531	14	
	Island of Maui	5,270	11
	Moloka'i	1,115	2
	Lāna'i	146	1
Kaua'i	3,242	7	
STATE TOTAL	47,721	100	

Source: Kamehameha Schools, Hawaiian Enrollment in the DOE, PASE Report 03-04:01.

Hawaiian Students in Hawai'i Public Schools: 2002 - 2003

	Hawaiian		Others		TOTAL	
	Number	Percent	Number	Percent	Number	Percent
Pre-Kindergarten	289	25.9	827	74.1	1,116	100
Kindergarten	3,531	26.1	10,016	73.9	13,547	100
Grade 1	3,834	26.6	10,576	73.4	14,410	100
Grade 2	3,685	25.8	10,587	74.2	14,272	100
Grade 3	3,803	26.0	10,845	74.0	14,648	100
Grade 4	3,801	26.1	10,788	73.9	14,589	100
Grade 5	3,814	25.8	10,963	74.2	14,777	100
Grade 6	4,066	27.1	10,930	72.9	14,996	100
Grade 7	4,024	27.6	10,556	72.4	14,580	100
Grade 8	3,724	27.0	10,071	73.0	13,795	100
Grade 9	4,347	27.1	11,714	72.9	16,061	100
Grade 10	3,344	24.5	10,285	75.5	13,629	100
Grade 11	3,044	24.2	9,556	75.8	12,600	100
Grade 12	2,392	22.9	8,058	77.1	10,450	100
Special Education	23	29.1	56	70.9	79	100
TOTAL	47,721	26.0	135,828	74.0	183,549	100

Source: Kamehameha Schools, *Hawaiian Enrollment in the DOE, PASE Report 03-04:01*.

Statewide DOE Student Enrollment: 2003-2004

	Hawaiian	Others
2003-2004		
Number	47,734	134,010
Percentage	26	74
2002-2003		
Number	47,721	135,828
Percentage	26	74

Source: Kamehameha Schools, *Snapshot of Hawaiians in the DOE, PASE Report 04-05:10*.

Hawaiian Students in Hawai'i Public Schools - Honolulu (O'ahu) District: 2002 - 2003

	Hawaiian		Others		TOTAL	
	Number	Percent	Number	Percent	Number	Percent
Pre-Kindergarten	34	19.5	140	80.5	174	100
Kindergarten	381	15.1	2,149	84.9	2,530	100
Grade 1	448	16.2	2,319	83.8	2,767	100
Grade 2	430	15.4	2,366	84.6	2,796	100
Grade 3	457	15.8	2,435	84.2	2,892	100
Grade 4	442	15.6	2,398	84.4	2,840	100
Grade 5	400	14.7	2,318	85.3	2,718	100
Grade 6	448	15.9	2,377	84.1	2,825	100
Grade 7	466	18.3	2,074	81.7	2,540	100
Grade 8	419	16.5	2,121	83.5	2,540	100
Grade 9	522	17.2	2,505	82.8	3,027	100
Grade 10	373	15.0	2,110	85.0	2,483	100
Grade 11	315	14.3	1,888	85.7	2,203	100
Grade 12	239	12.6	1,655	87.4	1,894	100
Special Education	4	15.4	22	84.6	26	100
TOTAL	5,378	15.7	28,877	84.3	34,255	100

Source: Kamehameha Schools, Hawaiian Enrollment in the DOE, PASE Report 03-04:01.

Honolulu DOE Student Enrollment: 2003-2004

	Hawaiian	Others
2003-2004		
Number	5,357	28,710
Percentage	16	84
2002-2003		
Number	5,378	28,877
Percentage	16	84

Source: Kamehameha Schools, Snapshot of Hawaiians in the DOE, PASE Report 04-05:10.

Hawaiian Students in Hawai'i Public Schools - Central O'ahu District: 2002 - 2003

	Hawaiian		Others		TOTAL	
	Number	Percent	Number	Percent	Number	Percent
Pre-Kindergarten	25	8.7	261	91.3	286	100
Kindergarten	299	11.0	2,431	89.0	2,730	100
Grade 1	348	12.1	2,526	87.9	2,874	100
Grade 2	331	11.6	2,518	88.4	2,849	100
Grade 3	363	12.8	2,470	87.2	2,833	100
Grade 4	361	13.2	2,366	86.8	2,727	100
Grade 5	334	12.1	2,426	87.9	2,760	100
Grade 6	348	12.9	2,348	87.1	2,696	100
Grade 7	347	13.4	2,236	86.6	2,583	100
Grade 8	361	14.3	2,172	85.7	2,533	100
Grade 9	397	15.0	2,253	85.0	2,650	100
Grade 10	295	12.5	2,058	87.5	2,353	100
Grade 11	287	13.0	1,925	87.0	2,212	100
Grade 12	226	12.2	1,628	87.8	1,854	100
TOTAL	4,322	12.7	29,618	87.3	33,940	100

Source: Kamehameha Schools, Hawaiian Enrollment in the DOE, PASE Report 03-04:01.

Central DOE Student Enrollment: 2003-2004

	Hawaiian	Others
2003-2004		
Number	4,315	28,953
Percentage	16	84
2002-2003		
Number	4,322	29,618
Percentage	13	87

Source: Kamehameha Schools, Snapshot of Hawaiians in the DOE, PASE Report 04-05:10.

Hawaiian Students in Hawai'i Public Schools - Leeward O'ahu District: 2002 - 2003

	Hawaiian		Others		TOTAL	
	Number	Percent	Number	Percent	Number	Percent
Pre-Kindergarten	71	30.3	163	69.7	234	100
Kindergarten	829	29.6	1,970	70.4	2,799	100
Grade 1	915	29.7	2,163	70.3	3,078	100
Grade 2	882	29.1	2,148	70.9	3,030	100
Grade 3	904	28.6	2,258	71.4	3,162	100
Grade 4	880	28.5	2,206	71.5	3,086	100
Grade 5	932	29.2	2,262	70.8	3,194	100
Grade 6	965	29.8	2,276	70.2	3,241	100
Grade 7	1,007	30.1	2,344	69.9	3,351	100
Grade 8	882	30.1	2,047	69.9	2,929	100
Grade 9	1,028	28.9	2,523	71.1	3,551	100
Grade 10	705	26.4	1,968	73.6	2,673	100
Grade 11	611	25.6	1,773	74.4	2,384	100
Grade 12	457	25.1	1,362	74.9	1,819	100
Special Education	5	31.3	11	68.8	16	100
TOTAL	11,073	28.7	27,474	71.3	38,547	100

Source: Kamehameha Schools, Hawaiian Enrollment in the DOE, PASE Report 03-04:01.

Leeward DOE Student Enrollment: 2003-2004

	Hawaiian	Others
2003-2004		
Number	11,327	27,759
Percentage	29	71
2002-2003		
Number	11,073	27,474
Percentage	29	71

Source: Kamehameha Schools, Snapshot of Hawaiians in the DOE, PASE Report 04-05:10.

Hawaiian Students in Hawai'i Public Schools - Windward O'ahu District : 2002 - 2003

	Hawaiian		Others		TOTAL	
	Number	Percent	Number	Percent	Number	Percent
Pre-Kindergarten	43	34.4	82	65.6	125	100
Kindergarten	539	38.7	853	61.3	1,392	100
Grade 1	584	39.2	905	60.8	1,489	100
Grade 2	547	38.0	892	62.0	1,439	100
Grade 3	586	39.5	897	60.5	1,483	100
Grade 4	590	39.7	895	60.3	1,485	100
Grade 5	555	37.0	943	63.0	1,498	100
Grade 6	615	40.0	921	60.0	1,536	100
Grade 7	609	42.2	833	57.8	1,442	100
Grade 8	507	39.7	770	60.3	1,277	100
Grade 9	635	39.0	994	61.0	1,629	100
Grade 10	489	36.4	853	63.6	1,342	100
Grade 11	471	35.8	843	64.2	1,314	100
Grade 12	370	34.5	703	65.5	1,073	100
Special Education	7	43.8	9	56.3	16	100
TOTAL	7,147	38.5	11,393	61.5	18,540	100

Source: Kamehameha Schools, Hawaiian Enrollment in the DOE, PASE Report 03-04:01.

Windward DOE Student Enrollment: 2003-2004

	Hawaiian	Others
2003-2004		
Number	6,935	10,746
Percentage	39	61
2002-2003		
Number	7,147	11,393
Percentage	39	61

Source: Kamehameha Schools, Snapshot of Hawaiians in the DOE, PASE Report 04-05:10.

Hawaiian Students in Hawai'i Public Schools - Kaua'i District: 2002 - 2003

	Hawaiian		Others		TOTAL	
	Number	Percent	Number	Percent	Number	Percent
Pre-Kindergarten	17	34.0	33	66.0	50	100
Kindergarten	236	34.2	455	65.8	691	100
Grade 1	235	32.8	482	67.2	717	100
Grade 2	250	35.3	458	64.7	708	100
Grade 3	270	33.5	536	66.5	806	100
Grade 4	274	33.9	537	66.2	811	100
Grade 5	271	33.8	531	66.2	802	100
Grade 6	305	34.0	593	66.0	898	100
Grade 7	238	28.6	593	71.4	831	100
Grade 8	249	30.4	570	69.6	819	100
Grade 9	289	29.4	695	70.6	984	100
Grade 10	201	23.4	657	76.6	858	100
Grade 11	245	30.0	571	70.0	816	100
Grade 12	160	24.7	489	75.3	649	100
Special Education	2	25.0	6	75.0	8	100
TOTAL	3,242	31.0	7,206	69.0	10,448	100

Source: Kamehameha Schools, Hawaiian Enrollment in the DOE, PASE Report 03-04:01.

Kaua'i DOE Student Enrollment: 2003-2004

	Hawaiian	Others
2003-2004		
Number	3,276	6,876
Percentage	32	68
2002-2003		
Number	3,242	7,206
Percentage	31	69

Source: Kamehameha Schools, Snapshot of Hawaiians in the DOE, PASE Report 04-05:10.

Hawaiian Students in Hawai'i Public Schools - Maui District: 2002 - 2003

	Hawaiian		Others		TOTAL	
	Number	Percent	Number	Percent	Number	Percent
Pre-Kindergarten	32	36.0	57	64.0	89	100
Kindergarten	525	32.2	1,106	67.8	1,631	100
Grade 1	536	33.0	1,087	67.0	1,623	100
Grade 2	502	31.3	1,104	68.7	1,606	100
Grade 3	469	29.4	1,126	70.6	1,595	100
Grade 4	472	28.2	1,201	71.8	1,673	100
Grade 5	487	29.3	1,173	70.7	1,660	100
Grade 6	517	31.3	1,137	68.7	1,654	100
Grade 7	544	31.7	1,174	68.3	1,718	100
Grade 8	533	31.7	1,151	68.3	1,684	100
Grade 9	615	31.9	1,311	68.1	1,926	100
Grade 10	502	28.0	1,292	72.0	1,794	100
Grade 11	446	27.3	1,185	72.7	1,631	100
Grade 12	351	25.5	1,028	74.5	1,379	100
TOTAL	6,531	30.1	15,132	69.9	21,663	100

Source: Kamehameha Schools, Hawaiian Enrollment in the DOE, PASE Report 03-04:01.

Maui DOE Student Enrollment: 2003-2004

	Hawaiian	Others
2003-2004		
Number	5,092	14,137
Percentage	26	74
2002-2003		
Number	5,157	14,185
Percentage	27	73

Source: Kamehameha Schools, Snapshot of Hawaiians in the DOE, PASE Report 04-05:10.

Hawaiian Students in Hawai'i Public Schools - Hawai'i District: 2002 - 2003

	Hawaiian		Others		TOTAL	
	Number	Percent	Number	Percent	Number	Percent
Pre-Kindergarten	67	42.4	91	57.6	158	100
Kindergarten	722	40.7	1,052	59.3	1,774	100
Grade 1	768	41.2	1,094	58.8	1,862	100
Grade 2	743	40.3	1,101	59.7	1,844	100
Grade 3	754	40.2	1,123	59.8	1,877	100
Grade 4	782	39.8	1,185	60.2	1,967	100
Grade 5	835	38.9	1,310	61.1	2,145	100
Grade 6	868	40.4	1,278	59.6	2,146	100
Grade 7	813	38.4	1,302	61.6	2,115	100
Grade 8	773	38.4	1,240	61.6	2,013	100
Grade 9	861	37.5	1,433	62.5	2,294	100
Grade 10	779	36.6	1,347	63.4	2,126	100
Grade 11	669	32.8	1,371	67.2	2,040	100
Grade 12	589	33.1	1,193	66.9	1,782	100
Special Education	5	38.5	8	61.5	13	100
TOTAL	10,028	38.3	16,128	61.7	26,156	100

Source: Kamehameha Schools, Hawaiian Enrollment in the DOE, PASE Report 03-04:01.

Hawai'i District DOE Student Enrollment: 2003-2004

	Hawaiian	Others
2003-2004		
Number	10,082	15,890
Percentage	39	61
2002-2003		
Number	10,028	16,128
Percentage	38	62

Source: Kamehameha Schools, Snapshot of Hawaiians in the DOE, PASE Report 04-05:10.

DOE Lunch Status Data by District: SY 2002 - 2003

DOE District	Lunch Status (by percent)					
	Free		Reduced Price		Regular Price	
	Hawaiian	Others	Hawaiian	Others	Hawaiian	Others
Honolulu	43	33	11	8	46	58
Central	41	18	10	12	49	70
Leeward	54	30	12	11	34	58
Windward	42	21	12	9	45	69
Hawai'i	52	34	13	10	35	56
East Hawai'i	61	38	10	10	28	52
West Hawai'i	39	27	16	11	45	62
Maui	40	21	14	9	46	70
Island of Maui	37	21	13	9	50	71
Moloka'i	59	40	13	14	28	46
Lāna'i	27	15	7	14	66	71
Kaua'i	42	22	12	10	46	68
STATE TOTAL	47	26	12	10	41	63

Source: Kamehameha Schools, Snapshot of Hawaiians in the DOE: PASE Report 04-05:10.

Statewide DOE Standardized Test Scores, School Year (SY) 2001-2002

	Grade 3		Grade 5		Grade 8		Grade 10	
	Hawaiian	Others	Hawaiian	Others	Hawaiian	Others	Hawaiian	Others
SAT-9 Math								
Below average	32	18	30	16	36	23	43	32
Average	50	49	50	46	54	54	50	51
Above Average	18	32	20	38	10	22	7	17
SAT-9 Reading								
Below average	30	18	39	23	35	23	51	39
Average	61	63	51	53	57	59	46	54
Above Average	9	18	10	23	8	18	3	7
HCPS-II Math Standards								
Below	32	19	33	18	34	20	28	17
Approaches	57	58	58	56	57	56	64	59
Meets	11	22	9	24	9	22	8	22
Exceeds	1	2	-	2	-	2	-	1
HCPS-II Reading Standards								
Below	14	7	13	7	13	8	12	8
Approaches	55	45	56	44	57	44	60	45
Meets	30	45	30	47	29	46	28	45
Exceeds	1	3	-	2	1	2	-	2

Source: Kamehameha Schools, Hawai'i Content and Performance Standards (HCPS) II, School Year 2001-02 and SAT-9 Performance of Hawaiian Students in the DOE, School Year 2001-02, PASE Reports: 03-04:02, 03-04:03, 03-04:04, 03-04:05, 03-04:20, 03-04:21, 03-04:22, 03-04:23.

* column percentages, unless otherwise noted

*Below Average = stanine score of 1 - 3 (normal distribution: 23%)

*Average = stanine score of 4 - 6 (normal distribution: 54%)

*Above Average = stanine score of 7 - 9 (normal distribution: 23%)

Note: Percentages in table may not sum to 100% due to rounding. Data not reported for cells with fewer than ten students.

Statewide DOE Standardized Test Scores, School Year (SY) 2002-2003

	Grade 3		Grade 5		Grade 8		Grade 10	
	Hawaiian	Others	Hawaiian	Others	Hawaiian	Others	Hawaiian	Others
SAT-9 Math								
Below average	25	15	32	20	34	23	43	30
Average	59	58	53	55	56	54	53	61
Above Average	16	27	15	25	10	24	4	8
SAT-9 Reading								
Below average	26	15	35	20	35	23	45	31
Average	61	59	55	56	55	53	53	62
Above Average	13	26	10	24	10	24	2	7
HCPS-II Math Standards								
Below	26	16	34	20	35	23	45	31
Approaches	59	56	56	57	55	55	69	65
Meets	13	25	9	22	6	19	7	19
Exceeds	1	3	-	2	-	1	-	1
HCPS-II Reading Standards								
Below	14	8	24	12	14	8	13	7
Approaches	55	45	49	41	61	48	61	49
Meets	30	45	27	45	24	43	26	43
Exceeds	-	1	-	1	-	1	-	1
Total number of test takers	3,570	10,653	3,729	10,810	3,572	9,930	2,828	9,355

Source: Kamehameha Schools, Snapshot of Hawaiians in the DOE: PASE Report 04-05:10.

*column percentages, unless otherwise noted

*Below average = stanine score of 1-3 (normal distribution: 23%)

*Average = stanine score of 4-6 (normal distribution: 54%)

*Above Average = stanine score of 7-9 (normal distribution: 23%)

Note: Percentages in table may not sum to 100% due to rounding. Data not reported for cells with fewer than ten students.

Honolulu District DOE Standardized Test Scores, School Year (SY) 2001-2002

	Grade 3		Grade 5		Grade 8		Grade 10	
	Hawaiian	Others	Hawaiian	Others	Hawaiian	Others	Hawaiian	Others
SAT-9 Math								
Below average	30	19	25	16	25	17	42	28
Average	49	49	50	40	58	50	54	50
Above Average	21	33	24	44	17	33	4	22
SAT-9 Reading								
Below average	28	18	33	24	28	20	53	40
Average	59	64	53	50	60	61	45	53
Above Average	13	18	13	26	12	19	2	7
HCPS-II Math Standards								
Below	29	20	29	16	26	15	25	14
Approaches	56	54	57	50	59	51	66	56
Meets	14	23	14	29	15	31	9	28
Exceeds	1	3	1	5	-	3	-	2
HCPS-II Reading Standards								
Below	14	8	12	7	6	5	13	6
Approaches	48	44	51	42	55	40	54	42
Meets	36	45	36	49	38	51	32	50
Exceeds	1	3	1	3	1	3	-	2

Source: Kamehameha Schools, Hawai'i Content and Performance Standards (HCPS) II, School Year 2001-02 and SAT-9 Performance of Hawaiian Students in the DOE, School Year 2001-02, PASE Reports: 03-04:02, 03-04:03, 03-04:04, 03-04:05, 03-04:20, 03-04:21, 03-04:22, 03-04:23.

* column percentages, unless otherwise noted

*Below Average = stanine score of 1 - 3 (normal distribution: 23%)

*Average = stanine score of 4 - 6 (normal distribution: 54%)

*Above Average = stanine score of 7 - 9 (normal distribution: 23%)

Note: Percentages in table may not sum to 100% due to rounding. Data not reported for cells with fewer than ten students.

Honolulu District DOE Standardized Test Scores, School Year (SY) 2002-2003

	Grade 3		Grade 5		Grade 8		Grade 10	
	Hawaiian	Others	Hawaiian	Others	Hawaiian	Others	Hawaiian	Others
SAT-9 Math								
Below average	20	14	26	22	31	24	36	31
Average	57	58	52	50	57	52	55	60
Above Average	23	28	21	28	12	23	9	9
SAT-9 Reading								
Below average	20	15	30	22	33	25	38	31
Average	61	59	57	52	53	52	58	61
Above Average	19	26	13	27	14	24	3	8
HCPS-II Math Standards								
Below	24	17	31	21	33	22	23	15
Approaches	56	50	57	49	59	53	66	56
Meets	18	29	12	26	8	24	11	27
Exceeds	2	4	-	3	-	1	-	2
HCPS-II Reading Standards								
Below	13	8	22	13	12	9	9	9
Approaches	51	43	45	38	58	44	60	45
Meets	36	47	32	46	30	45	30	45
Exceeds	1	2	-	2	-	1	1	1
Total number of test takers	420	2,389	397	2,285	422	2,093	308	1,900

Source: Kamehameha Schools, Snapshot of Hawaiians in the DOE: PASE Report 04-05:10.

*column percentages, unless otherwise noted

*Below average = stanine score of 1-3 (normal distribution: 23%)

*Average = stanine score of 4-6 (normal distribution: 54%)

*Above Average = stanine score of 7-9 (normal distribution: 23%)

Note: Percentages in table may not sum to 100% due to rounding. Data not reported for cells with fewer than ten students.

Central District DOE Standardized Test Scores, School Year (SY) 2001-2002

	Grade 3		Grade 5		Grade 8		Grade 10	
	Hawaiian	Others	Hawaiian	Others	Hawaiian	Others	Hawaiian	Others
SAT-9 Math								
Below average	22	14	26	13	40	23	39	32
Average	53	49	50	46	52	60	54	50
Above Average	25	37	25	42	8	17	7	18
SAT-9 Reading								
Below average	23	15	38	19	36	20	48	35
Average	64	65	48	55	57	61	49	58
Above Average	13	21	13	26	7	19	3	7
HCPS-II Math Standards								
Below	25	14	29	14	33	20	22	16
Approaches	58	60	58	56	59	62	67	60
Meets	16	23	12	27	8	17	11	23
Exceeds	1	2	-	3	-	1	-	1
HCPS-II Reading Standards								
Below	10	5	13	6	15	8	13	7
Approaches	54	44	56	42	57	44	59	46
Meets	35	49	30	51	28	47	27	45
Exceeds	1	3	-	2	-	1	-	2

Source: Kamehameha Schools, Hawai'i Content and Performance Standards (HCPS) II, School Year 2001-02 and SAT-9 Performance of Hawaiian Students in the DOE, School Year 2001-02, PASE Reports: 03-04:02, 03-04:03, 03-04:04, 03-04:05, 03-04:20, 03-04:21, 03-04:22, 03-04:23.

* column percentages, unless otherwise noted

*Below Average = stanine score of 1 - 3 (normal distribution: 23%)

*Average = stanine score of 4 - 6 (normal distribution: 54%)

*Above Average = stanine score of 7 - 9 (normal distribution: 23%)

Note: Percentages in table may not sum to 100% due to rounding. Data not reported for cells with fewer than ten students.

Central District DOE Standardized Test Scores, School Year (SY) 2002-2003

	Grade 3		Grade 5		Grade 8		Grade 10	
	Hawaiian	Others	Hawaiian	Others	Hawaiian	Others	Hawaiian	Others
SAT-9 Math								
Below average	20	13	25	15	27	17	44	25
Average	61	58	49	57	59	54	51	66
Above Average	19	28	26	28	14	29	4	9
SAT-9 Reading								
Below average	18	14	29	16	28	18	47	26
Average	63	58	55	58	60	54	52	66
Above Average	18	28	16	26	12	29	1	8
HCPS-II Math Standards								
Below	22	14	27	15	33	20	22	11
Approaches	63	58	58	57	59	56	69	68
Meets	15	26	14	26	7	23	8	20
Exceeds	-	2	1	2	-	1	-	1
HCPS-II Reading Standards								
Below	11	7	17	10	11	5	13	5
Approaches	53	44	46	40	57	45	57	46
Meets	36	47	37	49	31	48	29	47
Exceeds	-	1	1	2	-	1	-	1
Total number of test takers	347	2,407	319	2,373	346	2,143	253	1,933

Source: Kamehameha Schools, Snapshot of Hawaiians in the DOE: PASE Report 04-05:10.

*column percentages, unless otherwise noted

*Below average = stanine score of 1-3 (normal distribution: 23%)

*Average = stanine score of 4-6 (normal distribution: 54%)

*Above Average = stanine score of 7-9 (normal distribution: 23%)

Note: Percentages in table may not sum to 100% due to rounding. Data not reported for cells with fewer than ten students.

Leeward District DOE Standardized Test Scores, School Year (SY) 2001-2002

	Grade 3		Grade 5		Grade 8		Grade 10	
	Hawaiian	Others	Hawaiian	Others	Hawaiian	Others	Hawaiian	Others
SAT-9 Math								
Below average	41	25	43	23	47	33	51	36
Average	46	52	45	48	49	53	45	52
Above Average	13	23	11	29	4	14	4	12
SAT-9 Reading								
Below average	36	23	49	29	45	28	58	45
Average	58	64	46	55	49	59	40	50
Above Average	6	12	4	16	6	13	1	5
HCPS-II Math Standards								
Below	39	25	46	25	46	27	36	20
Approaches	53	60	50	56	50	56	60	63
Meets	8	15	4	18	4	16	4	16
Exceeds	-	1	-	1	-	1	-	1
HCPS-II Reading Standards								
Below	17	9	20	8	21	11	16	8
Approaches	59	50	57	49	58	48	65	50
Meets	23	39	23	41	21	39	20	40
Exceeds	1	1	-	1	1	2	-	1

Source: Kamehameha Schools, Hawai'i Content and Performance Standards (HCPS) II, School Year 2001-02 and SAT-9 Performance of Hawaiian Students in the DOE, School Year 2001-02, PASE Reports: 03-04:02, 03-04:03, 03-04:04, 03-04:05, 03-04:20, 03-04:21, 03-04:22, 03-04:23.

* column percentages, unless otherwise noted

*Below Average = stanine score of 1 - 3 (normal distribution: 23%)

*Average = stanine score of 4 - 6 (normal distribution: 54%)

*Above Average = stanine score of 7 - 9 (normal distribution: 23%)

Note: Percentages in table may not sum to 100% due to rounding. Data not reported for cells with fewer than ten students.

Leeward District DOE Standardized Test Scores, School Year (SY) 2002-2003

	Grade 3		Grade 5		Grade 8		Grade 10	
	Hawaiian	Others	Hawaiian	Others	Hawaiian	Others	Hawaiian	Others
SAT-9 Math								
Below average	31	21	40	25	39	28	50	38
Average	57	60	49	56	54	55	47	57
Above Average	12	20	11	19	7	17	3	5
SAT-9 Reading								
Below average	33	20	42	26	38	27	51	39
Average	57	61	51	57	53	55	48	57
Above Average	11	19	6	18	9	17	1	5
HCPS-II Math Standards								
Below	33	21	40	24	49	32	28	16
Approaches	56	56	53	58	48	56	69	72
Meets	11	21	6	17	3	11	3	11
Exceeds	1	2	-	1	-	1	-	-
HCPS-II Reading Standards								
Below	17	10	27	14	16	9	18	7
Approaches	58	50	49	44	62	53	69	59
Meets	24	39	24	41	22	37	13	33
Exceeds	-	1	-	1	-	1	-	1
Total number of test takers	880	2,236	920	2,251	839	2,005	580	1,799

Source: Kamehameha Schools, Snapshot of Hawaiians in the DOE: PASE Report 04-05:10.

*column percentages, unless otherwise noted

*Below average = stanine score of 1-3 (normal distribution: 23%)

*Average = stanine score of 4-6 (normal distribution: 54%)

*Above Average = stanine score of 7-9 (normal distribution: 23%)

Note: Percentages in table may not sum to 100% due to rounding. Data not reported for cells with fewer than ten students.

Windward District DOE Standardized Test Scores, School Year (SY) 2001-2002

	Grade 3		Grade 5		Grade 8		Grade 10	
	Hawaiian	Others	Hawaiian	Others	Hawaiian	Others	Hawaiian	Others
SAT-9 Math								
Below average	23	14	26	14	22	15	37	25
Average	56	45	52	48	62	56	52	53
Above Average	20	42	22	38	16	28	11	21
SAT-9 Reading								
Below average	24	12	30	18	26	16	45	32
Average	66	63	58	56	64	60	54	58
Above Average	10	25	11	26	10	24	1	10
HCPS-II Math Standards								
Below	24	12	28	16	23	12	23	11
Approaches	62	56	62	59	63	57	67	58
Meets	13	29	10	22	13	29	10	29
Exceeds	1	2	-	2	1	2	-	2
HCPS-II Reading Standards								
Below	10	6	10	5	6	4	5	5
Approaches	55	39	54	42	55	42	66	45
Meets	34	51	36	51	38	53	28	49
Exceeds	1	3	-	2	1	1	-	1

Source: Kamehameha Schools, Hawai'i Content and Performance Standards (HCPS) II, School Year 2001-02 and SAT-9 Performance of Hawaiian Students in the DOE, School Year 2001-02, PASE Reports: 03-04:02, 03-04:03, 03-04:04, 03-04:05, 03-04:20, 03-04:21, 03-04:22, 03-04:23.

* column percentages, unless otherwise noted

*Below Average = stanine score of 1 - 3 (normal distribution: 23%)

*Average = stanine score of 4 - 6 (normal distribution: 54%)

*Above Average = stanine score of 7 - 9 (normal distribution: 23%)

Note: Percentages in table may not sum to 100% due to rounding. Data not reported for cells with fewer than ten students.

Windward District DOE Standardized Test Scores, School Year (SY) 2002-2003

	Grade 3		Grade 5		Grade 8		Grade 10	
	Hawaiian	Others	Hawaiian	Others	Hawaiian	Others	Hawaiian	Others
SAT-9 Math								
Below average	18	9	27	14	31	18	43	25
Average	62	57	56	58	56	51	52	66
Above Average	19	34	17	29	13	31	5	9
SAT-9 Reading								
Below average	21	11	30	14	32	18	46	27
Average	62	56	58	58	55	51	52	64
Above Average	17	33	12	27	13	31	2	9
HCPS-II Math Standards								
Below	19	11	32	18	35	21	24	16
Approaches	62	58	58	61	55	54	70	66
Meets	18	28	9	20	10	24	6	17
Exceeds	1	3	-	1	-	1	-	1
HCPS-II Reading Standards								
Below	10	6	24	10	14	7	12	8
Approaches	53	38	47	39	59	48	60	49
Meets	36	56	29	49	27	43	28	43
Exceeds	1	1	-	1	-	2	-	-
Total number of test takers	539	870	545	908	488	763	421	785

Source: Kamehameha Schools, Snapshot of Hawaiians in the DOE: PASE Report 04-05:10.

*column percentages, unless otherwise noted

*Below average = stanine score of 1-3 (normal distribution: 23%)

*Average = stanine score of 4-6 (normal distribution: 54%)

*Above Average = stanine score of 7-9 (normal distribution: 23%)

Note: Percentages in table may not sum to 100% due to rounding. Data not reported for cells with fewer than ten students.

Kaua'i District DOE Standardized Test Scores, School Year (SY) 2001-2002

	Grade 3		Grade 5		Grade 8		Grade 10	
	Hawaiian	Others	Hawaiian	Others	Hawaiian	Others	Hawaiian	Others
SAT-9 Math								
Below average	26	16	23	13	32	21	29	28
Average	50	48	52	47	55	52	58	53
Above Average	24	36	24	40	13	26	14	19
SAT-9 Reading								
Below average	26	21	36	20	35	26	48	37
Average	67	60	54	57	56	53	48	57
Above Average	7	20	10	23	9	21	5	7
HCPS-II Math Standards								
Below	29	17	28	15	29	18	16	14
Approaches	58	58	59	61	58	48	68	60
Meets	13	23	11	22	12	31	16	25
Exceeds	-	2	1	2	1	3	-	1
HCPS-II Reading Standards								
Below	13	7	14	7	17	9	7	9
Approaches	56	47	55	48	55	41	57	45
Meets	31	43	31	45	28	47	35	44
Exceeds	-	2	-	1	1	3	-	2

Source: Kamehameha Schools, Hawai'i Content and Performance Standards (HCPS) II, School Year 2001-02 and SAT-9 Performance of Hawaiian Students in the DOE, School Year 2001-02, PASE Reports: 03-04:02, 03-04:03, 03-04:04, 03-04:05, 03-04:20, 03-04:21, 03-04:22, 03-04:23.

* column percentages, unless otherwise noted

*Below Average = stanine score of 1 - 3 (normal distribution: 23%)

*Average = stanine score of 4 - 6 (normal distribution: 54%)

*Above Average = stanine score of 7 - 9 (normal distribution: 23%)

Note: Percentages in table may not sum to 100% due to rounding. Data not reported for cells with fewer than ten students.

Kaua'i District DOE Standardized Test Scores, School Year (SY) 2002-2003

	Grade 3		Grade 5		Grade 8		Grade 10	
	Hawaiian	Others	Hawaiian	Others	Hawaiian	Others	Hawaiian	Others
SAT-9 Math								
Below average	27	12	30	18	43	20	39	29
Average	61	61	55	58	50	59	57	64
Above Average	12	27	15	24	7	20	4	7
SAT-9 Reading								
Below average	28	14	38	20	42	24	42	30
Average	62	59	53	59	51	57	57	64
Above Average	11	27	8	21	7	20	1	6
HCPS-II Math Standards								
Below	24	13	34	17	42	21	21	11
Approaches	64	59	57	63	50	58	66	66
Meets	12	25	8	19	7	20	13	22
Exceeds	-	3	-	1	-	1	-	1
HCPS-II Reading Standards								
Below	12	6	22	13	16	7	15	9
Approaches	61	46	53	43	60	48	57	46
Meets	26	45	24	44	24	44	28	44
Exceeds	-	2	-	-	-	1	-	-
Total number of test takers	246	518	262	519	243	566	177	590

Source: Kamehameha Schools, Snapshot of Hawaiians in the DOE: PASE Report 04-05:10.

*column percentages, unless otherwise noted

*Below average = stanine score of 1-3 (normal distribution: 23%)

*Average = stanine score of 4-6 (normal distribution: 54%)

*Above Average = stanine score of 7-9 (normal distribution: 23%)

Note: Percentages in table may not sum to 100% due to rounding. Data not reported for cells with fewer than ten students.

Maui District DOE Standardized Test Scores, School Year (SY) 2001-2002

	Grade 3		Grade 5		Grade 8		Grade 10	
	Hawaiian	Others	Hawaiian	Others	Hawaiian	Others	Hawaiian	Others
SAT-9 Math								
Below average	26	18	28	16	39	26	47	38
Average	53	50	49	50	55	57	48	48
Above Average	20	33	22	34	7	17	6	14
SAT-9 Reading								
Below average	28	18	38	25	34	26	51	42
Average	61	64	51	53	61	59	44	50
Above Average	11	18	11	22	6	15	4	8
HCPS-II Math Standards								
Below	29	19	30	19	37	22	23	21
Approaches	60	60	59	61	56	60	67	58
Meets	11	20	10	19	6	17	9	20
Exceeds	1	2	1	1	-	1	-	2
HCPS-II Reading Standards								
Below	11	7	14	8	12	8	14	12
Approaches	57	46	56	47	55	49	54	45
Meets	32	45	29	44	33	41	32	42
Exceeds	-	2	-	1	-	1	-	2

Source: Kamehameha Schools, Hawai'i Content and Performance Standards (HCPS) II, School Year 2001-02 and SAT-9 Performance of Hawaiian Students in the DOE, School Year 2001-02, PASE Reports: 03-04:02, 03-04:03, 03-04:04, 03-04:05, 03-04:20, 03-04:21, 03-04:22, 03-04:23.

* column percentages, unless otherwise noted

*Below Average = stanine score of 1 - 3 (normal distribution: 23%)

*Average = stanine score of 4 - 6 (normal distribution: 54%)

*Above Average = stanine score of 7 - 9 (normal distribution: 23%)

Note: Percentages in table may not sum to 100% due to rounding. Data not reported for cells with fewer than ten students.

Maui District DOE Standardized Test Scores, School Year (SY) 2002-2003

	Grade 3		Grade 5		Grade 8		Grade 10	
	Hawaiian	Others	Hawaiian	Others	Hawaiian	Others	Hawaiian	Others
SAT-9 Math								
Below average	28	14	31	20	35	25	38	33
Average	58	55	57	57	57	52	58	59
Above Average	14	30	12	23	9	22	4	8
SAT-9 Reading								
Below average	26	14	33	21	37	25	41	33
Average	63	57	60	58	55	52	58	60
Above Average	11	29	7	21	8	23	2	7
HCPS-II Math Standards								
Below	29	16	34	20	44	28	22	18
Approaches	59	59	57	61	52	56	72	63
Meets	12	23	9	17	4	15	6	17
Exceeds	-	2	-	1	-	1	-	1
HCPS-II Reading Standards								
Below	14	7	23	12	18	12	9	7
Approaches	58	45	52	48	65	50	64	49
Meets	28	46	25	40	17	37	28	43
Exceeds	1	2	-	1	-	1	-	1
Total number of test takers	429	1,096	473	1,162	511	1,134	423	1,136

Source: Kamehameha Schools, Snapshot of Hawaiians in the DOE: PASE Report 04-05:10.

*column percentages, unless otherwise noted

*Below average = stanine score of 1-3 (normal distribution: 23%)

*Average = stanine score of 4-6 (normal distribution: 54%)

*Above Average = stanine score of 7-9 (normal distribution: 23%)

Note: Percentages in table may not sum to 100% due to rounding. Data not reported for cells with fewer than ten students.

Maui District (Maui) DOE Standardized Test Scores, School Year (SY) 2002-2003

	Grade 3		Grade 5		Grade 8		Grade 10	
	Hawaiian	Others	Hawaiian	Others	Hawaiian	Others	Hawaiian	Others
SAT-9 Math								
Below average	22	13	29	20	34	25	36	33
Average	62	56	58	57	57	52	59	59
Above Average	16	31	13	23	9	23	5	8
SAT-9 Reading								
Below average	21	13	32	21	36	24	40	33
Average	65	57	60	58	56	52	58	59
Above Average	13	30	8	21	8	24	2	7
HCPS-II Math Standards								
Below	23	15	33	21	42	27	21	18
Approaches	63	59	58	61	54	56	72	63
Meets	13	24	9	17	4	16	7	18
Exceeds	1	2	-	1	-	1	-	1
HCPS-II Reading Standards								
Below	12	7	20	12	17	11	10	8
Approaches	56	45	54	48	65	50	60	49
Meets	31	46	26	39	18	38	31	43
Exceeds	1	2	-	1	-	1	-	1
Total number of test takers	338	1,029	372	1,088	373	1,064	328	1,047

Source: Kamehameha Schools, Snapshot of Hawaiians in the DOE: PASE Report 04-05:10.

*column percentages, unless otherwise noted

*Below average = stanine score of 1-3 (normal distribution: 23%)

*Average = stanine score of 4-6 (normal distribution: 54%)

*Above Average = stanine score of 7-9 (normal distribution: 23%)

Note: Percentages in table may not sum to 100% due to rounding. Data not reported for cells with fewer than ten students.

Maui District (Lānaʻi) DOE Standardized Test Scores, School Year (SY) 2002-2003

	Grade 3		Grade 5		Grade 8		Grade 10	
	Hawaiian	Others	Hawaiian	Others	Hawaiian	Others	Hawaiian	Others
SAT-9 Math								
Below average	62	26	N/A	20	58	32	55	47
Average	31	57	N/A	62	33	59	45	44
Above Average	6	17	N/A	18	8	9	-	8
SAT-9 Reading								
Below average	47	21	18	24	62	40	N/A	42
Average	47	57	55	65	31	50	N/A	50
Above Average	6	21	27	11	6	10	N/A	8
HCPS-II Math Standards								
Below	59	23	18	9	60	45	N/A	18
Approaches	35	60	64	80	40	50	N/A	79
Meets	6	14	18	11	-	5	N/A	-
Exceeds	-	2	-	-	-	-	N/A	3
HCPS-II Reading Standards								
Below	24	17	9	11	50	18	N/A	6
Approaches	71	50	9	48	31	65	N/A	58
Meets	6	33	82	41	19	18	N/A	36
Exceeds	-	-	-	-	-	-	N/A	-
Total number of test takers	17	43	11	46	16	40	N/A	36

Source: Kamehameha Schools, Snapshot of Hawaiians in the DOE: PASE Report 04-05:10.

*column percentages, unless otherwise noted

*Below average = stanine score of 1-3 (normal distribution: 23%)

*Average = stanine score of 4-6 (normal distribution: 54%)

*Above Average = stanine score of 7-9 (normal distribution: 23%)

Note: Percentages in table may not sum to 100% due to rounding. Data not reported for cells with fewer than ten students.

Maui District (Moloka'i) DOE Standardized Test Scores, School Year (SY) 2002-2003

	Grade 3		Grade 5		Grade 8		Grade 10	
	Hawaiian	Others	Hawaiian	Others	Hawaiian	Others	Hawaiian	Others
SAT-9 Math								
Below average	43	30	42	12	33	40	44	16
Average	49	45	50	54	58	47	53	67
Above Average	8	25	8	33	8	13	3	16
SAT-9 Reading								
Below average	42	33	42	36	36	40	45	21
Average	55	43	57	50	57	53	55	67
Above Average	3	24	1	14	7	7	-	12
HCPS-II Math Standards								
Below	45	43	43	21	47	38	27	17
Approaches	47	33	50	64	48	54	72	62
Meets	8	24	7	11	5	8	2	21
Exceeds	-	-	-	4	-	-	-	-
HCPS-II Reading Standards								
Below	19	19	34	14	15	37	6	5
Approaches	64	43	49	46	72	30	75	45
Meets	16	38	17	39	14	33	19	50
Exceeds	-	-	-	-	-	-	-	-
Total number of test takers	74	22	90	28	122	30	72	44

Source: Kamehameha Schools, Snapshot of Hawaiians in the DOE: PASE Report 04-05:10.

*column percentages, unless otherwise noted

*Below average = stanine score of 1-3 (normal distribution: 23%)

*Average = stanine score of 4-6 (normal distribution: 54%)

*Above Average = stanine score of 7-9 (normal distribution: 23%)

Note: Percentages in table may not sum to 100% due to rounding. Data not reported for cells with fewer than ten students.

Hawai'i District DOE Standardized Test Scores, School Year (SY) 2001-2002

	Grade 3		Grade 5		Grade 8		Grade 10	
	Hawaiian	Others	Hawaiian	Others	Hawaiian	Others	Hawaiian	Others
SAT-9 Math								
Below average	38	19	28	17	36	22	47	56
Average	47	50	52	46	54	53	48	51
Above Average	14	31	20	37	10	25	5	13
SAT-9 Reading								
Below average	19	27	38	24	35	22	51	35
Average	50	49	52	49	58	56	47	56
Above Average	31	24	10	27	7	22	3	9
HCPS-II Math Standards								
Below	36	19	28	18	34	19	34	22
Approaches	55	57	61	54	59	54	60	58
Meets	9	22	11	26	7	24	6	20
Exceeds	-	1	-	2	-	2	-	-
HCPS-II Reading Standards								
Below	19	8	9	5	13	7	13	8
Approaches	53	42	60	43	61	41	59	43
Meets	27	47	31	50	26	50	27	47
Exceeds	1	3	-	2	1	3	-	2

Source: Kamehameha Schools, Hawai'i Content and Performance Standards (HCPS) II, School Year 2001-02 and SAT-9 Performance of Hawaiian Students in the DOE, School Year 2001-02, PASE Reports: 03-04:02, 03-04:03, 03-04:04, 03-04:05, 03-04:20, 03-04:21, 03-04:22, 03-04:23.

* column percentages, unless otherwise noted

*Below Average = stanine score of 1 - 3 (normal distribution: 23%)

*Average = stanine score of 4 - 6 (normal distribution: 54%)

*Above Average = stanine score of 7 - 9 (normal distribution: 23%)

Note: Percentages in table may not sum to 100% due to rounding. Data not reported for cells with fewer than ten students.

Hawai'i District DOE Standardized Test Scores, School Year (SY) 2002-2003

	Grade 3		Grade 5		Grade 8		Grade 10	
	Hawaiian	Others	Hawaiian	Others	Hawaiian	Others	Hawaiian	Others
SAT-9 Math								
Below average	27	15	32	21	34	22	44	29
Average	59	57	54	53	57	55	53	61
Above Average	14	27	14	26	9	23	4	11
SAT-9 Reading								
Below average	27	16	34	21	34	21	44	29
Average	61	56	58	56	59	56	68	61
Above Average	11	26	10	24	9	25	3	10
HCPS-II Math Standards								
Below	28	17	34	21	37	24	24	17
Approaches	61	56	58	56	59	56	68	61
Meets	10	23	8	20	4	18	8	20
Exceeds	1	3	-	2	-	2	-	2
HCPS-II Reading Standards								
Below	17	9	24	14	13	7	12	8
Approaches	52	45	50	39	64	50	58	45
Meets	30	44	25	45	23	42	30	46
Exceeds	1	2	1	1	-	1	-	1
Total number of test takers	709	1,137	813	1,312	723	1,226	666	1,212

Source: Kamehameha Schools, Snapshot of Hawaiians in the DOE: PASE Report 04-05:10.

*column percentages, unless otherwise noted

*Below average = stanine score of 1-3 (normal distribution: 23%)

*Average = stanine score of 4-6 (normal distribution: 54%)

*Above Average = stanine score of 7-9 (normal distribution: 23%)

Note: Percentages in table may not sum to 100% due to rounding. Data not reported for cells with fewer than ten students.

Hawai'i District (East) DOE Standardized Test Scores, School Year (SY) 2002-2003

	Grade 3		Grade 5		Grade 8		Grade 10	
	Hawaiian	Others	Hawaiian	Others	Hawaiian	Others	Hawaiian	Others
SAT-9 Math								
Below average	29	15	38	21	37	20	44	30
Average	60	59	51	52	57	55	51	59
Above Average	12	26	11	27	7	25	4	11
SAT-9 Reading								
Below average	30	16	40	23	35	20	48	31
Average	60	60	53	52	59	55	49	59
Above Average	11	24	7	26	7	26	3	10
HCPS-II Math Standards								
Below	32	20	39	21	39	23	25	18
Approaches	61	57	52	56	58	54	66	58
Meets	6	21	8	20	4	20	9	21
Exceeds	-	3	-	3	-	3	-	2
HCPS-II Reading Standards								
Below	20	10	28	14	17	7	13	8
Approaches	53	43	52	39	65	49	56	44
Meets	27	44	20	45	18	42	30	47
Exceeds	1	2	-	2	-	1	-	1
Total number of test takers	403	637	424	753	368	705	385	688

Source: Kamehameha Schools, Snapshot of Hawaiians in the DOE: PASE Report 04-05:10.

*column percentages, unless otherwise noted

*Below average = stanine score of 1-3 (normal distribution: 23%)

*Average = stanine score of 4-6 (normal distribution: 54%)

*Above Average = stanine score of 7-9 (normal distribution: 23%)

Note: Percentages in table may not sum to 100% due to rounding. Data not reported for cells with fewer than ten students.

Hawai'i District (West) DOE Standardized Test Scores, School Year (SY) 2002-2003

	Grade 3		Grade 5		Grade 8		Grade 10	
	Hawaiian	Others	Hawaiian	Others	Hawaiian	Others	Hawaiian	Others
SAT-9 Math								
Below average	24	16	26	22	30	24	42	27
Average	60	55	57	55	57	54	55	63
Above Average	16	29	17	23	13	22	3	10
SAT-9 Reading								
Below average	24	16	28	20	32	22	40	27
Average	64	55	59	58	56	53	58	63
Above Average	12	29	13	22	12	25	2	10
HCPS-II Math Standards								
Below	22	15	29	21	36	25	22	16
Approaches	61	56	62	58	59	60	72	65
Meets	16	24	8	21	5	15	7	18
Exceeds	2	4	1	1	-	-	-	1
HCPS-II Reading Standards								
Below	13	8	19	15	9	6	12	7
Approaches	52	46	49	39	60	51	59	45
Meets	34	45	31	45	30	43	29	47
Exceeds	1	1	1	1	1	-	-	1
Total number of test takers	274	458	336	506	303	471	248	490

Source: Kamehameha Schools, Snapshot of Hawaiians in the DOE: PASE Report 04-05:10.

*column percentages, unless otherwise noted

*Below average = stanine score of 1-3 (normal distribution: 23%)

*Average = stanine score of 4-6 (normal distribution: 54%)

*Above Average = stanine score of 7-9 (normal distribution: 23%)

Note: Percentages in table may not sum to 100% due to rounding. Data not reported for cells with fewer than ten students.

Ethnic Background of Credit Students, By Campus, University of Hawai'i: Fall 2003

Ethnicity	UH Mānoa		UH Hilo		UH West O'ahu		UH Community Colleges	
	Number	Percent	Number	Percent	Number	Percent	Number	Percent
Hawaiian / Part Hawaiian	1,579	7.9	519	15.7	129	15.9	4,608	17.5
Asian	8,443	42.5	704	21.3	275	34.0	10,802	41.0
Caucasian	4,840	24.4	1,271	38.5	210	25.9	4,305	16.3
African American	181	0.9	42	1.3	15	1.9	304	1.2
Hispanic	373	1.9	83	2.5	22	2.7	586	2.2
American Indian / Alaska Native	59	0.3	20	0.6	3	0.4	90	0.3
Other Pacific Islander	377	1.9	153	4.6	15	1.9	356	1.4
Mixed Ethnic Background	2,081	10.5	387	11.7	101	12.5	3,401	12.9
No Response	947	4.8	2	0.1	15	1.9	546	2.1

Source: University of Hawai'i Student Information Management System (SIMS), compiled by UH Institutional Research Office

Ethnic Background of Credit Students, By Campus, University of Hawai'i: Fall 2004

Ethnicity	UH Mānoa		UH Hilo		UH West O'ahu		UH Community Colleges	
	Number	Percent	Number	Percent	Number	Percent	Number	Percent
Hawaiian / Part Hawaiian	1,632	7.9	518	15.8	157	18.8	4,465	17.2
Asian	8,458	41.2	704	21.4	277	33.2	10,517	40.6
Caucasian	5,362	26.1	1,252	38.1	190	22.8	4,181	16.1
African American	215	1.0	45	1.4	15	1.8	285	1.1
Hispanic	422	2.1	99	3.0	26	3.1	516	2.0
American Indian / Alaska Native	76	0.4	21	0.6	3	0.4	90	0.3
Other Pacific Islander	250	1.2	132	4.0	10	1.2	267	1.0
Mixed Ethnic Background	2,138	10.4	384	11.7	119	14.3	3,488	13.5
No Response	754	3.7	2	0.1	1	0.1	616	2.4

Source: University of Hawai'i Student Information Management System (SIMS), compiled by UH Institutional Research Office

University of Hawai'i Degrees and Certificates Earned by Degree Type, and Ethnicity: July 1, 2002 - June 30, 2003

Degrees	Asian / Pacific Islander					Other				
	Japanese	Chinese	Filipino	Hawaiian / Part Hawaiian	Pacific Islander	Caucasian	Hispanic	African American	Mixed Background	No Response
Certificate of Achievement (CA)	39	10	110	64	2	41	11	-	21	7
Associate in Arts (AA)	194	48	169	165	19	207	28	14	168	5
Associate in Applied Sci/Sci/Tech St (AAS, AS, ATS)	254	74	266	228	16	151	30	18	113	14
Bachelor's Degrees (BA, BS, etc.)	722	308	276	335	97	563	37	26	308	5
Professional Diploma (PD), Certificate in Ed (Ced)	17	3	7	11	-	24	2	-	8	-
Master's Degrees (MA, MS, etc.)	215	114	42	72	18	302	12	12	89	44
Doctor's Degrees (PhD, EdD, DrPH)	16	13	2	4	2	65	1	2	4	5
First Professional Degrees (JD, MD, ArchD)	22	15	10	12	6	27	3	-	11	5
TOTAL	1,479	585	882	891	160	1,380	124	72	722	85

Source: Student Information Management System (SIMS), compiled by the Institutional Research Office

University of Hawai'i Degrees and Certificates Earned by Degree Type, and Ethnicity: July 1, 2003 - June 30, 2004

Degrees	Asian / Pacific Islander					Other				
	Japanese	Chinese	Filipino	Hawaiian / Part Hawaiian	Other Pacific Islander	Caucasian	Hispanic	African American	Mixed Background	No Response
Certificate of Achievement (CA)	46	8	81	58	3	53	9	1	22	5
Associate in Arts (AA)	186	55	148	198	10	212	35	20	167	9
Associate in Applied Sci/Sci/Tech St (AAS, AS, ATS)	222	49	220	184	24	188	25	12	123	15
Bachelor's Degrees (BA, BS, etc.)	745	291	292	332	83	715	48	18	374	52
Professional Diploma (PD), Certificate in Ed (Ced)	27	4	4	22	-	55	4	-	18	-
Master's Degrees (MA, MS, etc.)	218	140	40	59	15	353	14	9	79	33
Doctor's Degrees (PhD, EdD, DrPH)	7	16	3	3	1	54	2	-	9	3
First Professional Degrees (JD, MD, ArchD)	34	19	8	16	4	25	3	-	14	6
TOTAL	1,485	582	796	872	140	1,655	140	60	806	123

Source: Student Information Management System (SIMS), compiled by the Institutional Research Office

**Ethnic Background of University of Hawai'i Instructional Faculty
and Community College Personnel: Fall 2002**

Ethnicity	UH Mānoa		UH Hilo		UH West O'ahu		UH Community Colleges	
	Number	Percent	Number	Percent	Number	Percent	Number	Percent
Hawaiian / Part Hawaiian	56	3.8	10	6.1	-	-	69	7.5
Japanese	189	12.9	23	14.1	4	17.4	252	27.6
Chinese	137	9.3	5	3.1	1	4.3	60	6.6
Filipino	24	1.6	-	-	-	-	40	4.4
Korean	32	2.2	4	2.5	-	-	13	1.4
Samoaan	4	0.3	-	-	-	-	2	0.2
Caucasian	910	62.1	112	68.7	16	69.6	438	47.9
African American	8	0.5	2	1.2	-	-	7	0.8
Hispanic	22	1.5	5	3.1	1	4.3	5	0.5
American Indian / Alaska Native	6	0.4	1	0.6	-	-	4	0.4
Other Asian & Pacific Islander	34	2.3	-	-	1	4.3	13	1.4
Unknown	4	0.3	-	-	-	-	3	0.3

Source: University of Hawai'i, Office of Human Resources Data Warehouse. Extracted data were edited as provided by Office of Human resources and compiled by Institutional Research Office.

Note: Includes full-time and part-time personnel. Includes persons on leave without pay.

**Ethnic Background of University of Hawai'i Instructional Faculty
and Community College Personnel: Fall 2003**

Ethnicity	UH Mānoa		UH Hilo		UH West O'ahu		UH Community Colleges	
	Number	Percent	Number	Percent	Number	Percent	Number	Percent
Hawaiian / Part Hawaiian	60	0.4	13	7.5	-	-	77	8.4
Japanese	185	12.3	21	12.1	4	18.2	251	27.5
Chinese	136	9.1	5	2.9	1	4.5	58	6.4
Filipino	26	7.1	-	-	-	-	40	4.4
Korean	35	2.3	4	2.3	-	-	13	1.4
Samoaan	4	0.3	-	-	-	-	2	0.2
Caucasian	927	61.9	119	68.4	15	68.2	432	47.3
African American	8	0.5	2	1.1	-	-	5	0.5
Hispanic	27	1.8	6	3.4	1	4.5	5	0.5
American Indian / Alaska Native	7	0.5	1	0.6	-	-	5	0.5
Other Asian & Pacific Islander	37	2.5	-	-	1	4.5	13	1.4
Unknown	8	0.5	1	0.6	-	-	4	0.4

Source: University of Hawai'i, Office of Human Resources Data Warehouse. Extracted data were edited as provided by Office of Human resources and compiled by Institutional Research Office.

Note: Includes full-time and part-time personnel. Includes persons on leave without pay.

EDUCATION RESOURCES

Bishop Museum – Education Division

1525 Bernice Street
Honolulu, HI 96817
Ph: (808) 847-3511
Fax: (808) 841-8968
Website: <http://www.bishopmuseum.org/education/education.html>

Charter Schools Administration Office

1111 Bishop Street, Suite 516
Honolulu, HI 96813
Phone: (808) 586-3775
Fax: (808) 586-3776

Hawai'i State Department of Education

P.O. Box 2360
Honolulu, HI 96804
Phone: (808) 586-3230/3232
Fax: (808) 586-3234
Website: <http://doe.k12.hi.us>

Hawai'i State Department of Education Hawaiian Language Immersion Program

475 22nd Avenue
Honolulu, HI 96816
Website: <http://www.k12.hi.us/~kaiapuni/>

Kamehameha Schools

567 South King Street, Suite 400
Honolulu, HI 96813
Phone: (808) 523-6200
Fax: (808) 541-3505
Website: <http://www.ksbe.edu>

Nā Lei Na'auao Native Hawaiian Charter School Alliance

P.O. Box 6511
Kamuela, HI 96743
Phone: (808) 885-0328
Fax: (808) 887-0030

Nā Pua No'eau (head office)

200 West Kāwili Street
Hilo, HI 96720
Phone: (808) 974-7678
Fax: (808) 974-7681
Website: <http://www2.hawaii.edu/~nnp/npnhome.html>

Native Hawaiian Education Association

P.O. Box 240164
Honolulu, HI 96824
Website: <http://www.nhea.net/>

Native Hawaiian Education Council

3075 Kalihi Street, #4
Honolulu, HI 96819
Phone: (808) 845-9883
Fax: (808) 845-9984
Website: <http://www.nhec.us>

Pacific Resources for Education and Learning (PREL)

900 Fort Street Mall, Suite 1300
Honolulu, HI 96813
Phone: (808) 441-1300
Fax: (808) 441-1385
Toll free phone: (800) 377-4773
Toll free fax: (888) 512-7599
Website: <http://www.prel.org>

EARLY EDUCATION

'Aha Pūnana Leo Inc. (main office)

96 Pu'uhonu Place
Hilo, HI 96720
Phone: (808) 935-4304
Fax: (808) 969-7512
Website: <http://www.ahapunanaleo.org>

Good Beginnings Alliance

33 South King Street, #200
Honolulu, HI 96813
Phone: (808) 531-5502
Fax: (808) 531-5702
Website: <http://www.goodbeginnings.org/index.htm>

Ho'owaiwai Nā Kamali'i Early Childhood Consortium

King's Gate Plaza
555 North King Street, Suite 105
Honolulu, HI 96813
Phone: (808) 845-0275
Website: http://www.alulike.org/services/ho_hoo.html

Institute for Native Pacific Education and Culture (INPEACE)

91-110 Hanua Street
Kapolei, HI 96707

Phone: (808) 690-8097
Fax: (808) 690-8099
Website: <http://www.inpeace.hawaii.org>

Keiki o ka 'Āina Family Learning Centers

3030 Kalihi Street
Honolulu, HI 96819
Phone: (808) 843-2502
Fax: (808) 843-2572
Website: <http://www.keikiokaaina.org/index.htm>

Nā Kamalei – K.E.E.P

Ho'āla Nā Pua
P.O. Box 900
Hau'ula, HI 96717
Phone: (808) 237-8500
Fax: (808) 237-8501
Website: <http://www.nakamalei.org>

Tūtū and Me (Partners in Development)

2345 Nu'uanu Avenue
Honolulu, HI 96817
Phone: (808) 524-7633
Website: <http://tutuandme.org/index.html>

Wai'anae Coast Early Childhood Services

84-1061 Noholio Road
Wai'anae, HI 96792
Phone: (808) 695-9656
Fax: (808) 695-9401

SPECIAL NEEDS

Pihana Nā Mamo (The Native Hawaiian Special Education Project)

475 22nd Avenue, Building 302, Room 216
Honolulu, HI 96816
Phone: (808) 733-9141 x 234
Fax: (808) 735-8227
Website: <http://www.k12.hi.us/~pihana>

HIGHER EDUCATION

College Connections Hawai'i

3465 Wai'alae Avenue, Suite 300-B
Honolulu, HI 96816
Phone: (808) 737-8955
Fax: (808) 737-8966

Website: <http://www.collegeconnections.org/>

Kamakakūokalani Center for Hawaiian Studies (UHM)

2645 Dole Street, Rm. 209A
Honolulu, HI 96822
Phone: (808) 973-0989
Fax: (808) 973-0988
Website: <http://www.hawaii.edu/chs>

Kua'ana Native Hawaiian Development Services

2600 Campus Road, QLCSS Rm. 207
Honolulu, HI 96822
Phone: (808) 956-2644
Fax: (808) 956-9880
Website: <http://www.hawaii.edu/kuaana/index.html>

Native Hawaiian Center for Excellence (UHM)

651 Ilalo Street
Honolulu, HI 96813
Phone: (808) 692-1040
Fax: (808) 692-1255
Website: <http://www.hawaii.edu/nhcoe>

University of Hawai'i at Hilo, College of Hawaiian Language

200 West Kāwili Street
Hilo, HI 96720
Phone: (808) 974-7342
Fax: (808) 974-7736
Website: <http://www.olelo.hawaii.edu/dual/orgs/keelikolani/>

University of Hawai'i at Mānoa, Hawaiian and Indo-Pacific Languages and Literature Program

2540 Maile Way, Spaulding 255
Honolulu, HI 96822
Phone: (808) 956-8672 or 956-7542
Fax: (808) 956-5978
Website: <http://www.hawaii.edu/hipll>

LITERACY

Hawai'i Family Literacy Consortium

595 Pepe'ekeo St. Bldg. H-1
Honolulu, HI 96825
Telephone: (808) 394-1385

Fax: (808) 394-1388
Website: <http://literacynet.org/hflc/index.html>

Hawai'i Literacy Inc.

200 North Vineyard Boulevard, Suite 320
Honolulu, HI 96817
Phone: (808) 537-6706
Fax: (808) 537-3072
Website: <http://www.hawaiiliteracy.org>

VOCATIONAL EDUCATION

Building Industry Association of Hawai'i Construction Training Center of the Pacific

1727 Dillingham Boulevard
Honolulu, HI 96819
Phone: (808) 847-4666 x210
Fax: (808) 842-0129
Website: <http://www.bia-hawaii.com/>

Hawai'i Job Corps Center

41-467 Hihimanu Street
Waimānalo, HI 96795
Phone: (808) 259-6010
Fax: (808) 259-7907

Hawai'i Technology Institute

629 Pohukaina Street
Honolulu, HI 96813
Phone: (808) 522-2700
Fax: (808) 522-2707
Website: <http://www.hti.edu>

Wai'anae Maritime Academy

P.O. Box 1601
Wai'anae, HI 96792
Phone: (808) 668-9200
Fax: (808) 696-4024

SCHOLARSHIPS

Gates Millennium Scholarship Program

1001 Connecticut Ave., N.W. Suite 725
Washington, D.C. 20036
Phone: 1-866-274-4677 ext.5
Website: www.ocanatl.org

Hawai'i Community Foundation

1164 Bishop St., Suite 800
Honolulu, HI 96813
Phone: (808) 537-6333
Toll-free phone: 1-888-731-3863
Website: www.hawaiicommunityfoundation.org

Hawaiian Homes Commission Scholarships

P.O. Box 1879
Honolulu, HI 96805
Phone: (808) 537-6333
Website: www.hawaii.gov/dhhl

Kamehameha Schools

Financial Aid and Scholarship Services

567 S. King Street, Suite 102
Honolulu HI 96813
Phone: (808) 534-8080
Toll free phone: 1-800-842-4682, dial 9, x48080
Website: www.ksbe.edu

Ke Ali'i Pauahi Foundation

567 S. King Street, Suite 160
Honolulu, HI 96813
Phone: (808) 534-3966
Toll free phone: 1-800-842-4682, dial 9, x43966
Website: www.pauahi.org

Liko A'e

310 Ka'ahumanu Avenue
Kahului, HI 96732
Phone: (808) 984-3366
Website: <http://www.likoae.org>

Native Hawaiian Health Scholarship Program

345 Queen St., Suite 706
Honolulu, HI 96813
Phone: (808) 585-8944
Website: www.nhhsp.com

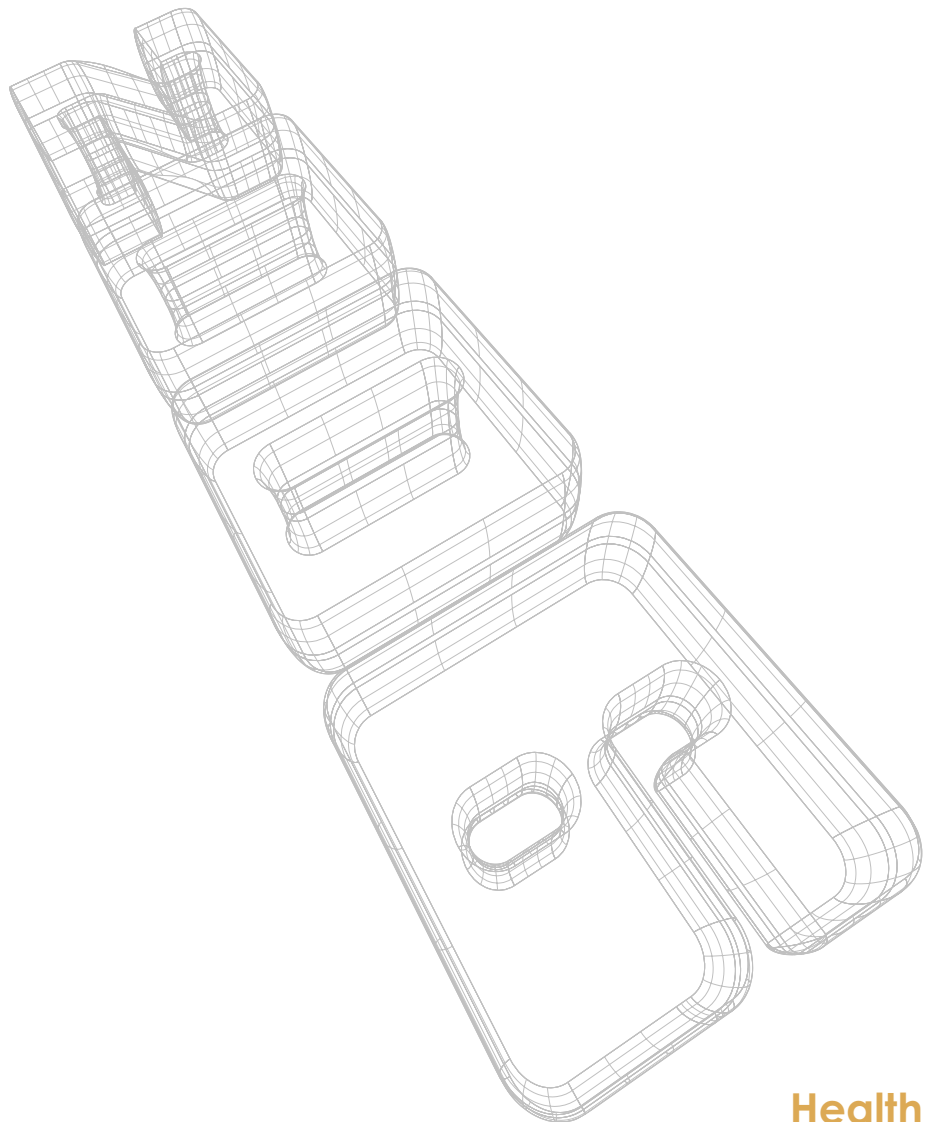

HEALTH

Native Hawaiians developed a sophisticated, well functioning system of health care based upon “ke ola pono”, concepts of wellness that are consistent with today's holistic healing practices combining mental, physical as well as spiritual beliefs systems and practices. By the end of the 18th century and a steady stream of haole foreign visitors from the East and West, native Hawaiians had to deal with an onslaught of infectious diseases that were deadly to their unsuspecting immune systems. Traditional healing and knowledge could not stem this devastating tide. Native Hawaiians had entered a process sometimes referred to as “cultural trauma” brought on by forced assimilation.

Disease incidence and mortality are strongly associated with lifestyle and risk factors. Of all racial groups living in Hawai'i, Native Hawaiians are the racial group with the highest proportion of risk factors leading to illness, disability, and premature death. Statistics reveal a high risk profile for Native Hawaiians, with the bulk of them having one of the following risk factors: sedentary life, obesity, hypertension, smoking, and acute drinking.

The data depicts Native Hawaiians are experiencing high rates of circulatory diseases and malignant neoplasms, particularly digestive and respiratory types, which appear to be strongly associated to risk factors such as smoking, alcohol consumption, obesity, sedentary life, and so on. The data also indicate that large segments of the Native Hawaiian population were recipients of state and federal sponsored health care services, a clear indication that low income is a barrier to full access to health care systems.

While our focus data is on the Native Hawaiian population, the user must also note that a few minority populations mirror our data. What is not in the data collected is information on Hawaiian health as compared to other Hawaiians. By understanding the current data on Native Hawaiians and the events that impact upon Hawai'i's host culture, policy makers and program developers may use the information to make system changes in service delivery, and plan for the availability and distribution of health care services to assure accessibility to Native Hawaiians and others.

Selected Chronic Conditions by Ethnicity - Total Number and Prevalence Per 1,000 Persons in Hawai'i, Hawai'i Health Survey (HHS) 2002

Chronic Condition	Ethnicity / Race						Total	
	Caucasian	Hawaiian	Chinese	Filipino	Japanese	Others Unknown Refused	Number	Prevalence/ per 1,000 persons
Arthritis	102.7	45.3	79.8	60.3	92.5	64.5	92,291	76.9
Asthma	73.9	128.3	98.8	64.1	80	68.8	102,488	85.4
Diabetes	30	46.5	56.8	33.6	86.5	48	58,689	48.9
High Blood Cholesterol	145.7	85.6	121.9	107.5	232.2	96.9	164,485	137
Hypertension	110.2	111	136.6	139.6	212	98.7	163,457	136.1
TOTAL	297,211	245,312	68,368	214,195	239,800	135,807	1,200,693	N/A

Source: Department of Health, Hawai'i Health Survey (HHS), Office of Health Status Monitoring

Note:

* Sample numbers provisionally weighted and adhysted for total population of Hawai'i (total number Manual 2002)

* Row and/or column totals may not sum to totals listed due to rounding

* Sample size 15,516 people

* (Prevalence not adjusted for age)

Number and Percent Overweight (including Obese) by County and Ethnicity - Adult Population of Hawai'i, Hawai'i Health Survey (HHS) 2002

Ethnicity	City & County of Honolulu		Hawai'i		Kauai		Maui		Total	
	Number	Percent	Number	Percent	Number	Percent	Number	Percent	Number	Percent
Caucasian	80,487	43.8%	19,068	43.5%	7,805	46.6%	18,249	41.5%	125,609	43.6%
Hawaiian	56,788	58.9%	15,463	62.6%	3,950	58.7%	11,231	61.0%	87,432	59.8%
Chinese	20,566	41.8%	*	*	*	*	*	*	22,101	41.2%
Filipino	44,351	49.1%	4,859	49.0%	3,582	42.7%	6,571	47.3%	59,363	48.4%
Japanese	68,579	42.5%	8,629	41.1%	3,296	41.3%	6,646	47.3%	87,150	42.7%
Other Unknown Refused	27,546	37.7%	6,054	50.8%	1,576	47.5%	3,718	46.8%	38,894	40.4%

Source: Hawai'i Department of Health, Hawai'i Health Survey (HHS), Office of Health Status Monitoring

Note:

* Overweight (BMI 25 - 29.9), Obese (BMI 30 and above) by Clinical Guidelines, NIH 1998

* Respondent only, aged 18 years and older

* Sample
telephones, Ni'ihau, group quarters, and homeless are not represented, see HHS Procedure Manual 2002)

* Row and/or column totals may not sum to totals listed due to rounding

* Sample size 2,430 overweight and obese adults out of 5,244 respondents

Adult Asthma Status - State of Hawai'i: 2003

Ethnicity	Current Asthma		No More Asthma		Never Had Asthma		TOTAL	Estimated # of Adults
	Number	Percent	Number	Percent	Number	Percent		
Caucasian	95	5.0	82	5.6	1,487	89.3	1,664	305,027
Hawaiian	63	10.3	38	5.6	511	84.1	612	132,562
Filipino	20	2.7	18	3.1	464	94.2	502	143,144
Japanese	30	4.1	45	6.9	703	88.9	778	185,885
Others	51	7.1	51	7.4	670	85.6	772	192,274

Source: Hawai'i State Department of Health, Behavioral Risk Factor Surveillance System (BRFSS)

High Blood Pressure Risk Factor - State of Hawai'i: 2003

Ethnicity	Not At Risk		At Risk		TOTAL	Estimated # of Adults
	Number	Percent	Number	Percent		
Caucasian	1,352	83.4	310	16.6	1,662	303,982
Hawaiian	434	72.1	178	27.9	612	132,562
Filipino	383	79.9	120	20.1	503	143,067
Japanese	502	64.2	278	35.8	780	186,165
Others	613	79.3	161	20.7	774	192,909

Source: Hawai'i State Department of Health, Behavioral Risk Factor Surveillance System

High Cholesterol Risk Factor - State of Hawai'i: 2003

Ethnicity	Not At Risk		At Risk		TOTAL	Estimated # of Adults
	Number	Percent	Number	Percent		
Caucasian	963	74.9	375	25.1	1,338	237,293
Hawaiian	316	70.5	131	29.5	447	92,960
Filipino	249	75.7	89	24.3	338	93,163
Japanese	435	68.3	216	31.7	651	151,344
Others	412	74.8	145	25.2	557	134,944

Source: Hawai'i State Department of Health, Behavioral Risk Factor Surveillance System

Smoking Status - State of Hawai'i: 2003

Ethnicity	Current Smoker		Former Smoker		Never Smoked		TOTAL	Estimated # of Adults
	Number	Percent	Number	Percent	Number	Percent		
Caucasian	273	16.5	518	29.2	871	54.3	1,662	304,557
Hawaiian	162	25.8	136	24.5	314	49.8	612	132,562
Filipino	64	14.5	77	15.8	363	69.7	504	143,709
Japanese	95	13.6	200	25.1	483	61.3	778	186,015
Others	137	18.0	167	21.2	471	60.8	775	193,207

Source: Hawai'i State Department of Health, Behavioral Risk Factor Surveillance System (BRFSS)

General Health Status - State of Hawai'i: 2003

Ethnicity	Excellent		Very Good		Good		Fair		Poor		Total	Estimated # of Adults
	Number	Percent	Number	Percent	Number	Percent	Number	Percent	Number	Percent		
Caucasian	510	32.0	608	35.8	400	24.6	104	5.5	41	2.1	1,663	304,990
Hawaiian	92	13.4	171	29.1	235	38.8	98	16.4	16	2.3	612	132,562
Filipino	101	23.3	129	22.8	202	40.4	58	11.5	13	2.0	503	143,290
Japanese	110	14.1	225	29.7	325	41.3	99	12.8	21	1.9	780	186,268
Others	158	20.3	269	34.8	248	33.3	82	10.2	17	1.4	774	192,620

Source: Hawai'i State Department of Health, Behavioral Risk Factor Surveillance System (BRFSS)

Health Insurance Status: Hawai'i Health Survey, 2003

Insurance Status	County									
	Honolulu		Hawai'i		Kaua'i		Maui		Total	
	Number	Percent	Number	Percent	Number	Percent	Number	Percent	Number	Percent
Statewide TOTAL	873,707	71.5%	154,527	12.6%	59,949	4.9%	134,099	11%	1,222,281	100%
Gender:										
Male	430,427	49.3%	77,283	50.0%	29,932	49.9%	67,221	50.1%	604,863	49.5%
Female	443,280	50.7%	77,243	50.0%	30,018	50.1%	66,878	49.9%	617,418	50.5%
Age:										
0 - 14 years	170,068	19.5%	30,663	19.8%	11,745	19.6%	26,856	20.0%	239,332	19.6%
15 - 17 years	34,115	3.9%	7,029	4.5%	2,835	4.7%	5,665	4.2%	49,644	4.1%
18 - 24 years	71,989	8.2%	14,457	9.4%	5,134	8.6%	11,306	8.4%	102,885	8.4%
25 - 34 years	115,019	13.2%	15,419	10.0%	5,921	9.9%	15,790	11.8%	152,149	12.4%
35 - 44 years	130,358	14.9%	19,962	12.9%	8,102	13.5%	20,344	15.2%	178,766	14.6%
45 - 54 years	125,719	14.4%	26,584	17.2%	10,315	17.2%	22,559	16.8%	185,177	15.2%
55 - 64 years	93,423	10.7%	18,381	11.9%	6,915	11.5%	14,877	11.1%	133,596	10.9%
65 - 74 years	57,932	6.6%	10,346	6.7%	3,934	6.6%	7,727	5.8%	79,939	6.5%
> 74 years	59,421	6.8%	10,144	6.6%	4,233	7.1%	7,439	5.5%	81,236	6.6%
Unknown / Refused	15,663	1.8%	1,542	1.0%	815	1.4%	1,537	1.1%	19,557	1.6%
Insurance Status:										
Insured	820,344	93.9%	137,000	88.7%	54,617	91.1%	120,795	90.1%	1,132,756	92.7%
Uninsured	34,430	3.9%	14,196	9.2%	4,214	7.0%	10,853	8.1%	63,693	5.2%
Unknown / Refused / Missing	18,933	2.2%	3,331	2.2%	1,119	1.9%	2,450	1.8%	25,833	2.1%

Health Insurance Status: Hawai'i Health Survey, 2003 - Continued

Insurance Status	County									
	Honolulu		Hawai'i		Kaua'i		Maui		Total	
	Number	Percent	Number	Percent	Number	Percent	Number	Percent	Number	Percent
Native Hawaiian TOTAL ...	169,964	65.8%	44,652	17.3%	13,532	5.2%	30,341	11.7%	258,490	21.1%
Gender:										
Male	82,207	48.4%	22,251	49.8%	6,777	50.1%	15,562	51.3%	126,797	49.1%
Female	87,757	51.6%	22,401	50.2%	6,755	49.9%	14,779	48.7%	131,693	50.9%
Age:										
0 - 14 years	52,096	30.7%	14,211	31.8%	4,275	31.6%	10,010	33.0%	80,593	31.2%
15 - 17 years	8,529	5.0%	3,084	6.9%	1,111	8.2%	2,384	7.9%	15,107	5.8%
18 - 24 years	16,547	9.7%	5,680	12.7%	1,860	13.7%	3,660	12.1%	27,747	10.7%
25 - 34 years	21,496	12.6%	5,615	12.6%	1,510	11.2%	3,175	10.5%	31,797	12.3%
35 - 44 years	28,899	17.0%	5,561	12.5%	1,482	11.0%	4,715	15.5%	40,656	15.7%
45 - 54 years	18,782	11.1%	4,154	9.3%	1,417	10.5%	2,834	9.3%	27,189	10.5%
55 - 64 years	12,734	7.5%	3,414	7.6%	898	6.6%	1,842	6.1%	18,888	7.3%
65 - 74 years	6,438	3.8%	1,847	4.1%	593	4.4%	781	2.6%	9,660	3.7%
> 74 years	3,439	2.0%	663	1.5%	305	2.3%	771	2.5%	5,177	2.0%
Unknown / Refused	*	*	*	*	*	*	*	*	*	*
Insurance Status:										
Insured	154,093	90.7%	39,391	88.2%	12,126	89.6%	27,262	89.9%	232,872	90.1%
Uninsured	11,008	6.5%	3,831	8.6%	1,091	8.1%	2,206	7.3%	18,136	7.0%
Unknown / Refused / Missing	4,863	2.9%	1,430	3.2%	316	2.3%	873	2.9%	7,483	2.9%

Source: Office of Health Status Monitoring, Hawaii State Department of Health

Note:

- * Sample numbers provisionally weighted and numbers adjusted (total numbers are adj.)
- * Row and / or column totals may not sum to totals listed due to rounding
- * If sample numerator <50 or sample denominator <50, data are not reliable
- * Sample size 14,839 people

Hawaiian Students' Alcohol, Tobacco, and Other Drug Use - Statewide: 2002

	6th Grade		8th Grade		10th Grade		12th Grade	
	2000	2002	2000	2002	2000	2002	2000	2002
Ever Used Tobacco	17.0%	14.2%	47.8%	37.9%	57.6%	49.7%	68.0%	53.4%
Ever Used Any Cigarettes	16.3%	13.5%	46.5%	37.6%	56.1%	48.7%	66.5%	51.3%
Ever Used Smokless Tobacco	1.8%	1.6%	5.5%	3.1%	7.1%	6.3%	14.1%	10.7%
Ever Used Any Alcohol	29.1%	24.9%	62.7%	54.4%	78.5%	72.6%	82.8%	80.9%
Ever Used Beer or Wine (more than a few sips)	28.3%	24.2%	59.6%	53.2%	75.7%	70.1%	81.1%	77.2%
Ever Used Hard Liquor	6.7%	7.8%	37.2%	34.1%	63.3%	59.4%	75.5%	74.6%
Ever Been Drunk in Lifetime	4.3%	5.4%	27.6%	27.2%	51.2%	49.0%	63.4%	63.3%
Ever Used Marijuana	4.3%	5.0%	25.3%	26.6%	48.6%	48.9%	57.8%	60.2%
Ever Used Cocaine	0.3%	0.4%	2.5%	2.2%	6.1%	3.8%	7.0%	4.0%
Ever Used Inhalants	7.1%	4.9%	10.0%	9.0%	8.3%	10.4%	6.7%	8.6%
Ever Used Methamphetamine	0.3%	0.6%	2.9%	2.0%	6.8%	4.3%	6.2%	5.6%
Ever Used Heroin or Other Opiates	0.5%	0.4%	1.7%	1.0%	1.5%	1.7%	1.7%	1.0%
Ever Used Sedatives or Tranquilizers	0.6%	0.5%	2.8%	2.5%	4.1%	4.4%	2.9%	6.2%
Ever Used Hallucinogens	0.3%	0.6%	4.4%	3.6%	7.0%	6.0%	9.4%	9.4%
Ever Used Steroids	2.8%	2.5%	3.1%	3.1%	3.1%	4.5%	3.8%	3.4%
Ever Used Ecstasy/MDMA	0.3%	0.1%	3.5%	4.2%	8.1%	8.9%	9.6%	11.3%
Ever Used GHB	0.0%	0.2%	0.0%	1.7%	0.0%	2.5%	0.0%	3.1%
Ever Used Rohypnol	0.0%	0.4%	0.0%	1.2%	0.0%	1.2%	0.0%	0.7%
Ever Used Ketamine	0.0%	0.3%	0.0%	0.6%	0.0%	0.6%	0.0%	1.8%

Source: Alcohol and Drug Abuse Division, State of Hawai'i Department of Health, "The 2002 Tobacco, Alcohol, and Other Drug Use Study, Adolescent Prevention and Treatment Needs Assessment - Hawaiian Students."

**Antisocial Behaviors - Hawaiian Students' Own Antisocial Behaviors
in the Past 12 Months - Statewide: 2002**

	6th Grade		8th Grade		10th Grade		12th Grade	
	2000	2002	2000	2002	2000	2002	2000	2002
Been suspended from school?	7.2%	6.8%	15.4%	17.4%	13.0%	10.3%	10.0%	9.3%
Been drunk or high at school?	2.9%	3.0%	16.4%	19.2%	25.8%	25.9%	28.1%	26.0%
Sold illegal drugs?	1.1%	0.9%	7.9%	5.5%	10.4%	11.9%	10.7%	13.8%
Stolen or tried to steal a vehicle?	1.5%	1.3%	4.8%	4.4%	5.3%	6.6%	3.3%	3.8%
Been arrested?	1.9%	2.5%	9.0%	7.7%	8.0%	8.2%	6.5%	5.9%
Attacked someone with intention to harm?	6.5%	11.3%	13.3%	15.8%	12.4%	13.8%	10.3%	13.9%
Carried a handgun?	1.9%	1.8%	5.3%	3.8%	4.3%	3.6%	2.4%	4.0%
Taken a handgun to school?	1.0%	0.4%	2.8%	0.7%	1.7%	0.6%	0.7%	1.0%

*Source: Alcohol and Drug Abuse Division, State of Hawai'i Department of Health,
"The 2002 Tobacco, Alcohol, and Other Drug Use Study.
Adolescent Prevention and Treatment Needs Assessment - Hawaiian Students."*

HEALTH RESOURCES

VARIOUS HEALTH SERVICES

Community Clinic of Maui

48 Lono Avenue
Kahului, HI 96732
Phone: (808) 871-7772
Fax: (808) 872-4029

Hāna Community Health Center

4590 Hāna Highway
Hāna, HI 96713
Phone: (808) 248-8294
Fax: (808) 248-7223

Hui Mālama Ola Nā 'Ōiwi

311 Kalaniana'ole Avenue
Hilo, HI 96720
Phone: (808) 969-9220
Fax: (808) 961-4794

Hāmākua Health Center
45-549 Plumeria Street
Honoka'a, HI 96727
Phone: (808) 775-7206
Fax: (808) 775-9404
Website: www.hamakua-health.org

Bay Clinic, Inc.
311 Kalaniana'ole Avenue
Hilo, HI 96720
Phone: (808) 969-1427
Fax: (808) 961-4795

Ka'ū Family Health Center
95-5583 Mamalahoa Highway
Nā'ālehu, HI 96772
Phone: (808) 929-7311
Fax: (808) 929-9087

Kea'au Family Health Center
16-192 Pili Mua Street
Kea'au, HI 96749
Phone: (808) 930-0400
Fax: (808) 966-4028

Pāhoa Family Health Center
15-2866 Pāhoa Village Road
Pāhoa, HI 96778
Phone: (808) 965-9711
Fax: (808) 965-6240

Hui No Ke Ola Pono

95 Mahani Street
Wailuku, HI 96793
Phone: (808) 244-4647
Fax: (808) 242-6676

Ka Hale a ke Ola Resource Center
670-A Wai'ale Drive
Wailuku, HI 96793

Lahaina Comprehensive Health Center
1830 Honoapi'ilani Highway
Lahaina, HI 96761

Kalihi Palama Health Center

915 North King Street
Honolulu, HI 96817
Phone: (808) 848-1438
Fax: (808) 841-1265
Website: www.healthhawaii.org

Kaua'i Community Health Center

(various locations)
P.O. Box 3990
Lihu'e, HI 96766
Phone: (808) 240-0100

Ho'ōla Lāhui Hawai'i
4491 Rice Street, Suite 6
Lihu'e, HI 96766
Phone: (808) 246-9551
Fax: (808) 246-9551

KCHC – East
4800 Kawaihau Road
Kapa'a, HI 96746
Phone: (808) 822-9298

KCHC – West
4643-B Waimea Canyon Drive
Waimea, HI 96796
Phone: (808) 338-1606

Ke Ola Mamo

1505 Dillingham Boulevard, Room 205
Honolulu, HI 96817
Phone: (808) 848-8000
Fax: (808) 848-8001
Website: keolamamo.org/index.cfm

Ko'olaupoko District
Kahuku Hospital
56-114 Pualalea Street

Kahuku, HI 96717

St. Matthew's Church
41-054 'Ehukai Street
P.O. Box 0741
Waimānalo, HI 96795

Honolulu
Lei Ānuenu HIV/AIDS Education and
Prevention Program
1108 Fort Street Mall, Room 3
Honolulu, HI 96813

**Kōkua Kalihi Valley
Comprehensive Family Services**

2239 North School Street
Honolulu, HI 96819
Phone: (808) 791-9400
Fax: (808) 845-9036
Website: www.kkv.net

Nā Pu'uwai

P.O. Box 130
Kaunakakai, HI 96748
Phone: (808) 553-3653
Fax: (808) 553-3385
Website: www.aloha.net/~aku/page2.html

Moloka'i
Moloka'i General Hospital
P.O. Box 408
Kaunakakai, HI 96748
Phone: (808) 533-5331
Website: www.queens.org/qhs/mgh.htm

Lāna'i
Nā Pu'uwai ke Ola Hou o Lāna'i
P.O. Box 713
Lāna'i City, HI 96763
Phone: (808) 565-7204
Fax: (808) 553-3385

Papa Ola Lōkahi

894 Queen Street
Honolulu, HI 96813
Phone: (808) 597-6550
Fax: (808) 597-6551
Website: papaolalokahi.org

**Queen Emma Clinic
at the Queens Medical Center**

1301 Punchbowl Street
Honolulu, HI 96813

Phone: (808) 547-4582
Website: www.queens.org

Wai'anae Coast Comprehensive Health Center

86-260 Farrington Highway
Wai'anae, HI 96792
Phone: (808) 696-7081
Fax: (808) 696-7093
Website: www.wcchc.com

Waikiki Health Center

277 'Ōhūa Avenue
Honolulu, HI 96815
Phone: (808) 922-4787
Fax: (808) 922-4794
Website: www.waikikihealthcenter.org

Waimānalo Health Center

41-1347 Kalaniana'ole Highway
Waimānalo, HI 96795
Phone: (808) 259-7948
Fax: (808) 259-0335
Website: www.waimanalohc.org

ELDERLY CARE

Adult & Community Care Services Branch

810 Richards Street, Suite 400
Honolulu, HI 96813
Phone: (808) 586-5701
Fax: (808) 586-5700

Lunalilo Home

501 Kekauluohi Street
Honolulu, HI 96825
Phone: (808) 395-1000

SUBSTANCE ABUSE SERVICES

Hale Na'auau Pono

86-226 Farrington Highway
Wai'anae, HI 96792
Phone: (808) 696-4211
Fax: (808) 696-5516
Website: www.wccmhc.org

Hina Mauka

45-845 Po'okela Street
Kane'ohe, HI 96744
Phone: (808) 236-2600

Fax: (808) 236-2626
Website: www.hinamauka.org

Ho'omau ke Ola

85-761 Farrington Highway, Suite 101
Wai'anae, HI 96792
Phone: (808) 696-4266

**Mālama Family Recovery Center-
Mālama Nā Mākua a Keiki**

388 Ano Street
Kahului, HI 96732
Phone: (808) 877-7117
Fax: (808) 877-7120

Salvation Army - Pūlama Nā Wahine Ola Hou

845 22nd Avenue
Honolulu, HI 96816
Phone: (808) 732-2802
Fax: (808) 734-7470
Website: www.salvationarmyhawaii.org

**Waianae Coast Comprehensive Health Center /
Mālama Recovery**

89-188 Farrington Highway
Wai'anae, HI 96792
Phone: (808) 668-2277

Phone: (808) 589-1149
Fax: (808) 589-1160

Kahului Clinic

140 Ho'ohana Street
Kahului, HI 96732
Phone: (808) 871-1176
Fax: (808) 871-1131

Kailua-Kina Clinic

75-184 Hualālai Road, No. 205
Kailua-Kona, HI 96740
Phone: (808) 329-8211
Fax: (808) 329-8222

Salvation Army Medical Clinic

75-5759 Kuakini Highway, Suite 101
Kailua-Kona, HI 96740
Phone: (808) 326-5629
Fax: (808) 326-9079

MISCELLANEOUS HEALTH SERVICES

Community Learning Center at Nānākuli

87-2070 C Farrington Highway
Wai'anae, HI 96792
Phone: (808) 668-1517

Mobile Health Care Project

140 B Holomua Street
Hilo, HI 96720
Phone: (808) 935-3050
Fax: (808) 935-3794

**Planned Parenthood of Hawai'i
(various locations)**

Main office
1340 South King Street, No. 309
Honolulu, HI 96814
Phone: (808) 589-1156
Fax: (808) 589-1404

Honolulu Clinic
1350 South King Street, No. 310
Honolulu, HI 96814

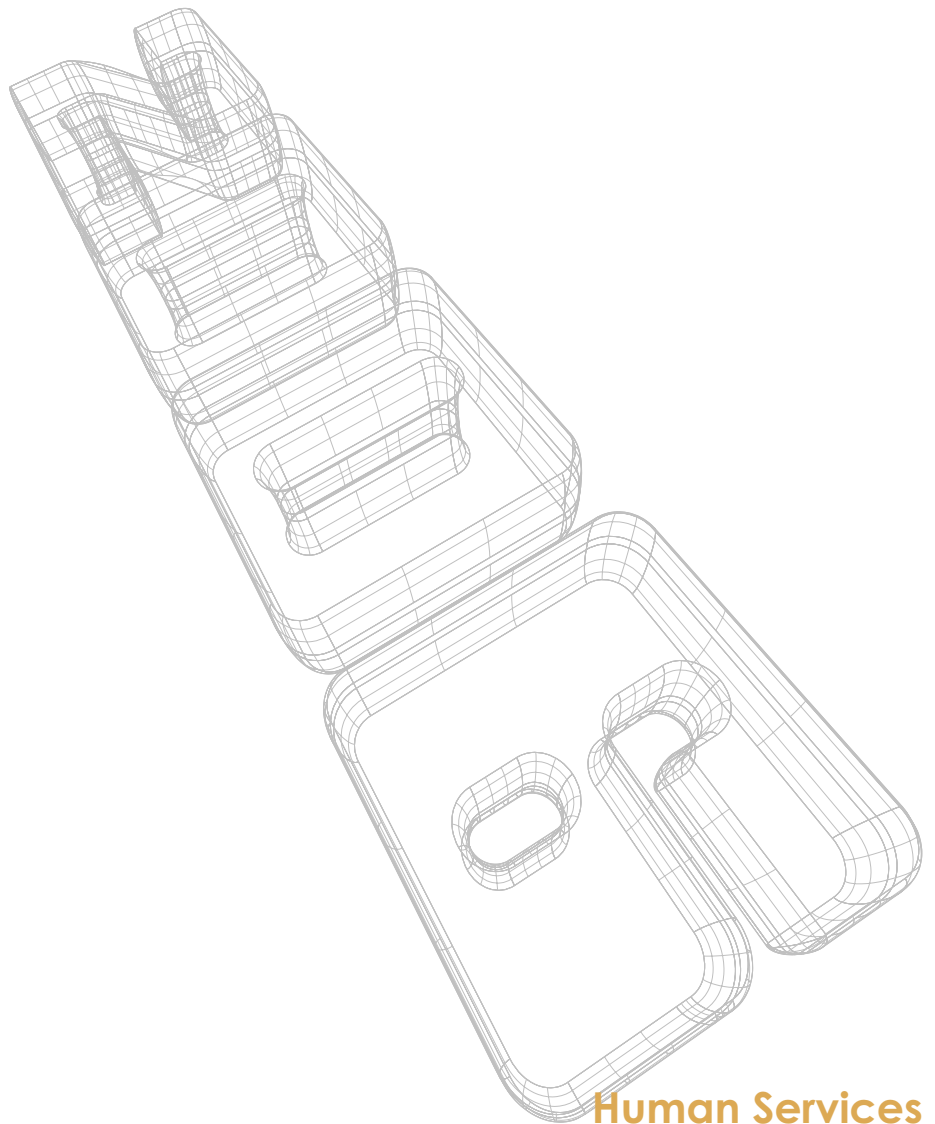

Human Services

HUMAN SERVICES

Thanks in large part to social service programs that began to be implemented over 20 years ago, Native Hawaiians as a group have made significant strides in improving their health and welfare. The benefits and services of these programs have provided many with access to resources that have bootstrapped them into the mainstream. However, what remains problematic is that a disproportionately large percentage of Hawaiians still lack access to resources that can meet basic needs such as food, shelter, primary health care, employment and training, and safety.

Central to the problem of accessing resources is the fact that too many Hawaiians remain impoverished. Statistics from data indexes relating to income, employment, and public assistance show that Native Hawaiians still rank among the highest in negative social indicators. Native Hawaiians are among those with the lowest median incomes, highest unemployment rates, and highest dependence on government assistance programs such as TANF. What is very disturbing is that Hawaiians represent the highest percentage of homeless in Hawaii, a fact that has prompted the phrase, “homeless in their own land.”

Unfortunately, poverty contributes to other problems that afflict Hawaiians. It often breeds despair, feelings of hopelessness, and desperation, human emotions that can trigger severe social deviance such as domestic violence, substance and alcohol abuse, and criminal activity. Again, the statistics reveal that Hawaiians are overrepresented on indexes relating to crime and other forms of anti-social behavior.

For social service organizations and agencies in Hawaii, the statistics provide justification that, while some gains have been made in bettering the conditions of Native Hawaiians over the past 20 years, much more needs to be done to specifically improve their access to resources that meet basic needs and generally, to root out the systemic causes of poverty.

Poverty Status in 1999: Statewide

	Number	Percent
Native Hawaiian-headed families	6,565	14.1
With related children under 18 years	5,720	18.3
With related children under 5 years	not computed	not computed
Native Hawaiian-headed families with female householder, no husband present	3,750	31.3
With related children under 18 years	3,450	39.1
With related children under 5 years	not computed	not computed
Native Hawaiian individuals	38,005	16.0
18 years and older	20,065	13.7
65 years and older	1,325	9.1
Related children under 18 years	17,480	19.3
Related children 5 to 17 years	12,325	18.4
Unrelated individuals 15 years and older	8,725	61.3

Source: Kamehameha Schools, Aloha Counts: Census 2000 Special Tabulations for Native Hawaiians.

Poverty Status in 1999: Island of Hawai'i

	Number	Percent
Native Hawaiian-headed families	1,495	17.4
With related children under 18 years	1,330	22.5
With related children under 5 years	not computed	not computed
Native Hawaiian-headed families with female householder, no husband present	835	36.6
With related children under 18 years	785	44.4
With related children under 5 years	not computed	not computed
Native Hawaiian individuals	8,950	21.1
18 years and older	4,430	17.6
65 years and older	194	8.7
Related children under 18 years	4,385	25.6
Related children 5 to 17 years	3,230	24.8
Unrelated individuals 15 years and older	1,969	71.0

Source: Kamehameha Schools, Aloha Counts: Census 2000 Special Tabulations for Native Hawaiians.

Poverty Status in 1999: Island of Kauaʻi

	Number	Percent
Native Hawaiian-headed families	410	15.9
With related children under 18 years	380	20.4
With related children under 5 years	not computed	not computed
Native Hawaiian-headed families with female householder, no husband present	210	36.5
With related children under 18 years	195	42.4
With related children under 5 years	not computed	not computed
Native Hawaiian individuals	2,205	17.0
18 years and older	1,030	13.7
65 years and older	80	12.3
Related children under 18 years	1,165	21.4
Related children 5 to 17 years	874	21.5
Unrelated individuals 15 years and older	305	46.9

Source: Kamehameha Schools, Aloha Counts: Census 2000 Special Tabulations for Native Hawaiians.

Poverty Status in 1999: Island of Lānaʻi

	Number	Percent
Native Hawaiian-headed families	30	20.7
With related children under 18 years	20	20.0
With related children under 5 years	not computed	not computed
Native Hawaiian-headed families with female householder, no husband present	15	33.3
With related children under 18 years	15	33.3
With related children under 5 years	not computed	not computed
Native Hawaiian individuals	95	13.0
18 years and older	50	12.0
65 years and older	10	25.0
Related children under 18 years	45	14.3
Related children 5 to 17 years	20	10.5
Unrelated individuals 15 years and older	10	28.6

Source: Kamehameha Schools, Aloha Counts: Census 2000 Special Tabulations for Native Hawaiians.

Poverty Status in 1999: Island of Maui

	Number	Percent
Native Hawaiian-headed families	535	11.2
With related children under 18 years	450	13.3
With related children under 5 years	not computed	not computed
Native Hawaiian-headed families with female householder, no husband present	335	30.7
With related children under 18 years	280	35.7
With related children under 5 years	not computed	not computed
Native Hawaiian individuals	3,100	12.6
18 years and older	1,775	12.0
65 years and older	144	12.2
Related children under 18 years	1,320	13.6
Related children 5 to 17 years	835	11.8
Unrelated individuals 15 years and older	895	50.4

Source: Kamehameha Schools, Aloha Counts: Census 2000 Special Tabulations for Native Hawaiians.

Poverty Status in 1999: Island of Moloka'i

	Number	Percent
Native Hawaiian-headed families	215	23.1
With related children under 18 years	190	28.6
With related children under 5 years	not computed	not computed
Native Hawaiian-headed families with female householder, no husband present	65	30.2
With related children under 18 years	65	41.9
With related children under 5 years	not computed	not computed
Native Hawaiian individuals	1,200	27.3
18 years and older	545	21.5
65 years and older	40	13.6
Related children under 18 years	635	34.4
Related children 5 to 17 years	400	28.8
Unrelated individuals 15 years and older	190	84.4

Source: Kamehameha Schools, Aloha Counts: Census 2000 Special Tabulations for Native Hawaiians.

Poverty Status in 1999: Island of O'ahu

	Number	Percent
Native Hawaiian-headed families	3,890	13.1
With related children under 18 years	3,365	17.4
With related children under 5 years	not computed	not computed
Native Hawaiian-headed families with female householder, no husband present	2,288	29.5
With related children under 18 years	2,098	37.6
With related children under 5 years	not computed	not computed
Native Hawaiian individuals	22,385	14.8
18 years and older	12,165	12.8
65 years and older	845	8.3
Related children under 18 years	9,920	17.7
Related children 5 to 17 years	6,980	17.0
Unrelated individuals 15 years and older	5,295	60.5

Source: Kamehameha Schools, Aloha Counts: Census 2000 Special Tabulations for Native Hawaiians.

Number and Percent Uninsured by County and Ethnicity - Population of Hawai'i, Hawai'i Health Survey (HHS) 2002

Ethnicity	C & C of Hon		Hawai'i		Kauai		Maui		Total	
	#	%	#	%	#	%	#	%	#	%
Caucasian	6,558	3.5%	4,064	8.8%	1,699	9.8%	4,785	10.9%	17,106	5.8%
Hawaiian	7,739	4.9%	3,159	7.7%	951	7.6%	2,458	7.3%	14,307	5.8%
Chinese	1,463	2.3%	*	*	92	9.4%	163	3.6%	1,869	2.7%
Filipino	6,477	4.1%	652	3.6%	782	5.3%	1,086	4.6%	8,997	4.2%
Japanese	4,728	2.6%	602	2.2%	135	1.5%	462	2.5%	5,927	2.5%
Other										
Unknown	4,472	4.4%	1,986	11.3%	701	15.6%	1,240	10.3%	8,399	6.2%
Refused										

Source: Hawai'i Department of Health, Hawai'i Health Survey (HHS), Office of Health Status Monitoring

Note:

* Sample numbers provisionally weighted and adjusted for total population of Hawai'i (total numbers are adjusted as households without telephones, Ni'ihau, group quarters, and homeless are not represented, see HHS Procedure Manual 2002)

* Row and/or column totals may not sum to totals listed due to rounding

**Ethnicity of Individuals Served by TANF / TANOF Programs -
State of Hawai'i: FY 2002**

Ethnicity	Percentage
Other Pacific Islander	7%
Hawaiian / Part Hawaiian	32%
Caucasian	15%
Filipino	9%
Samoan	8%
Asian	6%
Other	23%

Source: State of Hawai'i Department of Human Services, "Report on Fiscal Year 2002."

**Composition of TANF / TANOF Households -
State of Hawai'i : FY 2002**

Household Composition	Percentage
No Eligible Adult and 1 Child	9%
No Eligible Adult and 2 Children	3%
No Eligible Adult and 3 or More Children	3%
1 Adult and 0 Children	1%
1 Adult and 1 Child	27%
1 Adult and 2 Children	17%
1 Adult and 3 Children	9%
1 Adult and 4 or More Children	7%
2 Adults and 1 Child	7%
2 Adults and 2 Children	7%
2 Adults and 3 Children	5%
2 Adults and 4 or More Children	3%

Source: State of Hawai'i Department of Human Services, "Report on Fiscal Year 2002."

Heads of Households of TANF / TANOF Families - State of Hawai'i: FY 2002

Heads of Households	Percentage
Female	74%
Male	26%
Under 35 Years Old	62%
Never Married	42%
Married	26%
Common Law	8%
Separated or Divorced	24%
Head of Household Disabled	32%
Head of Household with Grade 12 or Higher Education	62%

Source: State of Hawai'i Department of Human Services, "Report on Fiscal Year 2002."

Ethnic Distribution of Employment and Training Clients - State of Hawai'i: FY 2002

Ethnicity	Percentage
Part Hawaiian	36.79%
Caucasian	28.13%
Filipino	10.15%
Samoan	2.78%
Asian, African American, Hispanic	13.04%
Other	9.11%

Source: State of Hawai'i Department of Human Services, "Report on Fiscal Year 2002."

Ethnic Distribution of First-To-Work Clients - State of Hawai'i: FY 2002

Ethnicity	Number	Percentage
Missing Data	19	0.22%
Part Hawaiian	3,774	44.66%
Caucasian	1,242	14.70%
Filipino	1,128	13.35%
Samoaan	651	7.70%
Asian, African American, Hispanic	903	10.69%
Other	752	8.90%
TOTAL	8,450	100%

Source: State of Hawai'i Department of Human Services, "Report on Fiscal Year 2002."

Ethnicity of Individuals Served by General Assistance Program - State of Hawaii: FY 2002

Ethnicity	Percentage
Caucasian	39.1%
Hawaiian / Part Hawaiian	29.2%
Chinese	1.5%
Filipino	8.3%
Japanese	5.8%
Black	3.6%
Other Asian	2.0%
Hispanic	0.2%
Samoan	1.9%
Korean	1.3%
Other Pacific Islanders	3.2%
Others	3.9%

Source: State of Hawaii Department of Human Services, "Report on Fiscal Year 2002."

Typical Characteristics of Individuals Served by General Assistance Program - State of Hawai'i: FY 2002

Characteristics of Individuals	Percentage
<i>Age of Head of Household</i>	
29 Years or Younger	20.7%
Between 30 and 39 Years	25.5%
Between 40 and 49 Years	32.0%
Between 50 and 59 Years	18.3%
60 Years and Older	3.5%
<i>Marital Status of Head of Household</i>	
Single	56.5%
<i>Gender of Head of Household</i>	
Male	60.3%
Female	39.7%

Source: State of Hawai'i Department of Human Services, "Report on Fiscal Year 2002."

HUMAN SERVICES RESOURCES

MULTI-SERVICE PROGRAMS

Aloha United Way

200 North Vineyard Blvd., Suite 700
Honolulu, HI 96817
Phone: (808) 536-1951
Website: www.auw.org

Alu Like Inc.

Kūlia Like Program (various locations)

O'ahu

Hale o nā Limahana
458 Keawe Street
Honolulu, HI 96813
Phone: (808) 535-6720 or (808) 535-6721

Hawai'i

32 Kino'ole Street, #102
P.O. Box 606
Hilo, HI 96720
Phone: (808) 961-2625

Maui

1977 Ka'ohu Street
Wailuku, HI 96793
Phone: (808) 242-9774

Kaua'i

Lihu'e Town Center
3100 Kūhi'o Hwy. Rm C6-C7
Lihu'e, HI 96766
Phone: (808) 245-8545

Moloka'i

Kūlana 'Ōiwi Multi-Cultural Center
Maunaloa Highway, Kalama'ula Bldg D.
P.O. Box 1859
Kaunakakai, HI 96748
Phone: (808) 553-5393

Lāna'i

730 Lāna'i Avenue, Suite 108
P.O. Box 630667
Lāna'i City, HI 96763
Phone: (808) 565-6043

Hale Kipa

615 Pi'ikoi Street, Suite 203
Honolulu, HI 96814

Phone: (808) 589-1829
Fax: (808) 589-2610
Website: www.halekipa.org

Pacific Gateway Center

720 North King Street
Honolulu, HI 96817
Phone: (808) 845-3918
Fax: (808) 842-1962
Website: www.pacificgateway.org

Queen Lili'uokalani Children's Center

1300 Hālonā Street
Honolulu, HI 96817
Phone: (808) 847-1302
Fax: (808) 841-0502
Website: www.qlcc.org

Salvation Army

2950 Mānoa Road
Honolulu, HI 96822
Phone: (808) 988-2136
Fax: (808) 988-1508
Website: www.salvationarmyhawaii.org

EARLY CHILDHOOD DEVELOPMENT

Alu Like Inc. (various locations and programs)

Ho'owaiwai nā Kamali'i – Native Hawaiian Early
Childhood Consortium
King's Gate Plaza
555 North King Street, Suite 105
Honolulu, HI 96813
Phone: (808) 845-0275

Native Hawaiian Child Care Assistance Project
Hale o nā Limahana
458 Keawe Street
Honolulu, HI 96813
Phone: (808) 535-1300

Pulama I Nā Keiki (various locations)

Kaua'i
Lihu'e Office
Lihu'e Town Center
3100 Kūhiō Highway, Suite C-3
Lihu'e, HI 96766
Phone: (808) 245-8859

O'ahu
Honolulu Office
King's Gate Plaza
555 North King Street, Suite 104
Honolulu, HI 96813
Phone: (808) 843-1417

Leeward Office
Campbell Square, Kapolei Building
1001 Kamōkila Blvd., Suite 105
Kapolei, HI 96744
Phone: (808) 674-8409

Windward Office
Windward City Shopping Center
45-480 Kāne'ohe Bay Drive, Unit C-9
Kāne'ohe, HI 96744
Phone: (808) 235-6559

Moloka'i
Kaunakakai Office
P.O. Box 870
Kaunakakai, HI 96748
Phone: (808) 553-3284

Maui
Wailuku Office
1498 B-2 Lower Main Street
Wailuku, HI 96793
Phone: (808) 244-8849

Hāna Office
4535 A Hāna Highway
Hāna, HI 96713
Phone: (808) 248-7521

Hawai'i
Kona Office
74-5615 Luhia Street, D-2
Kailua-Kona, HI 96740
Phone: (808) 329-4801

Waimea Office
Kamuela Business Center
64-1032 Māmalahoa Highway
Phone: (808) 885-7040

Hilo Office
42 Kino'ole Street
Hilo, HI 96720
Phone: (808) 934-9180

HIGH RISK REDUCTION

Alu Like Inc. (various locations and programs)

Hui Kū 'Ōpio o ke Ko'olau Project
47-388 Hui 'Iwa Street #27
Kāne'ohe, HI 96744
Phone: (808) 239-5614

Ke Ala Ho'olōkahi Project (The Path of Harmony)
89-137 Nānākuli Avenue
Nānākuli, HI 96792
Phone: (808) 668-0555

Moloka'i Community Service Council
Kūlana 'Ōiwi Multi-Cultural Center
Maunaloa Highway, Kalama'ula Bldg D
P.O. Box 1859
Kaunakakai, HI 96748
Phone: (808) 553-5393

Youth Alcohol, Tobacco and other Drugs Prevention Project

Hawai'i
81-6627 Māmalahoa Highway, #105
Kealahou, HI 96750
Phone: (808) 323-2804
Toll free phone: 1-800-306-4449

Maui
4535-A Hāna Highway
Hāna, HI 96713
Phone: (808) 248-7286

Kaua'i
Lihu'e Town Center
3100 Kūhiō Highway, Room C6 & C7
Lihu'e, HI 96766
Phone: (808) 245-8545

Moloka'i
Kūlana 'Ōiwi Multi-Cultural Center
Maunaloa Highway, Kalama'ula Bldg D.
P.O. Box 1859
Kaunakakai, HI 96748
Phone: (808) 553-5393

LEGAL

Native Hawaiian Legal Corporation

1164 Bishop Street, Suite 1205
Honolulu, HI 96813-2817
Phone: (808) 521-2302
Fax: (808) 537-4268

Legal Aid Society of Hawai'i

924 Bethel Street
Honolulu, HI 96813
Phone: (808) 536-4302
Fax: (808) 527-8088
Hotline: (808) 536-4302
Toll free phone: (800) 499-4302
Website: <http://www.legalaidhawaii.org>

Volunteer Legal Services Hawai'i

545 Queen Street, Suite 906
Honolulu, HI 96813
Phone: (808) 528-7046
Fax: (808) 524-2147
Website: <http://www.vlsh.org>

HAWAIIAN ADVOCACY

Council for Native Hawaiian Advancement

33 South King Street, Suite 513
Honolulu, HI 96813
Phone: (808) 521-5011
Fax: (808) 521-4111
Toll Free: (800) 709-2642
Toll Free Fax: (800) 710-2642
Website: <http://www.hawaiiancouncil.org>

Hawaii Maoli

P.O. Box 1135
Honolulu, HI 96807
Phone: (808) 394-0050

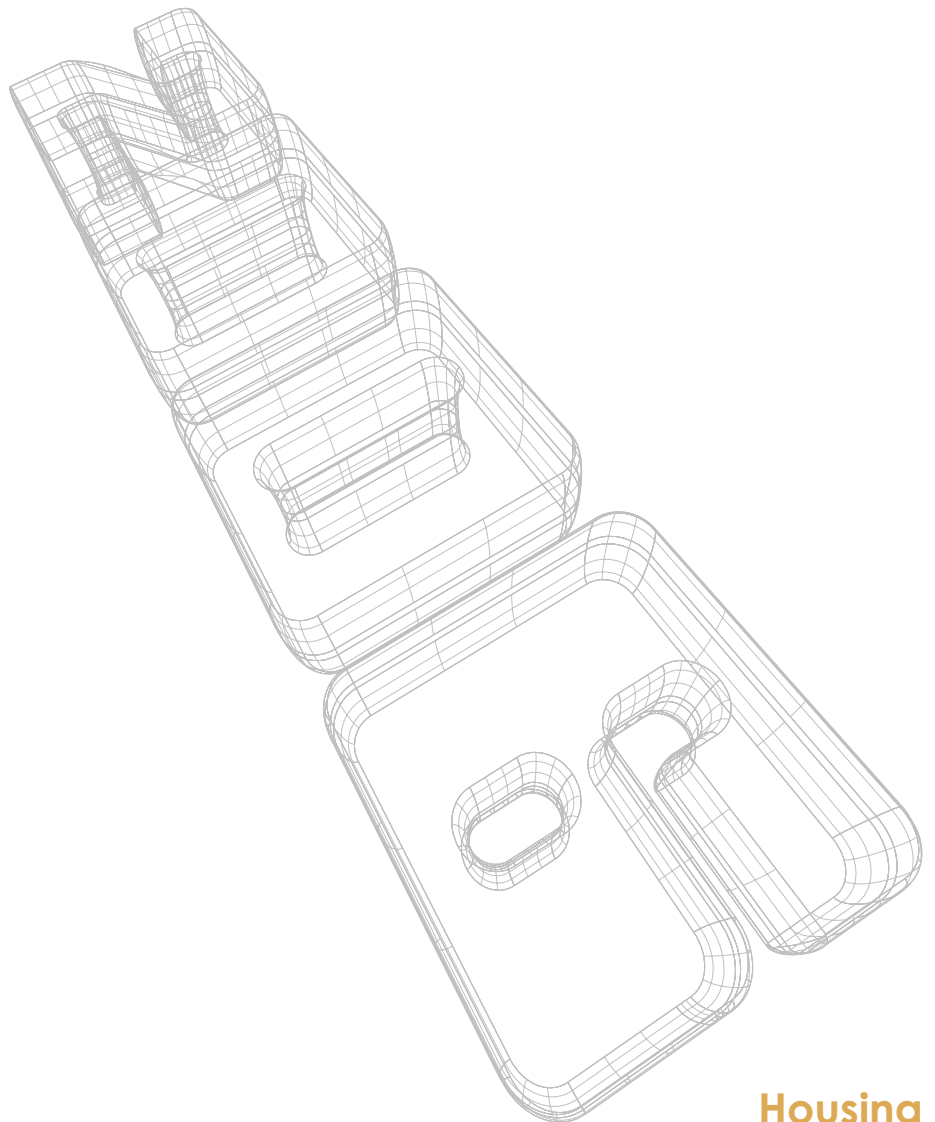

Housing

HOUSING

Prior to western influence, Hawaiians lived in an ahupua'a or political subdivision that contained virtually all the resources to sustain life. Carefully managed by chiefs appointed by the ali'i, these pie-shaped tracts from the sea to the mountains provided resources such as wood for housing and fishponds and plants for food. Hawaiian families thrived among a careful balance of land control, conservation and shared responsibility.

During the 19th Century, the elimination of ahupua'a subdivisions and conversion of land ownership from royalty to individuals, resulted in the permanent displacement of Hawaiians from their traditional homes. Ultimately, few Hawaiians were recipients of lands under the Great Māhele or subsequent Kūleana Land Grant Acts.

With the proliferation of substandard housing conditions for Hawaiians, the United State Congress was compelled to enact the Hawaiian Homes Commission Act in 1920 as an attempt to enable native Hawaiians to obtain long term land leases in a manner to preserve Hawaiian values, traditions, and culture. However, the Act defined "native Hawaiian" as any descendant of not less than one-half part of the blood of the races inhabiting the Hawaiian Islands previous to 1778 – greatly limiting the number of Hawaiians who might lease land under this legislation. Furthermore, there is significant evidence that obtaining mortgages is a barrier for native Hawaiians to receive a homestead lease.

Native Hawaiians with less than 50% blood quantum are limited to seeking housing based on current market values. With rapidly spiraling housing costs and median income significantly lower than the state average, Native Hawaiians are unable to afford homes in the open rental and residential market and suffer higher risk of homelessness, overcrowding, and transient housing. The result is that the lack of affordable housing has severely compromised the quality of life for many Native Hawaiians.

Household Size and Type: Hawai'i Health Survey, 2003

Household Type and Size	County									
	Honolulu		Hawai'i		Kaua'i		Maui		Total	
	Number	Percent	Number	Percent	Number	Percent	Number	Percent	Number	Percent
	STATEWIDE									
Household Type										
One Adult No Kids	47,145	5.4%	10,649	6.9%	3,691	6.2%	7,744	5.8%	69,229	5.7%
Adults No Kids	322,134	36.9%	59,255	38.3%	22,657	37.8%	48,545	36.2%	452,590	37.0%
One Adult with Kids	19,201	2.2%	6,950	4.5%	2,045	3.4%	5,851	4.4%	34,048	2.8%
Adults with Kids	485,227	55.5%	77,671	50.3%	31,557	52.6%	71,959	53.7%	666,414	54.5%
Household Size										
1	47,145	5.4%	10,649	6.9%	3,691	6.2%	7,744	5.8%	69,229	5.7%
2	171,838	19.7%	38,637	25.0%	13,864	23.1%	33,426	24.9%	257,764	21.1%
3	158,213	18.1%	28,397	18.4%	11,301	18.9%	26,614	19.8%	224,525	18.4%
4	197,691	22.6%	33,571	21.7%	12,940	21.6%	29,861	22.3%	274,063	22.4%
5	132,412	15.2%	19,177	12.4%	10,058	16.8%	19,912	14.8%	181,558	14.9%
6	74,353	8.5%	11,872	7.7%	4,009	6.7%	6,856	5.1%	97,091	7.9%
7	35,618	4.1%	5,458	3.5%	1,666	2.8%	5,791	4.3%	48,553	4.0%
8+	56,436	6.5%	6,765	4.4%	2,422	4.0%	3,894	2.9%	69,518	5.7%

Household Size and Type: Hawai'i Health Survey, 2003 - Continued

Household Type and Size	County									
	Honolulu		Hawai'i		Kaua'i		Maui		Total	
	Number	Percent	Number	Percent	Number	Percent	Number	Percent	Number	Percent
NATIVE HAWAIIAN										
Household Type										
One Adult No Kids	6,109	3.6%	1,141	2.6%	245	1.8%	776	2.6%	8,271	3.2%
Adults No Kids	42,857	25.2%	10,326	23.1%	2,779	20.5%	6,205	20.5%	62,166	24.0%
One Adult with Kids	5,302	3.1%	2,248	5.0%	541	4.0%	1,861	6.1%	9,952	3.9%
Adults with Kids	115,697	68.1%	30,937	69.3%	9,967	73.7%	21,499	70.9%	178,101	68.9%
Household Size										
1	6,109	3.6%	1,141	2.6%	245	1.8%	776	2.6%	8,271	3.2%
2	18,468	10.9%	5,715	12.8%	1,631	12.1%	3,382	11.1%	29,196	11.3%
3	26,439	15.6%	7,066	15.8%	1,851	13.7%	5,082	16.7%	40,438	15.6%
4	34,598	20.4%	10,337	23.2%	3,035	22.4%	8,077	26.6%	56,047	21.7%
5	35,434	20.8%	8,487	19.0%	3,261	24.1%	7,337	24.2%	54,520	21.1%
6	18,047	10.6%	4,889	10.9%	1,830	13.5%	1,830	6.0%	26,596	10.3%
7	8,894	5.2%	2,709	6.1%	114	0.8%	3,028	10.0%	14,745	5.7%
8+	21,976	12.9%	4,307	9.6%	1,565	11.6%	829	2.7%	28,677	11.1%

Source: Office of Health Status Monitoring, Hawaii State Department of Health

Note:
 * Sample □
 holds without telephones are not represented, see HHS Procedure Manual 2003
 * Row and / or column totals may not sum to totals listed due to rounding
 * If sample numerator <50 or sample denominator <50, data are not reliable
 * Sample size 14,839 people

Department of Hawaiian Home Lands Number of Applicants by County: 2003

Island	Number of Applicants
O'ahu	10,747
Hawai'i	3,978
Maui	2,392
Other	2,200
Kaua'i	1,099
TOTAL	20,416

Source: Department of Hawaiian Home Lands Applicant Survey Report, 2003: SMS Research

Department of Hawaiian Home Lands Home Ownership Rates Among Applicants: 2003

Island	Percentage
Kaua'i	44.9%
Lāna'i	24.9%
Moloka'i	53.4%
Maui	42.1%
O'ahu	50.3%
Hawai'i	64.0%
TOTAL	52.0%

Source: Department of Hawaiian Home Lands Applicant Survey Report, 2003: SMS Research

**Department of Hawaiian Home Lands Applicants' Preference
after Qualifications by Island Preference**

	Hawai'i	O'ahu	Maui	Moloka'i	Lāna'i	Kaua'i	TOTAL
Qualification for Standard Financing							
Not qualified	20.9%	11.5%	15.5%	25.8%	25%	18.4%	16.2%
Low qualifications	39.2%	32.6%	25.9%	35.7%	50%	28.5%	33.6%
Qualified	38%	54.6%	55.3%	35.7%	25%	45%	47.8%
Not enough data	1.9%	1.3%	3.3%	2.9%	-	8%	2.4%
Summary Status and Preference after Qualification							
Turnkey Homes	13.3%	37.2%	24.6%	14.9%	25%	17.5%	25.4%
Turnkey - delayed	12.8%	13.2%	7.3%	10.8%	50%	9.6%	12.2%
Improved Lots	17.1%	13.8%	23.3%	14.0%	-	23.2%	16.8%
Improved Lots - delayed	11.9%	3.6%	9%	12.3%	-	7.1%	7.5%
Rural Lots	3.9%	0.5%	5.4%	1.4%	-	7.1%	2.8%
Rural lots - delayed	3.2%	1.5%	1.2%	-	-	2.4%	2%
Farm/Ranch Only	1.4%	0.2%	1.7%	1.4%	-	2.9%	1.1%
Raw Land	4.3%	2.1%	2.1%	7.1%	-	5.2%	3.3%
Multifamily	6.8%	12.3%	5.1%	5.3%	-	3.3%	8.5%
Commerical	1.4%	1.6%	0.8%	-	-	1.4%	1.3%
Kupuna	2.9%	2.5%	3.8%	6.9%	-	1.9%	2.9%
Not qualified	20.9%	11.5%	15.5%	25.8%	25%	18.4%	16.2%

Source: Department of Hawaiian Home Lands Applicant Survey, 2003; SMS Research

Department of Hawaiian Home Lands Types of Applications by Island of Preference: 2003

	Kaua'i	Lāna'i	Moloka'i	Maui	O'ahu	Hawai'i
Pastoral	156	-	121	209	225	1,164
Agricultural	758	43	315	1,327	16,498	2,737
Residential	1,077	173	649	2,314	7,410	4,628
TOTAL	1,991	216	1,085	3,850	24,133	8,529

Source: Department of Hawaiian Home Lands Applicant Survey Report, 2003: SMS Research

Department of Hawaiian Home Lands Award Preferences of Applicants: 2003

Type of Award	Any Interest	First Choice
Kupuna housing	16.3%	2.9%
Commerical property	18.1%	3.1%
Multifamily unit	38.2%	5.1%
Raw land	29.3%	5.9%
Rural lot	32.5%	8.4%
Improved lot	66.2%	24.6%
Turnkey	79.0%	55.6%

Source: Department of Hawaiian Home Lands Applicant Survey Report, 2003: SMS Research

**Department of Hawaiian Home Lands Applicants Below 80%
HUD Median Income Guidelines: 2003**

Island	Percentage
Lānaʻi	59.0%
Molokaʻi	75.0%
Kauaʻi	62.7%
Hawaiʻi	54.5%
Maui	58.2%
Oʻahu	55.1%
TOTAL	56.2%

*Source: Department of Hawaiian Home Lands Applicant Survey Report, 2003:
SMS Research*

**Department of Hawaiian Homelands Applicants' Location Preferences
- First and Second Choices**

	First Choice		Second Choice	
	Count	Percent	Count	Percent
North Hawai'i	424	2.3%	520	2.9%
Central Hawai'i	1,841	10.1%	1,217	6.7%
West Hawai'i	780	4.3%	939	5.2%
East Hawai'i	2,067	11.3%	1,578	8.7%
South Hawai'i	142	0.8%	87	0.5%
ANYWHERE ON BIG ISLAND	197	1.1%	509	2.8%
O'ahu PUC	1,582	8.7%	1,400	7.7%
East Honolulu, East PUC	81	0.4%	152	0.8%
Windward O'ahu	2,670	14.7%	1,955	10.7%
Moanlua, Pearl City	208	1.1%	379	2.1%
Ewa	1,416	7.8%	1,067	5.9%
Leeward O'ahu	1,022	5.6%	928	5.1%
Central & North Shore O'ahu	309	1.7%	412	2.3%
ANYWHERE ON O'ahu	597	3.3%	387	2.1%
West Maui	179	10%	125	0.7%
Central Maui	487	2.7%	509	2.8%
South Maui	33	0.2%	122	0.7%
Pa'ia, Haiku, Upcountry Maui	914	5.0%	738	4.0%
East Maui	115	0.6%	133	0.7%
ANYWHERE ON MAUI ISLAND	507	2.8%	566	3.1%
Moloka'i	603	3.3%	469	2.6%
Lāna'i	87	0.5%	62	0.3%
North Kaua'i, Kapa'a	573	3.1%	250	1.4%
West Kaua'i	116	0.6%	186	0.1%
East Kaua'i (Lihu'e)	168	0.9%	111	0.6%
South Kaua'i	193	1.1%	91	0.5%
ANYWHERE ON Kaua'i	246	1.4%	303	1.7%
Ni'ihau	-	-	7	-
MAINLAND, NOT IN Hawai'i	-	-	19	0.1%
ANYWHERE, DOESN'T MATTER	321	1.8%	288	1.6%
NO SECOND CHOICE	-	-	1,633	9%
DON'T KNOW	188	1%	604	3.3%
(NO DATA)	148	0.8%	473	2.6%
TOTAL	18,216	100%	18,216	100%

Source: Department of Hawaiian Homelands Applicant Survey Report, 2003: SMS Research

Department of Hawaiian Homelands Qualifications by Island of Residence

	Hawai'i	O'ahu	Maui	Moloka'i	Lāna'i	Kaua'i	TOTAL
Qualification for Standard Financing (%)							
Not qualified	26.1%	11.4%	13.7%	31.8%	25%	22.3%	16.2%
Low qualifications	43.5%	31%	26.1%	38.6%	50%	28.8%	33.6%
Qualified	28.3%	56.2%	55.8%	25%	25%	38.6%	47.8%
Not enough data	2.1%	1.4%	4.4%	4.5%	-	10.3%	2.4%
Number of Applicants							
Not qualified	1,039	1,229	240	148	43	245	2,944
Low qualifications	1,732	3,336	458	180	87	317	6,110
Qualified	1,124	6,036	978	117	43	424	8,722
Not enough data	83	145	76	21	-	113	438

Source: Department of Hawaiian Homelands Applicant Survey Report, 2003: SMS Research

Department of Hawaiian Home Lands Total Number of Applicants by Preference after Qualification

Award Type	Number of Applicants
Turnkey Homes	5,191
Turnkey - delayed	2,496
Improved Lots	3,434
Improved Lots - delayed	1,534
Rural Lots	568
Rural lots - delayed	404
Farm/Ranch Only	217
Raw Land	665
Multifamily	1,725
Commercial	270
Kupuna	597
Assisted Renters	3,316
TOTAL	20,416

Source: Department of Hawaiian Home Lands Applicant Survey, 2003: SMS Research

HOUSING RESOURCES

Department of Hawaiian Home Lands

1099 Alakea Street, Suite 2000
Honolulu, HI 96813
Phone: (808) 586-3840
Fax: (808) 586-3843
Website: www.state.hi.us/dhhl

Honolulu Habitat for Humanity

1136 Union Plaza, Suite 510
Honolulu, HI 96813
Phone: (808) 538-7070
Fax: (808) 538-7171
Website: www.honoluluhabitat.org

State Housing & Community Development Corporation of Hawai'i

677 Queen Street, Suite 300
Honolulu, HI 96813
Phone: (808) 587-0567
Website: www.hcdch.state.hi.us

HOMELESS SERVICES

Institute for Human Services

546 Ka'aahi Street
Honolulu, HI 96817
Phone: (808) 845-7150
Website: www.ihs-hawaii.org

Wai'anae Community Outreach

87-728 Farrington Highway
Wai'anae, HI 96792
Phone: (808) 668-4880
Fax: (808) 668-8257

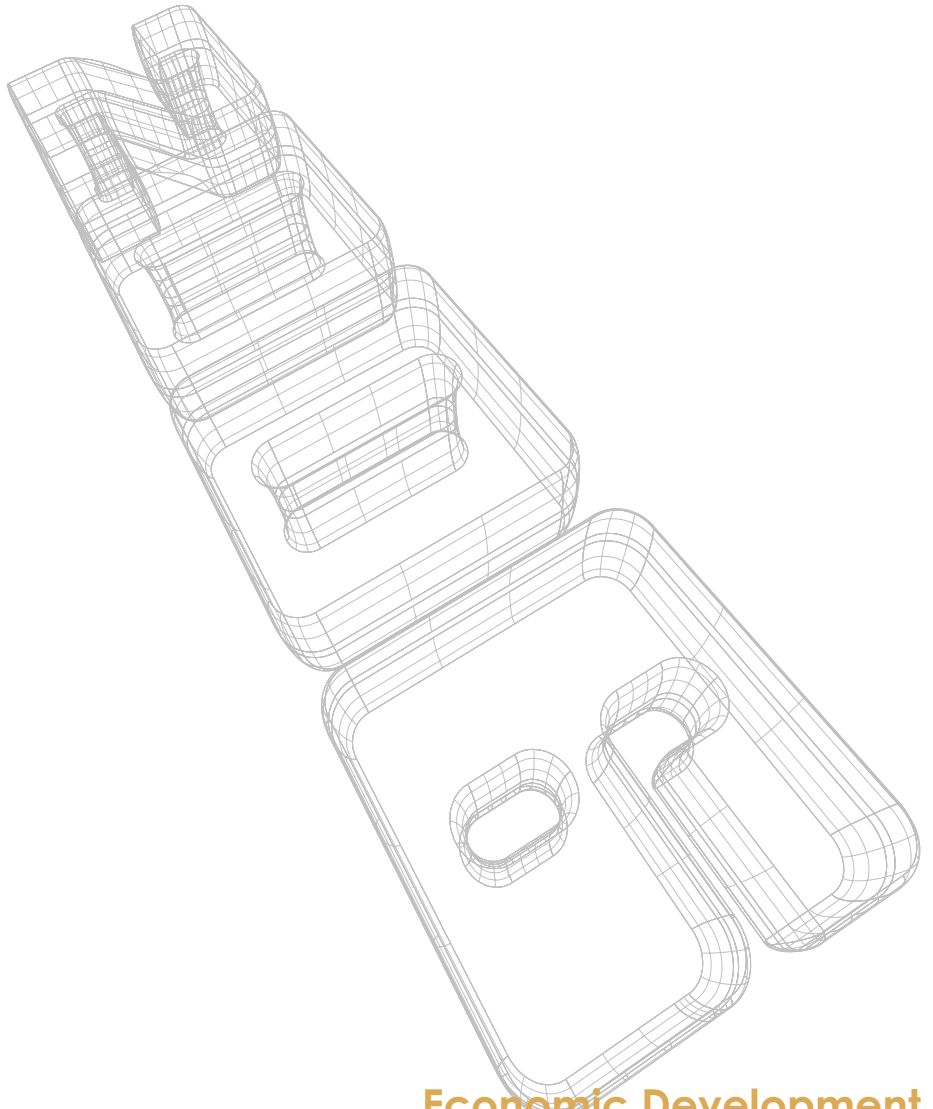

Economic Development

ECONOMIC DEVELOPMENT

Economic development is a broad term that pertains to the creation of jobs and wealth. This is usually associated with improvement in the quality of life on an individual and societal basis. However, Native Hawaiians have had dissimilar quality of life effects from economic development compared to other segments of the population in Hawaii. This section presents indicators of the economic well-being of Native Hawaiians via statistics on employment, household income, and characteristics of Native Hawaiian-owned businesses. Here are some of the highlights:

Native Hawaiian males and females of 16 years and over are nearly 72% and 65%, respectively, in the labor force, which are higher in both cases than the US averages. However, they are more likely to be unemployed; their unemployment rates are higher than the US averages. In addition, Native Hawaiians of ages 25 to 54 years in Hawaii are about 2 percentage points more likely to not be in the workforce compared with their counterparts on the continental US. Higher unemployment level might not be due to the lack of jobs but rather to individuals who are actively seeking employment but lack the necessary education, skills and/or training.

Of the total civilian employment of Native Hawaiians, most are employed in the private sector and are salary workers. The second largest type of employment falls under the category of government workers. There are fewer Native Hawaiians in managerial and professional occupations — only 25% of Native Hawaiians are represented compared with 34% of the US population.

About 62% of Native Hawaiians in Hawaii have household incomes under \$50,000. The Island of Molokai has the largest percentage at 43% of households with incomes under \$24,000 and 75% of all households have incomes under \$50,000. In contrast, the Island of Oahu has the highest percentage of households with incomes over \$50,000 at 49% and closely followed at 48% of total households in the Island of Maui.

A little less than five percent of total Native Hawaiians are self-employed or own their own business. According to the 1997 Economic Census, there are 15,554 Native-Hawaiian-owned firms in the US, out of which 6,600 firms (or 42%) are in Hawaii. A Native Hawaiian-owned firm is usually a one-person operation, with assistance usually provided by family members. Only 2,023 firms (or 13%) out of the total Native Hawaiian-owned firms are with paid employees.

The industry concentration of Native Hawaiian-owned businesses is in the Service industry (44%), followed by Other Industries not classified (18%), the third largest concentration was in Retail (11%), and the fourth largest concentration was in Construction (7%). Breakdown of the Service industry showed that Native Hawaiian-owned Service firms were concentrated in Business services (33%), Engineering, Management, and Accounting (19%), Amusement & Recreation (12%), and Personal services (9%).

Effective approaches to support entrepreneurship and increase the number of Native Hawaiian-owned firms are necessary to increase the wealth of Native Hawaiians.

Comparison of Employment Status for Native Hawaiian and U.S. Populations

Employment Status	Native Hawaiians (percent)	United States (percent)	Difference
Females 16 years and over			
In labor force	64.5	57.5	7
Unemployed	5.7	3.3	2.4
Males 16 years and over			
In labor force	71.5	70.7	0.8
Unemployed	7.0	4.0	3.0

Source: 2000 U.S. Census, Summary File 4, Quick Table DP-3

Native Hawaiian Employment Status: Statewide

	Number	Percent
Native Hawaiian population 16 years and older	158,485	100.0
In labor force	104,415	65.9
Civilian labor force	103,765	65.5
Employed	93,595	59.1
Unemployed	10,170	6.4
Percent of labor force	9.8	N/A
Armed forces	655	0.4
Not in labor force	54,070	34.1
Females 16 years and older	80,620	100.0
In labor force	50,360	62.5
Civilian labor force	50,280	62.4
Employed	45,850	56.9
Own children under 6 years	26,890	100.0
All parents in family in labor force	17,840	66.3
Employed Native Hawaiian civilian population 16 years and older	93,595	100.0

Native Hawaiian Employment Status: Island of Hawai'i

	Number	Percent
Native Hawaiian population 16 years and older	27,635	100.0
In labor force	18,040	65.3
Civilian labor force	18,020	65.2
Employed	15,915	57.6
Unemployed	2,109	7.6
Percent of labor force	11.7	N/A
Armed forces	18	0.1
Not in labor force	9,595	34.7
Females 16 years and older	14,160	100.0
In labor force	8,890	62.8
Civilian labor force	8,885	62.7
Employed	7,880	55.6
Own children under 6 years	4,740	100.0
All parents in family in labor force	2,990	63.1
Employed Native Hawaiian civilian population 16 years and older	15,915	100.0

Source: Kamehameha Schools, Aloha Counts: Census 2000 Special Tabulations for Native Hawaiians.

Native Hawaiian Employment Status: Island of Kaua'i

	Number	Percent
Native Hawaiian population 16 years and older	8,245	100.0
In labor force	5,625	68.2
Civilian labor force	5,625	68.2
Employed	5,165	62.6
Unemployed	460	5.6
Percent of labor force	8.2	N/A
Armed forces	4	0.0
Not in labor force	2,615	31.7
Females 16 years and older	4,060	100.0
In labor force	2,570	63.3
Civilian labor force	2,570	63.3
Employed	2,385	58.7
Own children under 6 years	1,510	100.0
All parents in family in labor force	1,045	69.2
Employed Native Hawaiian civilian population 16 years and older	5,165	100.0

Native Hawaiian Employment Status: Island of Lāna'i

	Number	Percent
Native Hawaiian population 16 years and older	460	100.0
In labor force	310	67.4
Civilian labor force	310	67.4
Employed	305	66.3
Unemployed	4	0.9
Percent of labor force	1.3	N/A
Armed forces	-	0.0
Not in labor force	155	33.7
Females 16 years and older	270	100.0
In labor force	195	72.2
Civilian labor force	195	72.2
Employed	195	72.2
Own children under 6 years	135	100.0
All parents in family in labor force	90	66.7
Employed Native Hawaiian civilian population 16 years and older	305	100.0

Source: Kamehameha Schools, Aloha Counts: Census 2000 Special Tabulations for Native Hawaiians.

Native Hawaiian Employment Status: Island of Maui

	Number	Percent
Native Hawaiian population 16 years and older	15,980	100.0
In labor force	11,250	70.4
Civilian labor force	11,245	70.4
Employed	10,400	65.1
Unemployed	840	5.3
Percent of labor force	7.5	N/A
Armed forces	8	0.1
Not in labor force	4,725	29.6
Females 16 years and older	8,145	100.0
In labor force	5,500	67.5
Civilian labor force	5,500	67.5
Employed	5,155	63.3
Own children under 6 years	3,035	100.0
All parents in family in labor force	2,160	71.2
Employed Native Hawaiian civilian population 16 years and older	10,400	100.0

Native Hawaiian Employment Status: Island of Moloka'i

	Number	Percent
Native Hawaiian population 16 years and older	2,780	100.0
In labor force	1,645	59.2
Civilian labor force	1,645	59.2
Employed	1,410	50.7
Unemployed	235	8.5
Percent of labor force	14.3	N/A
Armed forces	4	0.1
Not in labor force	1,135	40.8
Females 16 years and older	1,450	100.0
In labor force	825	56.9
Civilian labor force	825	56.9
Employed	730	50.3
Own children under 6 years	480	100.0
All parents in family in labor force	250	52.1
Employed Native Hawaiian civilian population 16 years and older	1,410	100.0

Source: Kamehameha Schools, Aloha Counts: Census 2000 Special Tabulations for Native Hawaiians.

Native Hawaiian Employment Status: Island of O'ahu

	Number	Percent
Native Hawaiian population 16 years and older	17,905	100.0
In labor force	12,045	67.3
Civilian labor force	11,805	65.9
Employed	10,930	61.0
Unemployed	865	4.8
Percent of labor force	7.3	N/A
Armed forces	244	1.4
Not in labor force	5,865	32.8
Females 16 years and older	9,030	100.0
In labor force	5,805	64.3
Civilian labor force	5,770	63.9
Employed	5,355	59.3
Own children under 6 years	3,285	100.0
All parents in family in labor force	2,380	72.5
Employed Native Hawaiian civilian population 16 years and older	10,930	100.0

Source: Kamehameha Schools, Aloha Counts: Census 2000 Special Tabulations for Native Hawaiians.

Native Hawaiian Employment, Occupation, Industry, and Class: Statewide, 2000

	Number	Percent
Employed Native Hawaiian civilian population 16 years and older	93,595	100.0
OCCUPATION		
Managerial, professional, and related occupations	21,350	22.8
Service occupations	22,190	23.7
Sales and office occupations	27,170	29.0
Farming, fishing, and forestry occupations	1,310	1.4
Construction, extraction, and maintenance occupations	10,230	10.9
Production, transportation, and material moving occupations	11,345	12.1
INDUSTRY		
Agriculture, forestry, fishing and hunting, and mining	2,015	2.2
Construction	6,965	7.4
Manufacturing	2,770	3.0
Wholesale trade	2,955	3.2
Retail trade	11,410	12.2
Transportation and warehousing, and utilities	8,665	9.3
Information	2,315	2.5
Finance, insurance, real estate, and rental and leasing	6,140	6.6
Professional, scientific, management, administrative, and waste management services	7,785	8.3
Educational, health, and social services	15,850	16.9
Arts, entertainment, recreation, accommodation and food services	14,700	15.7
Other services (except public administration)	4,175	4.5
Public administration	7,850	8.4
CLASS OF WORKER		
Private wage and salary workers	68,360	73.0
Government workers	20,350	21.7
Self-employed workers in own not incorporated business	4,510	4.8
Unpaid family workers	370	0.4

Source: Kamehameha Schools, Aloha Counts: Census 2000 Special Tabulations for Native Hawaiians.

Native Hawaiian Employment, Occupation, Industry, and Class: Island of Hawai'i, 2000

	Number	Percent
Employed Native Hawaiian civilian population 16 years and older	15,915	100.0
OCCUPATION		
Managerial, professional, and related occupations	3,235	20.3
Service occupations	4,495	28.2
Sales and office occupations	4,095	25.7
Farming, fishing, and forestry occupations	559	3.5
Construction, extraction, and maintenance occupations	1,799	11.3
Production, transportation, and material moving occupations	1,724	10.8
INDUSTRY		
Agriculture, forestry, fishing and hunting, and mining	780	4.9
Construction	1,350	8.5
Manufacturing	373	2.3
Wholesale trade	439	2.8
Retail trade	2,050	12.9
Transportation and warehousing, and utilities	1,125	7.1
Information	233	1.5
Finance, insurance, real estate, and rental and leasing	785	4.9
Professional, scientific, management, administrative, and waste management services	1,274	8.0
Educational, health, and social services	2,605	16.4
Arts, entertainment, recreation, accommodation and food services	3,215	20.2
Other services (except public administration)	719	4.5
Public administration	984	6.2
CLASS OF WORKER		
Private wage and salary workers	11,530	72.4
Government workers	3,165	19.9
Self-employed workers in own not incorporated business	1,139	7.2
Unpaid family workers	79	0.5

Source: Kamehameha Schools, Aloha Counts: Census 2000 Special Tabulations for Native Hawaiians.

Native Hawaiian Employment, Occupation, Industry, and Class: Island of Kaua'i, 2000

	Number	Percent
Employed Native Hawaiian civilian population 16 years and older	5,165	100.0
OCCUPATION		
Managerial, professional, and related occupations	1,065	20.6
Service occupations	1,370	26.5
Sales and office occupations	1,370	26.5
Farming, fishing, and forestry occupations	150	2.9
Construction, extraction, and maintenance occupations	620	12.0
Production, transportation, and material moving occupations	595	11.5
INDUSTRY		
Agriculture, forestry, fishing and hunting, and mining	280	5.4
Construction	400	7.7
Manufacturing	70	1.4
Wholesale trade	80	1.5
Retail trade	640	12.4
Transportation and warehousing, and utilities	465	9.0
Information	90	1.7
Finance, insurance, real estate, and rental and leasing	245	4.7
Professional, scientific, management, administrative, and waste management services	400	7.7
Educational, health, and social services	710	13.7
Arts, entertainment, recreation, accommodation and food services	1,160	22.5
Other services (except public administration)	205	4.0
Public administration	415	8.0
CLASS OF WORKER		
Private wage and salary workers	3,745	72.5
Government workers	1,060	20.5
Self-employed workers in own not incorporated business	345	6.7
Unpaid family workers	18	0.3

Source: Kamehameha Schools, Aloha Counts: Census 2000 Special Tabulations for Native Hawaiians.

Native Hawaiian Employment, Occupation, Industry, and Class: Island of Lānaʻi, 2000

	Number	Percent
Employed Native Hawaiian civilian population 16 years and older	305	100.0
OCCUPATION		
Managerial, professional, and related occupations	75	24.6
Service occupations	115	37.7
Sales and office occupations	75	24.6
Farming, fishing, and forestry occupations	4	1.3
Construction, extraction, and maintenance occupations	15	4.9
Production, transportation, and material moving occupations	20	6.6
INDUSTRY		
Agriculture, forestry, fishing and hunting, and mining	10	3.3
Construction	45	14.8
Manufacturing	4	1.3
Wholesale trade	-	0.0
Retail trade	15	4.9
Transportation and warehousing, and utilities	20	6.6
Information	-	0.0
Finance, insurance, real estate, and rental and leasing	10	3.3
Professional, scientific, management, administrative, and waste management services	30	9.8
Educational, health, and social services	45	14.8
Arts, entertainment, recreation, accommodation and food services	105	34.4
Other services (except public administration)	-	0.0
Public administration	20	6.6
CLASS OF WORKER		
Private wage and salary workers	255	83.6
Government workers	45	14.8
Self-employed workers in own not incorporated business	4	1.3
Unpaid family workers	-	0.0

Source: Kamehameha Schools, Aloha Counts: Census 2000 Special Tabulations for Native Hawaiians.

Native Hawaiian Employment, Occupation, Industry, and Class: Island of Maui, 2000

	Number	Percent
Employed Native Hawaiian civilian population 16 years and older	10,400	100.0
OCCUPATION		
Managerial, professional, and related occupations	1,890	18.2
Service occupations	2,670	25.7
Sales and office occupations	3,085	29.7
Farming, fishing, and forestry occupations	155	1.5
Construction, extraction, and maintenance occupations	1,310	12.6
Production, transportation, and material moving occupations	1,285	12.4
INDUSTRY		
Agriculture, forestry, fishing and hunting, and mining	244	2.3
Construction	800	7.7
Manufacturing	294	2.8
Wholesale trade	359	3.5
Retail trade	1,280	12.3
Transportation and warehousing, and utilities	915	8.8
Information	174	1.7
Finance, insurance, real estate, and rental and leasing	675	6.5
Professional, scientific, management, administrative, and waste management services	840	8.1
Educational, health, and social services	1,490	14.3
Arts, entertainment, recreation, accommodation and food services	2,225	21.4
Other services (except public administration)	440	4.2
Public administration	660	6.3
CLASS OF WORKER		
Private wage and salary workers	8,065	77.5
Government workers	1,865	17.9
Self-employed workers in own not incorporated business	430	4.1
Unpaid family workers	58	0.6

Source: Kamehameha Schools, Aloha Counts: Census 2000 Special Tabulations for Native Hawaiians.

Native Hawaiian Employment, Occupation, Industry, and Class: Moloka'i, 2000

	Number	Percent
Employed Native Hawaiian civilian population 16 years and older	1,410	100.0
OCCUPATION		
Managerial, professional, and related occupations	320	22.7
Service occupations	470	33.3
Sales and office occupations	255	18.1
Farming, fishing, and forestry occupations	85	6.0
Construction, extraction, and maintenance occupations	120	8.5
Production, transportation, and material moving occupations	160	11.3
INDUSTRY		
Agriculture, forestry, fishing and hunting, and mining	125	8.9
Construction	75	5.3
Manufacturing	15	1.1
Wholesale trade	15	1.1
Retail trade	105	7.4
Transportation and warehousing, and utilities	130	9.2
Information	20	1.4
Finance, insurance, real estate, and rental and leasing	55	3.9
Professional, scientific, management, administrative, and waste management services	130	9.2
Educational, health, and social services	285	20.2
Arts, entertainment, recreation, accommodation and food services	250	17.7
Other services (except public administration)	75	5.3
Public administration	140	9.9
CLASS OF WORKER		
Private wage and salary workers	925	65.6
Government workers	410	29.1
Self-employed workers in own not incorporated business	70	5.0
Unpaid family workers	4	0.3

Source: Kamehameha Schools, Aloha Counts: Census 2000 Special Tabulations for Native Hawaiians.

Native Hawaiian Employment, Occupation, Industry, and Class: Island of O'ahu, 2000

	Number	Percent
Employed Native Hawaiian civilian population 16 years and older	60,295	100.0
OCCUPATION		
Managerial, professional, and related occupations	14,750	24.5
Service occupations	13,030	21.6
Sales and office occupations	18,255	30.3
Farming, fishing, and forestry occupations	328	0.5
Construction, extraction, and maintenance occupations	6,365	10.6
Production, transportation, and material moving occupations	7,550	12.5
INDUSTRY		
Agriculture, forestry, fishing and hunting, and mining	552	0.9
Construction	4,290	7.1
Manufacturing	2,015	3.3
Wholesale trade	2,050	3.4
Retail trade	7,295	12.1
Transportation and warehousing, and utilities	6,005	10.0
Information	1,799	3.0
Finance, insurance, real estate, and rental and leasing	4,385	7.3
Professional, scientific, management, administrative, and waste management services	5,130	8.5
Educational, health, and social services	10,690	17.7
Arts, entertainment, recreation, accommodation and food services	7,710	12.8
Other services (except public administration)	2,740	4.5
Public administration	5,635	9.3
CLASS OF WORKER		
Private wage and salary workers	43,805	72.7
Government workers	13,745	22.8
Self-employed workers in own not incorporated business	2,520	4.2
Unpaid family workers	222	0.4

Source: Kamehameha Schools, Aloha Counts: Census 2000 Special Tabulations for Native Hawaiians.

Distribution of Native Hawaiian Household Incomes by Island

Region	\$24,000 <	\$25,000 - \$49,999	\$50,000 - \$74,999	\$75,000 >
O'ahu	24.7%	26.4%	20.8%	28.2%
Maui	21.0%	31.5%	25.0%	22.5%
Moloka'i	43.0%	32.0%	14.9%	10.0%
Lāna'i	38.9%	31.5%	14.8%	14.8%
Hawai'i	33.2%	31.4%	18.7%	16.7%
Kaua'i	28.3%	30.7%	21.3%	19.8%
Average	31.5%	30.6%	19.3%	18.7%

Source: Kamehameha Schools, Aloha Counts: Census 2000 Special Tabulations for Native Hawaiians.

Native Hawaiian Income in 1999: Statewide

	Number	Percent
Native Hawaiian-headed households	58,790	100.0
Less than \$10,000	5,815	9.9
\$10,000 to \$14,999	3,135	5.3
\$15,000 to \$24,999	6,620	11.3
\$25,000 to \$34,999	6,850	11.7
\$35,000 to \$49,999	9,730	16.6
\$50,000 to \$74,999	12,175	20.7
\$75,000 to \$99,999	7,460	12.7
\$100,000 to \$149,999	5,100	8.7
\$150,000 to \$199,999	1,060	1.8
\$200,000 or more	845	1.4
Median household income (in dollars)	not computed	not applicable
With earnings	50,610	86.1
Mean earnings (dollars)	53,283	not applicable
With Social Security income	13,045	22.2
Mean Social Security income (dollars)	10,557	not applicable
With Supplemental Security income	2,480	4.2
Mean Supplemental Security income (dollars)	6,446	not applicable
With public assistance income	8,625	14.7
Mean public assistance income (dollars)	5,351	not applicable
With retirement income	10,665	18.1
Mean retirement income (dollars)	18,990	not applicable
Native Hawaiian-headed families	46,700	100.0
Less than \$10,000	4,065	8.7
\$10,000 to \$14,999	2,075	4.4
\$15,000 to \$24,999	4,710	10.1
\$25,000 to \$34,999	5,055	10.8
\$35,000 to \$49,000	7,790	16.7
\$50,000 to \$74,999	10,505	22.5
\$75,000 to \$99,999	6,390	13.7
\$100,000 to \$149,999	4,525	9.7
\$150,000 to \$199,999	895	1.9
\$200,000 or more	690	1.5
Median family income (dollars)	not computed	not applicable
Per capita income (dollars)	not computed	not applicable
Median earnings (dollars)	not computed	not applicable
Male full-time, year-round workers	not computed	not applicable
Female full-time, year-round workers	not computed	not applicable

Source: Kamehameha Schools, Aloha Counts: Census 2000 Special Tabulations for Native Hawaiians.

Native Hawaiian Income in 1999: Island of Hawai'i

	Number	Percent
Native Hawaiian-headed households	10,715	100.0
Less than \$10,000	1,370	12.8
\$10,000 to \$14,999	689	6.4
\$15,000 to \$24,999	1,490	13.9
\$25,000 to \$34,999	1,400	13.1
\$35,000 to \$49,999	1,960	18.3
\$50,000 to \$74,999	2,005	18.7
\$75,000 to \$99,999	999	9.3
\$100,000 to \$149,999	539	5.0
\$150,000 to \$199,999	117	1.1
\$200,000 or more	131	1.2
Median household income (in dollars)	not computed	not applicable
With earnings	9,120	85.1
Mean earnings (dollars)	not computed	not applicable
With Social Security income	2,305	21.5
Mean Social Security income (dollars)	not computed	not applicable
With Supplemental Security income	439	4.1
Mean Supplemental Security income (dollars)	not computed	not applicable
With public assistance income	1,894	17.7
Mean public assistance income (dollars)	not computed	not applicable
With retirement income	1,755	16.4
Mean retirement income (dollars)	not computed	not applicable
Native Hawaiian-headed families	8,610	100.0
Less than \$10,000	990	11.5
\$10,000 to \$14,999	509	5.9
\$15,000 to \$24,999	1,114	12.9
\$25,000 to \$34,999	1,050	12.2
\$35,000 to \$49,000	1,715	19.9
\$50,000 to \$74,999	1,695	19.7
\$75,000 to \$99,999	884	10.3
\$100,000 to \$149,999	469	5.4
\$150,000 to \$199,999	90	1.0
\$200,000 or more	95	1.1
Median family income (dollars)	not computed	not applicable
Per capita income (dollars)	not computed	not applicable
Median earnings (dollars)	not computed	not applicable
Male full-time, year-round workers	not computed	not applicable
Female full-time, year-round workers	not computed	not applicable

Source: Kamehameha Schools, Aloha Counts: Census 2000 Special Tabulations for Native Hawaiians.

Native Hawaiian Income in 1999: Island of Kaua'i

	Number	Percent
Native Hawaiian-headed households	3,135	100.0
Less than \$10,000	275	8.8
\$10,000 to \$14,999	235	7.5
\$15,000 to \$24,999	375	12.0
\$25,000 to \$34,999	400	12.8
\$35,000 to \$49,999	560	17.9
\$50,000 to \$74,999	665	21.2
\$75,000 to \$99,999	385	12.3
\$100,000 to \$149,999	165	5.3
\$150,000 to \$199,999	45	1.4
\$200,000 or more	24	0.8
Median household income (in dollars)	not computed	not applicable
With earnings	2,680	85.5
Mean earnings (dollars)	not computed	not applicable
With Social Security income	640	20.4
Mean Social Security income (dollars)	not computed	not applicable
With Supplemental Security income	130	4.1
Mean Supplemental Security income (dollars)	not computed	not applicable
With public assistance income	510	16.3
Mean public assistance income (dollars)	not computed	not applicable
With retirement income	450	14.4
Mean retirement income (dollars)	not computed	not applicable
Native Hawaiian-headed families	2,575	100.0
Less than \$10,000	245	9.5
\$10,000 to \$14,999	150	5.8
\$15,000 to \$24,999	305	11.8
\$25,000 to \$34,999	315	12.2
\$35,000 to \$49,000	480	18.6
\$50,000 to \$74,999	540	21.0
\$75,000 to \$99,999	325	12.6
\$100,000 to \$149,999	155	6.0
\$150,000 to \$199,999	35	1.4
\$200,000 or more	20	0.8
Median family income (dollars)	not computed	not applicable
Per capita income (dollars)	not computed	not applicable
Median earnings (dollars)	not computed	not applicable
Male full-time, year-round workers	not computed	not applicable
Female full-time, year-round workers	not computed	not applicable

Source: Kamehameha Schools, Aloha Counts: Census 2000 Special Tabulations for Native Hawaiians.

Native Hawaiian Income in 1999: Island of Lānaʻi

	Number	Percent
Native Hawaiian-headed households	200	100.0
Less than \$10,000	30	15.0
\$10,000 to \$14,999	4	2.0
\$15,000 to \$24,999	45	22.5
\$25,000 to \$34,999	4	2.0
\$35,000 to \$49,999	60	30.0
\$50,000 to \$74,999	30	15.0
\$75,000 to \$99,999	20	10.0
\$100,000 to \$149,999	10	5.0
\$150,000 to \$199,999	-	0.0
\$200,000 or more	-	0.0
Median household income (in dollars)	not computed	not applicable
With earnings	170	85.0
Mean earnings (dollars)	38,057	not applicable
With Social Security income	40	20.0
Mean Social Security income (dollars)	6,128	not applicable
With Supplemental Security income	10	5.0
Mean Supplemental Security income (dollars)	3,234	not applicable
With public assistance income	25	12.5
Mean public assistance income (dollars)	4,269	not applicable
With retirement income	30	15.0
Mean retirement income (dollars)	13,013	not applicable
Native Hawaiian-headed families	145	100.0
Less than \$10,000	25	17.2
\$10,000 to \$14,999	-	0.0
\$15,000 to \$24,999	20	13.8
\$25,000 to \$34,999	15	10.3
\$35,000 to \$49,000	35	24.1
\$50,000 to \$74,999	30	20.7
\$75,000 to \$99,999	15	10.3
\$100,000 to \$149,999	10	6.9
\$150,000 to \$199,999	-	0.0
\$200,000 or more	-	0.0
Median family income (dollars)	not computed	not applicable
Per capita income (dollars)	not computed	not applicable
Median earnings (dollars)	not computed	not applicable
Male full-time, year-round workers	not computed	not applicable
Female full-time, year-round workers	not computed	not applicable

Source: Kamehameha Schools, Aloha Counts: Census 2000 Special Tabulations for Native Hawaiians.

Native Hawaiian Income in 1999: Island of Maui

	Number	Percent
Native Hawaiian-headed households	6,015	100.0
Less than \$10,000	450	7.5
\$10,000 to \$14,999	300	5.0
\$15,000 to \$24,999	515	8.6
\$25,000 to \$34,999	725	12.1
\$35,000 to \$49,999	1,170	19.5
\$50,000 to \$74,999	1,505	25.0
\$75,000 to \$99,999	800	13.3
\$100,000 to \$149,999	360	6.0
\$150,000 to \$199,999	88	1.5
\$200,000 or more	108	1.8
Median household income (in dollars)	not computed	not applicable
With earnings	5,375	89.4
Mean earnings (dollars)	not computed	not applicable
With Social Security income	1,225	20.4
Mean Social Security income (dollars)	not computed	not applicable
With Supplemental Security income	200	3.3
Mean Supplemental Security income (dollars)	not computed	not applicable
With public assistance income	725	12.1
Mean public assistance income (dollars)	not computed	not applicable
With retirement income	960	16.0
Mean retirement income (dollars)	not computed	not applicable
Native Hawaiian-headed families	4,770	100.0
Less than \$10,000	355	7.4
\$10,000 to \$14,999	150	3.1
\$15,000 to \$24,999	340	7.1
\$25,000 to \$34,999	545	11.4
\$35,000 to \$49,000	960	20.1
\$50,000 to \$74,999	1,230	25.8
\$75,000 to \$99,999	755	15.8
\$100,000 to \$149,999	295	6.2
\$150,000 to \$199,999	58	1.2
\$200,000 or more	103	2.2
Median family income (dollars)	not computed	not applicable
Per capita income (dollars)	not computed	not applicable
Median earnings (dollars)	not computed	not applicable
Male full-time, year-round workers	not computed	not applicable
Female full-time, year-round workers	not computed	not applicable

Source: Kamehameha Schools, Aloha Counts: Census 2000 Special Tabulations for Native Hawaiians.

Native Hawaiian Income in 1999: Island of Molokaʻi

	Number	Percent
Native Hawaiian-headed households	1,140	100.0
Less than \$10,000	195	17.1
\$10,000 to \$14,999	90	7.9
\$15,000 to \$24,999	205	18.0
\$25,000 to \$34,999	145	12.7
\$35,000 to \$49,999	220	19.3
\$50,000 to \$74,999	170	14.9
\$75,000 to \$99,999	50	4.4
\$100,000 to \$149,999	45	3.9
\$150,000 to \$199,999	4	0.4
\$200,000 or more	15	1.3
Median household income (in dollars)	not computed	not applicable
With earnings	935	82.0
Mean earnings (dollars)	42,115	not applicable
With Social Security income	300	26.3
Mean Social Security income (dollars)	9,940	not applicable
With Supplemental Security income	55	4.8
Mean Supplemental Security income (dollars)	6,252	not applicable
With public assistance income	250	21.9
Mean public assistance income (dollars)	6,296	not applicable
With retirement income	185	16.2
Mean retirement income (dollars)	12,770	not applicable
Native Hawaiian-headed families	930	100.0
Less than \$10,000	120	12.9
\$10,000 to \$14,999	60	6.5
\$15,000 to \$24,999	185	19.9
\$25,000 to \$34,999	115	12.4
\$35,000 to \$49,000	185	19.9
\$50,000 to \$74,999	150	16.1
\$75,000 to \$99,999	55	5.9
\$100,000 to \$149,999	45	4.8
\$150,000 to \$199,999	4	0.4
\$200,000 or more	15	1.6
Median family income (dollars)		
Per capita income (dollars)	not computed	not applicable
Median earnings (dollars)	not computed	not applicable
Male full-time, year-round workers	not computed	not applicable
Female full-time, year-round workers	not computed	not applicable

Source: Kamehameha Schools, Aloha Counts: Census 2000 Special Tabulations for Native Hawaiians.

Native Hawaiian Income in 1999: Island of O'ahu

	Number	Percent
Native Hawaiian-headed households	37,450	100.0
Less than \$10,000	3,444	9.2
\$10,000 to \$14,999	1,809	4.8
\$15,000 to \$24,999	3,985	10.6
\$25,000 to \$34,999	4,110	11.0
\$35,000 to \$49,999	5,770	15.4
\$50,000 to \$74,999	7,790	20.8
\$75,000 to \$99,999	5,200	13.9
\$100,000 to \$149,999	3,980	10.6
\$150,000 to \$199,999	814	2.2
\$200,000 or more	567	1.5
Median household income (in dollars)	not computed	not applicable
With earnings	32,235	86.1
Mean earnings (dollars)	not computed	not applicable
With Social Security income	8,530	22.8
Mean Social Security income (dollars)	not computed	not applicable
With Supplemental Security income	1,640	4.4
Mean Supplemental Security income (dollars)	not computed	not applicable
With public assistance income	5,215	13.9
Mean public assistance income (dollars)	not computed	not applicable
With retirement income	7,260	19.4
Mean retirement income (dollars)	not computed	not applicable
Native Hawaiian-headed families	29,625	100.0
Less than \$10,000	2,325	7.8
\$10,000 to \$14,999	1,212	4.1
\$15,000 to \$24,999	2,744	9.3
\$25,000 to \$34,999	2,970	10.0
\$35,000 to \$49,000	4,400	14.9
\$50,000 to \$74,999	6,855	23.1
\$75,000 to \$99,999	4,360	14.7
\$100,000 to \$149,999	3,560	12.0
\$150,000 to \$199,999	724	2.4
\$200,000 or more	462	1.6
Median family income (dollars)	not computed	not applicable
Per capita income (dollars)	not computed	not applicable
Median earnings (dollars)	not computed	not applicable
Male full-time, year-round workers	not computed	not applicable
Female full-time, year-round workers	not computed	not applicable

Source: Kamehameha Schools, Aloha Counts: Census 2000 Special Tabulations for Native Hawaiians.

Household Income: Hawai'i Health Survey, 2003

Household Income	County									
	Honolulu		Hawai'i		Kaua'i		Maui		Total	
	Number	Percent	Number	Percent	Number	Percent	Number	Percent	Number	Percent
STATEWIDE										
< \$5,000	5,477	0.6%	2,879	1.9%	578	1.0%	1,812	1.4%	10,745	0.9%
\$5,000 - \$9,999	20,445	2.3%	4,976	3.2%	1,320	2.2%	4,839	3.6%	31,580	2.6%
\$10,000 - \$14,999	28,716	3.3%	9,341	6.0%	2,118	3.5%	5,078	3.8%	45,253	3.7%
\$15,000 - \$19,999	28,587	3.3%	10,935	7.1%	2,744	4.6%	4,952	3.7%	47,218	3.9%
\$20,000 - \$24,999	43,789	5.0%	9,922	6.4%	3,489	5.8%	7,223	5.4%	64,422	5.3%
\$25,000 - \$29,999	39,058	4.5%	11,183	7.2%	2,887	4.8%	7,062	5.3%	60,190	4.9%
\$30,000 - \$34,999	44,312	5.1%	14,939	9.7%	4,604	7.7%	9,011	6.7%	72,865	6.0%
\$35,000 - \$39,999	32,859	3.8%	7,968	5.2%	3,176	5.3%	3,995	3.0%	47,997	3.9%
\$40,000 - \$44,999	43,630	5.0%	6,686	4.3%	5,382	9.0%	8,370	6.2%	64,068	5.2%
\$45,000 - \$49,999	42,174	4.8%	6,198	4.0%	3,211	5.4%	6,805	5.1%	58,388	4.8%
\$50,000 - \$54,999	64,700	7.4%	14,744	9.5%	5,050	8.4%	13,997	10.4%	98,491	8.1%
\$55,000 - \$59,999	23,324	2.7%	4,732	3.1%	1,917	3.2%	5,336	4.0%	35,309	2.9%
\$60,000 - \$74,999	118,781	13.6%	18,237	11.8%	6,957	11.6%	18,664	13.9%	162,638	13.3%
\$75,000 - \$99,999	151,776	17.4%	16,513	10.7%	9,793	16.3%	19,010	14.2%	197,093	16.1%
\$100,00 - \$149,999	130,980	15.0%	11,121	7.2%	5,119	8.5%	11,875	8.9%	159,095	13.0%
> \$150,000	55,100	6.3%	4,154	2.7%	1,605	2.7%	6,069	4.5%	66,929	5.5%

Household Income: Hawai'i Health Survey, 2003

Household Income	County									
	Honolulu		Hawai'i		Kaua'i		Maui		Total	
	Number	Percent	Number	Percent	Number	Percent	Number	Percent	Number	Percent
NATIVE HAWAIIAN										
< \$5,000	*	*	1,251	2.8%	*	*	704	2.3%	3,081	1.2%
\$5,000 - \$9,999	6,680	3.9%	1,153	2.6%	*	*	1,579	5.2%	9,659	3.7%
\$10,000 - \$14,999	7,300	4.3%	3,142	7.0%	318	2.3%	1,265	4.2%	12,025	4.7%
\$15,000 - \$19,999	5,587	3.3%	3,538	7.9%	828	6.1%	864	2.8%	10,818	4.2%
\$20,000 - \$24,999	10,170	6.0%	2,822	6.3%	501	3.7%	2,101	6.9%	15,594	6.0%
\$25,000 - \$29,999	5,075	3.0%	3,752	8.4%	836	6.2%	2,551	8.4%	12,213	4.7%
\$30,000 - \$34,999	5,871	3.5%	5,075	11.4%	1,013	7.5%	2,342	7.7%	14,300	5.5%
\$35,000 - \$39,999	7,771	4.6%	2,596	5.8%	1,045	7.7%	874	2.9%	12,287	4.8%
\$40,000 - \$44,999	12,660	7.4%	1,771	4.0%	1,261	9.3%	1,607	5.3%	17,298	6.7%
\$45,000 - \$49,999	8,343	4.9%	1,602	3.6%	729	5.4%	1,366	4.5%	12,040	4.7%
\$50,000 - \$54,999	13,455	7.9%	4,373	9.8%	1,523	11.3%	3,014	9.9%	22,365	8.7%
\$55,000 - \$59,999	*	*	1,654	3.7%	508	3.8%	1,500	4.9%	6,777	2.6%
\$60,000 - \$74,999	17,224	10.1%	4,793	10.7%	1,531	11.3%	3,891	12.8%	27,439	10.6%
\$75,000 - \$99,999	30,898	18.2%	4,632	10.4%	2,056	15.2%	4,660	15.4%	42,246	16.3%
\$100,00 - \$149,999	21,904	12.9%	2,043	4.6%	814	6.0%	1,331	4.4%	26,093	10.1%
> \$150,000	12,834	7.6%	455	1.0%	274	2.0%	692	2.3%	14,255	5.5%

Source: Office of Health Status Monitoring, Hawaii State Department of Health

Note:

* Sample numbers provisionally

nes are not represented, see HHS Procedure Manual 2003

* Row and / or column totals may not sum to totals listed due to rounding

* If sample numerator <50 or sample denominator <50, data are not reliable

* Sample size 14,839 people

Native Hawaiian-Owned Firms by Geographic Location

State / Region	Total	East North Central	
		Wisconsin	123
		Illinois	458
		Indiana	183
		Ohio	294
		Michigan	84
		East South Central	
		Kentucky	56
		Tennessee	85
		Mississippi	94
		Alabama	12
		South Atlantic	
		Georgia	89
		Florida	1,281
		South Carolina	35
		North Carolina	76
		Virginia	266
		West Virginia	5
		District of Columbia	1
		Maryland	132
		Delaware	3
		Middle Atlantic	
		New York	381
		Pennsylvania	194
		New Jersey	367
		North Atlantic	
		Maine	4
		Vermont	-
		New Hampshire	44
		Massachusetts	data withheld
		Rhode Island	16
		Connecticut	80
		TOTAL	15,544
Pacific			
Alaska	61		
California	2,167		
Hawai'i	6,600		
Oregon	247		
Washington	286		
Mountain			
Nevada	118		
Arizona	146		
New Mexico	117		
Colorado	226		
Utah	147		
Wyoming	10		
Idaho	15		
Montana	45		
W. North Central			
North Dakota	3		
South Dakota	-		
Nebraska	7		
Kansas	42		
Minnesota	61		
Iowa	28		
Missouri	90		
W. South Central			
Texas	616		
Oklahoma	93		
Arkansas	20		
Louisiana	28		

Source: 1997 Economic Census

States with Largest Number of Hawaiian-Owned Firms

State	# of Hawaiian-Owned firms (1997 Economic Census)	Native Hawaiian population (2000 Census)
Hawai'i**	6,600	239,655
California**	2,167	60,048
Florida**	1,281	5,285
Texas**	616	7,775
Illinois	458	2,506
New York**	381	3,758
New Jersey	367	1,501
Ohio	294	1,989
Washington**	286	13,507
Virginia	266	2,795

Source: 1997 Economic Census and 2000 U.S. Census

** denotes that a state is one of the top ten with largest population of Native Hawaiians.

Native Hawaiians in Business in the USA

Total # of Native Hawaiian-owned Firms in the USA	15,544
Total firms in USA (any)	20,821,935
Total Number of Employees in Native Hawaiian-owned Firms	20,698
Total Number of Employees in ALL Firms	103,359,815
Total Sales and Receipts from Native Hawaiian-owned Firms	\$2,250,153,000
Total Sales and Receipts from ALL Firms	\$18,553,243,047,000

Source: U.S. Census Bureau, 1997 Economic Census, Women and Minority-Owned Firms

Distribution of Native Hawaiian-Owned Firms by Industry

Industry	Percent
Service Industry	44
Industries Not Classified	18
Retail Industry	11
Construction	7
Agricultural Services	5
Wholesale Trade	4
Transportation, Communications, etc.	4
Finance, Insurance, and Real Estate	4
Manufacturing	3

Native Hawaiian-Owned Firms in Service Industry by Sub-Type

Sub-type	Percent
Business Services	33
Engineering, Management, Accounting	19
Amusement and Recreation	12
Personal Services	9
Health Services	7
Social Services	5
Automotive Repair	3
Legal Services	3
Educational Services	3
Miscellaneous Repair	2
Services, n.e.c.	2
Motion Pictures	1
Hotels and Other Lodging	1

Source: 1997 Economic Census

ECONOMIC DEVELOPMENT RESOURCES

Hawai'i State Department of Commerce and Consumer Affairs (DCCA)

Business Registration
335 Merchant Street
Honolulu, HI 96813
Phone: (808) 586-2744
Fax: (808) 586-2733

Professional and Vocational Licensing

Phone: (808) 586-3000

Insurance Division

Phone: (808) 586-2790
Fax: (808) 586-2806

Consumer Protection

235 South Beretania Street, Suite 801
Honolulu, HI 96813
Phone: (808) 586-2630
Fax: (808) 586-2640
Website: <http://www.hawaii.gov/dcca>

Hawai'i Small Business Development Center

308 Kamehameha Avenue, Suite 201
Hilo, HI 96720
Phone: (808) 974-7515
Fax: (808) 974-7683
Website: <http://www.hawaii-sbdc.org>

Native Hawaiian Research Center

Pacific American Foundation

33 South King Street, Suite 205
Honolulu, HI 96813
Phone: (808) 533-2836
Website: <http://www.thepaf.org/Research/NHRC.htm>

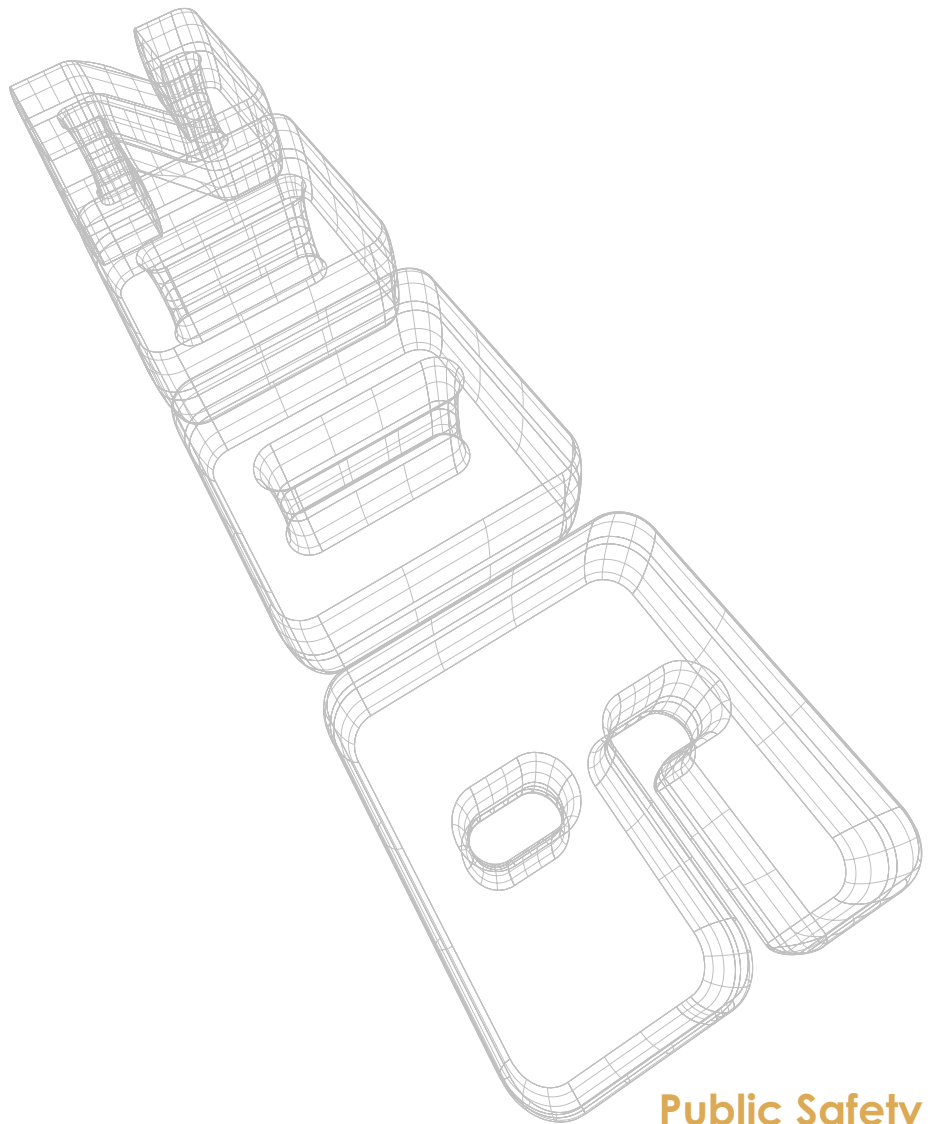

Public Safety

PUBLIC SAFETY

In today's society, racial groups at the lower end of the economic ladder are more likely to resort to violence and crime in their quest for economic and social equality. As a result, they comprise a large segment of the inmate population in state and federal prisons.

Among the racial groups in Hawaii, Native Hawaiians constitute a disproportionate number of minorities in Hawaii's public safety system, representing approximately 40% of all inmates incarcerated in Hawaii and contracted facilities on the continent. While the number of Native Hawaiians in Hawaii's public safety system remains consistent, Native Hawaiians continue to suffer the state's highest incarceration rates.

Data also indicate Native Hawaiian youth are a disproportionate minority in the juvenile justice system, representing approximately 36% of all juveniles arrested for index and part II offenses statewide. Burglary, larceny, assault, marijuana drug use, and status offenses (i.e. runaways) account for the majority of crimes committed by Native Hawaiian youth.

Despite increases in drug use and drug related crimes across all ethnic groups in Hawai'i, more background information is needed to assess the current status of Native Hawaiians with particular focus on determining potential causes for unlawful behavior and ascertaining preventive and/or corrective measures to curb imprisonment.

**Distribution of Inmate Population by Ethnic Group or Race in
Hawai'i Correctional Facilities: As of June 30, 2004**

Race	Males Percentage	Females Percentage	TOTAL Percentage
Total Number	3,716	620	4,336
African American	4%	3%	4%
Caucasian	22%	27%	23%
Chinese	1%	1%	1%
Filipino	14%	10%	13%
Hawaiian / Part Hawaiian	37%	44%	38%
Hispanic	3%	2%	3%
Japanese	5%	4%	5%
Korean	1%	1%	1%
Samoaan	5%	3%	5%
Other Pacific Islander	3%	1%	2%
Other*	2%	2%	3%
Not reported	2%	2%	2%
TOTAL	100%	100%	100%

Source: State of Hawai'i Department of Public Safety

**Total inmate counts based on facility tabulations. It represents the number of inmates physically housed in the facility and inmates on the "out count" such as on furlough, in hospitals, intermittent leave, transition housing, etc. It excludes inmates housed in contracted out-of-state facilities and other out-of-state facilities.*

Percentage distributions based on inmate records from Offendertrak, Hawai'i Department of Public Safety.

Sum of percentages may not equal total due to rounding.

***Ethnicity and race based on information provided by inmates.*

**Other includes Native American Indian, Vietnamese, other Asians, etc.*

**Distribution of Inmate Population by Ethnic Group or Race in
Hawai'i Correctional Facilities: As of June 30, 2005**

Race	Males Percentage	Females Percentage	TOTAL Percentage
Total Number	3,641	671	4,312
African American	4%	3%	4%
Caucasian	22%	27%	23%
Chinese	1%	1%	1%
Filipino	14%	10%	13%
Hawaiian / Part Hawaiian	37%	44%	38%
Hispanic	3%	2%	3%
Japanese	5%	4%	5%
Korean	1%	1%	1%
Samoaan	5%	3%	5%
Other Pacific Islander	2%	1%	2%
Other*	3%	2%	3%
Not reported	2%	2%	2%
TOTAL	100%	100%	100%

Source: State of Hawai'i Department of Public Safety

**Total inmate counts based on facility tabulations. It represents the number of inmates physically housed in the facility and inmates on the „out count“ such as on furlough, in hospitals, intermittent leave, transition housing, etc. It excludes inmates housed in contracted out-of-state facilities and other out-of-state facilities.*

Percentage distributions based on inmate records from Offendertrak, Hawai'i Department of Public Safety.

Sum of percentages may not equal total due to rounding.

***Ethnicity and race based on information provided by inmates.*

**Other includes Native American Indian, Vietnamese, other Asians, etc.*

**Distribution of Inmate Population by Ethnic Group or Race in
Out-of-State Correctional Facilities: As of June 30, 2004**

Race	Males Percentage	Females Percentage	Total Percentage
Total Number	1,553	69	1,622
African American	5%	6%	5%
Caucasian	21%	22%	21%
Chinese	1%	1%	1%
Filipino	12%	5%	12%
Hawaiian / Part Hawaiian	41%	47%	41%
Hispanic	3%	2%	3%
Japanese	5%	3%	5%
Korean	1%	2%	1%
Samoa	7%	8%	7%
Other Pacific Islander	1%	1%	1%
Other*	2%	2%	2%
Not reported	1%	1%	2%
TOTAL	100%	100%	100%

Source: State of Hawai'i Department of Public Safety

* Total inmate counts include inmates housed in contracted out-of-state facilities and other out-of-state facilities.

Percentage distributions based on inmate records from Offendertrak, Hawai'i Department of Public Safety.

Sum of percentages may not equal total due to rounding.

** Ethnicity and race based on information provided by inmates.

Other includes Native American Indian, Vietnamese, other Asians, etc.

**Distribution of Inmate Population by Ethnic Group or Race in
Out-of-State Correctional Facilities: As of June 30, 2005**

Race	Males Percentage	Females Percentage	Total Percentage
Total Number	1,693	87	1,780
African American	5%	6%	5%
Caucasian	21%	22%	21%
Chinese	1%	1%	1%
Filipino	12%	5%	12%
Hawaiian / Part Hawaiian	41%	47%	41%
Hispanic	3%	2%	3%
Japanese	5%	3%	5%
Korean	1%	2%	1%
Samoaan	7%	8%	7%
Other Pacific Islander	1%	1%	1%
Other*	2%	1%	2%
Not reported	1%	1%	2%
TOTAL	100%	100%	100%

Source: State of Hawai'i Department of Public Safety

* Total inmate counts include inmates housed in contracted out-of-state facilities and other out-of-state facilities.

Percentage distributions based on inmate records from Offendertrak, Hawai'i Department of Public Safety.

Sum of percentages may not equal total due to rounding.

** Ethnicity and race based on information provided by inmates.

Other includes Native American Indian, Vietnamese, other Asians, etc.

State of Hawai'i Adult & Juvenile Arrests by Index Offenses: 2003

	Index Offenses	Adults		Juveniles		TOTAL
		Number	Percent	Number	Percent	
Violent Crime	Total Violent	1,092	80.6	263	19.4	1,355
	Murder	24	92.3	2	7.7	26
	Forcible Rape	111	87.4	16	12.6	127
	Robbery	322	70.5	135	29.5	457
	Aggravated Assault	635	85.2	110	14.8	745
Property Crime	Total Property	4,860	72.4	1,850	27.6	6,710
	Burglary	547	69.8	237	30.2	784
	Larceny - Theft	3,351	70.4	1,408	29.6	4,759
	Motor Vehicle Theft	952	82.7	199	17.3	1,151
	Arson	10	62.5	6	37.5	16
TOTAL INDEX		5,952	73.8	2,133	26.2	8,065

Source: State of Hawai'i Attorney General, Crime Prevention & Justice Assistance Division

State of Hawai'i Race/Ethnicity of Murder Victims and Known Offenders: 2003

Race	Victims		Offenders		Percent of State Population (CY 2000)
	Number	Percent	Number	Percent	
Caucasian	8	36.4%	5	31.3%	33.4%
Filipino	0	0.0%	1	6.3%	15.2%
Hawaiian / Part Hawaiian	5	22.7%	6	37.5%	12.5%
Japanese	4	18.2%	2	12.5%	22.3%
Samoan	1	4.5%	1	6.3%	1.4%
Korean	0	0.0%	0	0.0%	2.2%
African American	1	4.5%	1	6.3%	2.5%
Chinese	1	4.5%	0	0.0%	6.2%
American Indian	0	0.0%	0	0.0%	0.5%
Other	2	9.1%	0	0.0%	3.9%
TOTAL	22	100%	16	100%	100%

Source: State of Hawai'i Department of the Attorney General, Crime Prevention & Justice Assistance Division

State of Hawai'i Race/Ethnicity of Adults Arrested for Index Offenses: 2003

Offense / Row %	Caucasian	African American	Indian	Chinese	Japanese	Filipino	Hawaiian	Korean	Samoaan	Other	Total
Murder	5	2	-	-	3	5	5	-	1	3	24
	20.8%	8.3%	0%	0%	12.5%	20.8%	20.8%	0%	4.2%	12.5%	100%
Forcible Rape	41	13	-	1	6	11	19	-	5	15	111
	36.9%	11.7%	0%	0.9%	5.4%	9.9%	17.1%	0%	4.5%	13.5%	100%
Robbery	82	25	3	3	9	33	101	6	24	36	322
	25.5%	7.8%	0.9%	0.9%	2.8%	10.2%	31.4%	1.9%	7.5%	11.2%	100%
Aggravated Assault	176	34	3	11	27	77	165	8	42	92	635
	27.7%	5.4%	0.5%	1.7%	4.3%	12.1%	26%	1.3%	6.6%	14.5%	100%
Burglary	185	18	-	6	24	60	172	3	21	58	547
	33.8%	3.3%	0%	1.1%	4.4%	11%	31.4%	0.5%	3.8%	10.6%	100%
Larceny - Theft	1,242	125	5	55	249	380	786	42	89	378	3,351
	37.1%	3.7%	0.1%	1.6%	7.4%	11.3%	23.5%	1.3%	2.7%	11.3%	100%
Motor Vehicle Theft	256	15	1	14	45	135	354	9	36	87	952
	26.9%	1.6%	0.1%	1.5%	4.7%	14.2%	37.2%	0.9%	3.8%	9.1%	100%
Arson	7	-	-	-	-	-	2	1	-	-	10
	70%	0%	0%	0%	0%	0%	20%	10%	0%	0%	100%
TOTAL	1,994	232	12	90	363	701	1,604	69	218	669	5,952
Column Percent	34%	4%	0%	2%	6%	12%	27%	1%	4%	11%	100%

Source: State of Hawai'i Attorney General, Crime Prevention & Justice Assistance Division

State of Hawai'i Race/Ethnicity of Juveniles Arrested for Index Offenses: 2003

Offense / Row %	Caucasian	African American	Indian	Chinese	Japanese	Filipino	Hawaiian	Korean	Samoan	Other	Total
Murder	-	-	-	-	-	1	1	-	-	-	2
	0%	0%	0%	0%	0%	50%	50%	0%	0%	0%	100%
Forcible Rape	4	4	-	-	-	1	6	-	-	1	16
	25%	25%	0%	0%	0%	6.3%	37.5%	0%	0%	6.3%	100%
Robbery	14	5	-	1	1	11	59	1	24	19	135
	10.4%	3.7%	0%	0.7%	0.7%	8.1%	43.7%	0.7%	17.8%	14.1%	100%
Aggravated Assault	11	4	-	2	6	10	44	1	15	17	110
	10.0%	3.6%	0%	1.8%	5.5%	9.1%	40%	0.9%	13.6%	15.5%	100%
Burglary	60	4	-	1	4	24	102	-	12	30	237
	25.3%	1.7%	0%	0.4%	1.7%	10.1%	43%	0%	5.1%	12.7%	100%
Larceny - Theft	328	33	-	25	87	208	466	17	75	169	1,408
	23.3%	2.3%	0%	1.8%	6.2%	14.8%	33.1%	1.2%	5.3%	12%	100%
Motor Vehicle Theft	40	4	-	-	14	40	86	1	2	12	199
	20.1%	2%	0%	0%	7%	20.1%	43.2%	0.5%	1%	6%	100%
Arson	1	1	-	-	-	2	2	-	-	-	6
	16.7%	16.7%	0%	0%	0%	33.3%	33.3%	0%	0%	0%	100%
TOTAL	458	55	-	29	112	297	766	20	128	248	2,113
Column Percent	21.7%	2.6%	0%	1.4%	5.3%	14.1%	36.3%	0.9%	6.1%	11.7%	100%

Source: State of Hawai'i Attorney General, Crime Prevention & Justice Assistance Division

State of Hawai'i Race/Ethnicity of Adults Arrested for Part II Offenses: 2003

Type	Offense	Race/Ethnicity										Total
		Caucasian	African American	Indian	Chinese	Japanese	Filipino	Hawaiian	Korean	Samoaan	Other	
Violent	Negligent Manslaughter	5	-	-	-	1	-	4	-	-	3	13
		38.5%	0%	0%	0%	7.7%	0%	30.8%	0%	0%	23.1%	100%
	Other Assault	1,121	157	8	46	170	448	1,013	31	146	485	3,625
		30.9%	4.3%	0.2%	1.3%	4.7%	12.4%	27.9%	0.9%	4%	13.4%	100%
	98145.451	96	19	1	5	31	42	39	8	12	33	286
33.6%		6.6%	0.3%	1.7%	10.8%	14.7%	13.6%	2.8%	4.2%	11.5%	100%	
Property - Related	Forgery	71	19	2	11	34	79	94	5	10	40	365
		19.5%	5.2%	0.5%	3%	9.3%	21.6%	25.8%	1.4%	2.7%	11%	100%
	Fraud	131	10	1	29	26	63	87	11	2	29	389
		33.7%	2.6%	0.3%	7.5%	6.7%	16.2%	22.4%	2.8%	0.5%	7.5%	100%
	Embezzlement	12	1	1	-	5	13	5	-	-	3	40
		30%	2.5%	2.5%	0%	12.5%	32.5%	12.5%	0%	0%	7.5%	100%
	Stolen Property	40	3	-	1	18	19	50	2	4	18	155
25.8%		1.9%	0%	0.6%	11.6%	12.3%	32.3%	1.3%	2.6%	11.6%	100%	
Vandalism	150	17	1	5	30	62	126	6	29	64	490	
	30.6%	3.5%	0.2%	1%	6.1%	12.7%	25.7%	1.2%	5.9%	13.1%	100%	
Drug Manufacturing / Sale	Opium or Cocaine	33	11	1	1	6	12	26	1	5	11	107
		30.8%	10.3%	0.9%	0.9%	5.6%	11.2%	24.3%	0.9%	4.7%	10.3%	100%
	Marijuana	70	6	2	7	6	13	50	-	-	5	159
		44%	3.8%	1.3%	4.4%	3.8%	8.2%	31.4%	0%	0%	3.1%	100%
	Synthetic Narcotic	14	2	-	1	6	4	11	1	2	9	50
		28%	4%	0%	2%	12%	8%	22%	2%	4%	18%	100%
Nonnarcotic	83	10	1	7	15	49	97	4	2	29	297	
	27.9%	3.4%	0.3%	2.4%	5.1%	16.5%	32.7%	1.3%	0.7%	9.8%	100%	

State of Hawai'i Race/Ethnicity of Adults Arrested for Part II Offenses: 2003 - Continued

Type	Offense	Race/Ethnicity										Total
		Caucasian	African American	Indian	Chinese	Japanese	Filipino	Hawaiian	Korean	Samoaan	Other	
Drug Possession	Opium or Cocaine	102	25	1	4	34	30	68	5	26	44	339
		30.1%	7.4%	0.3%	1.2%	10%	8.8%	20.1%	1.5%	7.7%	13.0%	100%
	Marijuana	263	22	1	9	40	57	159	11	20	53	635
		41.4%	3.5%	0.2%	1.4%	6.3%	9%	25%	1.7%	3.1%	8.3%	100%
	Synthetic Narcotic	32	4	-	2	11	31	38	1	5	14	138
		23.2%	2.9%	0%	1.4%	8%	22.5%	27.5%	0.7%	3.6%	10.1%	100%
Nonnarcotic	278	11	-	12	82	232	291	5	14	71	996	
	27.9%	1.1%	0%	1.2%	8.2%	23.3%	29.2%	0.5%	1.4%	7.1%	100%	
Gambling	Bookmaking	-	-	-	-	-	-	-	-	-	-	-
		0%	0%	0%	0%	0%	0%	0%	0%	0%	0%	0%
	Numbers & Lottery	-	-	-	-	-	-	-	-	-	-	-
		0%	0%	0%	0%	0%	0%	0%	0%	0%	0%	0%
Other	23	-	-	4	9	72	20	1	6	29	164	
	14%	0%	0%	2.4%	5.5%	43.9%	12.2%	0.6%	3.7%	17.7%	100%	
Alcohol - Related	DUI	1,708	92	10	79	414	399	602	77	92	504	3,977
		42.9%	2.3%	0.3%	2%	10.4%	10%	15.1%	1.9%	2.3%	12.7%	100%
	Liquor Laws	348	26	2	13	49	96	178	6	48	170	936
		37.2%	2.8%	0.2%	1.4%	5.2%	10.3%	19%	0.6%	5.1%	18.2%	100%
	Disorderly Conduct	241	26	1	4	21	43	123	8	28	69	564
		42.7%	4.6%	0.2%	0.7%	3.7%	7.6%	21.8%	1.4%	5%	12.2%	100%

State of Hawai'i Race/Ethnicity of Adults Arrested for Part II Offenses: 2003 - Continued

Type	Offense	Race/Ethnicity										Total
		Caucasian	African American	Indian	Chinese	Japanese	Filipino	Hawaiian	Korean	Samoan	Other	
Other	Offenses Agst. Family/Children	181	39	-	20	56	124	207	16	57	126	826
		21.9%	4.7%	0%	2.4%	6.8%	15%	25.1%	1.9%	6.9%	15.3%	100%
	Prostitution	93	34	-	16	22	34	31	50	11	48	339
		27.4%	10%	0%	4.7%	6.5%	10%	9.1%	14.7%	3.2%	14.2%	100%
	Suspicion	-	-	-	-	-	-	-	-	-	-	-
		0%	0%	0%	0%	0%	0%	0%	0%	0%	0%	0%
	Vagrancy	-	-	-	-	-	-	-	-	-	-	-
		0%	0%	0%	0%	0%	0%	0%	0%	0%	0%	0%
	Weapons	85	8	-	5	17	47	56	4	11	31	264
		32.2%	3%	0%	1.9%	6.4%	17.8%	21.2%	1.5%	4.2%	11.7%	100%
All Other Offenses	8,502	814	49	354	1,297	3,205	7,019	192	721	3,718	25,871	
	32.9%	3.1%	0.2%	1.4%	5%	12.4%	27.1%	0.7%	2.8%	14.4%	100%	
TOTAL		13,682	1,356	82	635	2,400	5,174	10,394	445	1,251	5,606	41,025
Column Percent		33.4%	3.3%	0.2%	1.5%	5.9%	12.6%	25.3%	1.1%	3%	13.7%	100%

Source: State of Hawai'i Department of the Attorney General, Crime Prevention & Justice Assistance Division

State of Hawai'i Race/Ethnicity of Juveniles Arrested for Part II Offenses: 2003

Type	Offense	Caucasian	African American	Indian	Chinese	Japanese	Filipino	Hawaiian	Korean	Samoan	Other	Total
Violent	Negligent Manslaughter	-	-	-	-	2	-	-	-	-	-	2
		0%	0%	0%	0%	100%	0%	0%	0%	0%	0%	100%
	Other Assault	186	36	-	8	40	155	435	7	85	134	1,086
		17.1%	3.3%	0%	0.7%	3.7%	14.3%	40.1%	0.6%	7.8%	12.3%	100%
	Sex Offenses	15	3	-	-	3	17	24	1	11	22	96
15.6%		3.1%	0%	0%	3.1%	17.7%	25%	1%	11.5%	22.9%	100%	
Property - Related	Forgery	3	-	-	1	-	2	4	-	-	3	13
		23.1%	0%	0%	7.7%	0%	15.4%	30.8%	0%	0%	23.1%	100%
	Fraud	10	1	-	-	1	1	7	-	-	4	24
		41.7%	4.2%	0%	0%	4.2%	4.2%	29.2%	0%	0%	16.7%	100%
	Embezzlement	1	-	-	-	-	1	1	-	-	-	3
		33.3%	0%	0%	0%	0%	33.3%	33.3%	0%	0%	0%	100%
	Stolen Property	6	1	-	-	-	8	12	-	-	1	28
21.4%		3.6%	0%	0%	0%	28.6%	42.9%	0%	0%	3.6%	100%	
Vandalism	59	10	-	3	16	40	95	2	19	42	286	
	20.6%	3.5%	0%	1%	5.6%	14%	33.2%	0.7%	6.6%	14.7%	100%	
Drug Manufacturing / Sale	Opium or Cocaine	-	-	-	-	-	-	2	-	-	-	2
		0%	0%	0%	0%	0%	0%	100%	0%	0%	0%	100%
	Marijuana	10	1	-	-	2	4	12	-	-	2	31
		32.3%	3.2%	0%	0%	6.5%	12.9%	38.7%	0%	0%	6.5%	100%
	Synthetic Narcotic	-	-	-	-	-	-	-	-	-	-	-
		0%	0%	0%	0%	0%	0%	0%	0%	0%	0%	0%
Nonnarcotic	5	-	-	-	-	2	4	-	-	-	11	
	45.5%	0%	0%	0%	0%	18.2%	36.4%	0%	0%	0%	100%	

State of Hawai'i Race/Ethnicity of Juveniles Arrested for Part II Offenses: 2003 - Continued

Type	Offense	Caucasian	African American	Indian	Chinese	Japanese	Filipino	Hawaiian	Korean	Samoan	Other	Total	
Drug Possession	Opium or Cocaine	5	2	-	-	1	3	7	-	2	-	20	
		25%	10%	0%	0%	5%	15%	35%	0%	10%	0%	100%	
	Marijuana	140	9	1	2	30	63	172	1	9	36	463	
		30.2%	1.9%	0.2%	0.4%	6.5%	13.6%	37.1%	0.2%	1.9%	7.8%	100%	
	Synthetic Narcotic	2	-	-	-	-	-	5	-	-	1	8	
	25%	0%	0%	0%	0%	0%	62.5%	0%	0%	12.5%	100%		
	Nonnarcotic	8	-	-	1	1	5	13	1	-	1	30	
		26.7%	0%	0%	3.3%	3.3%	16.7%	43.3%	3.3%	0%	3.3%	100%	
Gambling	Bookmaking	-	-	-	-	-	-	-	-	-	-	-	
		0%	0%	0%	0%	0%	0%	0%	0%	0%	0%	0%	
	Numbers & Lottery	-	-	-	-	-	-	-	-	-	-	-	-
		0%	0%	0%	0%	0%	0%	0%	0%	0%	0%	0%	0%
	Other	2	1	-	-	1	4	11	-	-	-	19	
10.5%		5.3%	0%	0%	5.3%	21.1%	57.9%	0%	0%	0%	100%		
Alcohol - Related	DUI	31	1	-	-	8	4	21	1	1	5	72	
		43.1%	1.4%	0%	0%	11.1%	5.6%	29.2%	1.4%	1.4%	6.9%	100%	
	Liquor Laws	88	2	-	4	20	31	57	4	8	21	235	
		37.4%	0.9%	0%	1.7%	8.5%	13.2%	24.3%	1.7%	3.4%	8.9%	100%	
Disorderly Conduct	23	2	-	-	2	8	37	-	7	6	85		
	27.1%	2.4%	0%	0%	2.4%	9.4%	43.5%	0%	8.2%	7.1%	100%		

State of Hawai'i Race/Ethnicity of Juveniles Arrested for Part II Offenses: 2003 - Continued

Type	Offense	Caucasian	African American	Indian	Chinese	Japanese	Filipino	Hawaiian	Korean	Samoaan	Other	Total
Other	Offenses Agst. Family/Children	23	2	-	-	9	8	20	3	-	7	72
		31.9%	2.8%	0%	0%	12.5%	11.1%	27.8%	4.2%	0%	9.7%	100%
	Prostitution	2	-	-	-	-	3	5	-	-	1	11
		18.2%	0%	0%	0%	0%	27.3%	45.5%	0%	0%	9.1%	100%
	Suspicion	-	-	-	-	-	-	-	-	-	-	-
		0%	0%	0%	0%	0%	0%	0%	0%	0%	0%	0%
	Vagrancy	-	-	-	-	-	-	-	-	-	-	-
		0%	0%	0%	0%	0%	0%	0%	0%	0%	0%	0%
	Weapons	9	-	-	2	2	10	15	1	4	5	48
		18.8%	0%	0%	4.2%	4.2%	20.8%	31.3%	2.1%	8.3%	10.4%	100%
All Other Offenses	368	35	-	22	79	311	753	27	116	370	2,081	
	17.7%	1.7%	0%	1.1%	3.8%	14.9%	36.2%	1.3%	5.6%	17.8%	100%	
Status	Curfew	174	5	-	2	37	143	196	4	1	51	613
		28.4%	0.8%	0%	0.3%	6.0%	23.3%	32%	0.7%	0.2%	8.3%	100%
	Runaway	916	139	-	50	243	653	1,577	27	202	486	4,293
		21.3%	3.2%	0%	1.2%	5.7%	15.2%	36.7%	6%	4.7%	11.3%	100%
TOTAL		2,086	250	1	95	497	1,476	3,485	79	465	1,198	9,632
Column Percent		21.7%	2.6%	0%	1%	5.2%	15.3%	36.2%	0.8%	4.8%	12.4%	100%

Source: State of Hawai'i Department of the Attorney General, Crime Prevention & Justice Assistance Division

City and County of Honolulu Race/Ethnicity of Adults Arrested for Index Offenses: 2003

Offense / Row %	Caucasian	African American	Indian	Chinese	Japanese	Filipino	Hawaiian	Korean	Samoan	Other	Total
Murder	2	2	-	-	3	5	5	-	1	2	20
	10%	10%	0%	0%	15%	25%	25%	0%	50%	10%	100%
Forcible Rape	22	13	-	1	5	8	15	-	5	12	81
	27.2%	16%	0%	1.2%	6.2%	9.9%	18.5%	0%	6.2%	14.8%	100%
Robbery	42	23	3	2	8	26	52	6	24	29	215
	19.5%	10.7%	1.4%	0.9%	3.7%	12.1%	24.2%	2.8%	11.2%	13.5%	100%
Aggravated Assault	79	26	2	6	14	48	94	8	39	72	388
	20.4%	6.7%	0.5%	1.5%	3.6%	12.4%	24.2%	2.1%	10.1%	18.6%	100%
Burglary	68	10	-	4	14	25	101	2	19	40	283
	24%	3.5%	0%	1.4%	4.9%	8.8%	35.7%	0.7%	6.7%	14.1%	100%
Larceny - Theft	763	109	2	49	202	269	521	35	80	305	2,335
	32.7%	4.7%	0.1%	2.1%	8.7%	11.5%	22.3%	1.5%	3.4%	13.1%	100%
Motor Vehicle Theft	125	13	-	13	40	102	239	9	33	63	637
	19.6%	2%	0%	2%	6.3%	16.0%	37.5%	1.4%	5.2%	9.9%	100%
Arson	3	-	-	-	-	-	2	1	-	-	6
	50%	0%	0%	0%	0%	0%	33.3%	16.7%	0%	0%	100%
TOTAL	1,104	196	7	75	286	483	1,029	61	201	523	3,965
Column Percent	27.8%	4.9%	0.2%	1.9%	7.2%	12.2%	26.0%	1.5%	5.1%	13.2%	100%

Source: State of Hawai'i Attorney General, Crime Prevention & Justice Assistance Division

City and County of Honolulu Race/Ethnicity of Juveniles Arrested for Index Offenses: 2003

Offense / Row %	Caucasian	African American	Indian	Chinese	Japanese	Filipino	Hawaiian	Korean	Samoan	Other	Total
Murder	-	-	-	-	-	1	1	-	-	-	2
	0%	0%	0%	0%	0%	50%	50%	0%	0%	0%	100%
Forcible Rape	3	4	-	-	-	1	4	-	-	1	13
	23.1%	30.8%	0%	0%	0%	7.7%	30.8%	0%	0%	7.7%	100%
Robbery	8	4	-	1	1	10	44	1	24	14	107
	7.5%	3.7%	0%	0.9%	0.9%	9.3%	41.1%	0.9%	22.4%	13.1%	100%
Aggravated Assault	8	4	-	2	4	3	29	1	15	14	80
	10.0%	5.0%	0.0%	2.5%	5.0%	3.8%	36.3%	1.3%	18.8%	17.5%	100%
Burglary	16	3	-	-	1	14	45	-	11	20	110
	14.5%	2.7%	0%	0%	0.9%	12.7%	40.9%	0%	10%	18.2%	100%
Larceny - Theft	184	28	-	24	76	174	336	14	73	129	1,038
	17.7%	2.7%	0%	2.3%	7.3%	16.8%	32.4%	1.3%	7%	12.4%	100%
Motor Vehicle Theft	9	3	-	-	4	11	49	1	2	6	85
	10.6%	3.5%	0%	0%	4.7%	12.9%	57.6%	1.2%	2.4%	7.1%	100%
Arson	-	1	-	-	-	2	2	-	-	-	5
	0%	20%	0%	0%	0%	40%	40%	0%	0%	0%	100%
TOTAL	228	47	-	27	86	216	510	17	125	184	1,440
Column Percent	15.8%	3.3%	0%	1.9%	6.0%	15.0%	35.4%	1.2%	8.7%	12.8%	100%

Source: State of Hawaii Attorney General, Crime Prevention & Justice Assistance Division

City & County of Honolulu Race/Ethnicity of Adults Arrested for Part II Offenses: 2003

Type	Offense	Caucasian	African American	Indian	Chinese	Japanese	Filipino	Hawaiian	Korean	Samoaan	Other	Total
Violent	Negligent Manslaughter	1	-	-	-	-	-	2	-	-	3	6
		16.7%	0%	0%	0%	0.0%	0%	33.3%	0%	0%	50%	100%
	Other Assault	513	125	4	37	104	212	485	25	133	352	1,990
		25.8%	6.3%	0.2%	1.9%	5.2%	10.7%	24.4%	1.3%	6.7%	17.7%	100%
	Sex Offenses	48	17	1	3	24	28	30	8	12	28	199
24.1%		8.5%	0.5%	1.5%	12.1%	14.1%	15.1%	4.0%	6.0%	14.1%	100%	
Property - Related	Forgery	41	17	1	10	27	60	69	4	10	30	269
		15.2%	6.3%	0.4%	3.7%	10%	22.3%	25.7%	1.5%	3.7%	11.2%	100%
	Fraud	47	7	-	29	19	38	46	11	2	19	218
		21.6%	3.2%	0%	13.3%	8.7%	17.4%	21.1%	5%	0.9%	8.7%	100%
	Embezzlement	6	1	-	-	4	6	2	-	-	3	22
		27%	4.5%	0%	0%	18.2%	27.3%	9.1%	0%	0%	13.6%	100%
	Stolen Property	35	3	-	1	16	16	46	2	4	18	141
24.8%		2.1%	0%	0.7%	11.3%	11.3%	32.6%	1.4%	2.8%	12.8%	100%	
Vandalism	86	11	-	5	19	29	68	5	24	49	296	
	29.1%	3.7%	0%	2%	6.4%	9.8%	23%	1.7%	8.1%	16.6%	100%	
Drug Manufacturing / Sale	Opium or Cocaine	8	11	-	1	6	10	18	1	5	9	69
		11.6%	15.9%	0%	1.4%	8.7%	14.5%	26.1%	1.4%	7.2%	13%	100%
	Marijuana	4	4	-	3	1	2	5	-	-	-	19
		21%	21.1%	0%	15.8%	5.3%	10.5%	26.3%	0%	0%	0%	100%
	Synthetic Narcotic	4	1	-	1	4	4	10	1	2	8	35
		11.4%	2.9%	0%	2.9%	11.4%	11.4%	28.6%	2.9%	5.7%	22.9%	100%
Nonnarcotic	16	6	-	3	11	10	22	-	2	12	82	
	19.5%	7.3%	0%	3.7%	13.4%	12.2%	26.8%	0%	2.4%	14.6%	100%	

City & County of Honolulu Race/Ethnicity of Adults Arrested for Part II Offenses: 2003 - Continued

Type	Offense	Caucasian	African American	Indian	Chinese	Japanese	Filipino	Hawaiian	Korean	Samoan	Other	Total	
Drug Possession	Opium or Cocaine	79	25	1	3	32	28	62	5	26	41	302	
		26.2%	8.3%	0.3%	1.0%	10.6%	9.3%	20.5%	1.7%	8.6%	13.6%	100%	
	Marijuana	84	15	-	8	30	43	80	10	17	34	321	
		26.2%	4.7%	0%	2.5%	9.3%	13%	25%	3.1%	5.3%	10.6%	100%	
	Synthetic Narcotic	27	4	-	2	9	21	33	1	5	14	116	
		23.3%	3.4%	0%	1.7%	8%	18.1%	28.4%	0.9%	4.3%	12.1%	100%	
Nonnarcotic		84	2	-	9	41	110	130	5	13	38	432	
		19.4%	0.5%	0%	2.1%	9.5%	25.5%	30.1%	1.2%	3%	8.8%	100%	
Gambling		-	-	-	-	-	-	-	-	-	-	-	
	Bookmaking	0%	0%	0%	0%	0%	0%	0%	0%	0%	0%	0%	
	Numbers & Lottery	-	-	-	-	-	-	-	-	-	-	-	-
		0%	0%	0%	0%	0%	0%	0%	0%	0%	0%	0%	0%
	Other	1	-	-	3	1	4	1	1	6	25	42	
	2.4%	0%	0%	7.1%	2.4%	9.5%	2.4%	2.4%	14.3%	59.5%	100%		
Alcohol - Re-lated		697	70	1	62	304	235	294	69	86	307	2,125	
	DUI	32.8%	3.3%	0%	2.9%	14.3%	11.1%	13.8%	3.2%	4%	14.4%	100%	
	Liquor Laws	163	25	-	11	28	37	110	5	44	133	556	
		29.3%	4.5%	0%	2%	5%	6.7%	19.8%	0.9%	7.9%	23.9%	100%	
	Disorderly Conduct	88	20	-	2	12	16	64	5	26	50	283	
	31.1%	7.1%	0%	0.7%	4.2%	5.7%	22.6%	1.8%	9.2%	17.7%	100%		

City & County of Honolulu Race/Ethnicity of Adults Arrested for Part II Offenses: 2003 - Continued

Type	Offense	Caucasian	African American	Indian	Chinese	Japanese	Filipino	Hawaiian	Korean	Samoaan	Other	Total	
Other	Offenses Agst. Family/Children	169	39	-	19	55	119	200	16	56	124	797	
		21.2%	4.9%	0%	2.4%	6.9%	15%	25.1%	2%	7%	15.6%	100%	
	Prostitution	93	34	-	16	22	34	31	50	11	47	338	
		27.5%	10.1%	0%	4.7%	6.5%	10.1%	9.2%	14.8%	3.3%	13.9%	100%	
	Suspicion	-	-	-	-	-	-	-	-	-	-	-	-
		0%	0%	0%	0%	0%	0%	0%	0%	0%	0%	0%	0%
	Vagrancy	-	-	-	-	-	-	-	-	-	-	-	-
		0%	0%	0%	0%	0%	0%	0%	0%	0%	0%	0%	0%
	Weapons	51	8	-	3	14	29	28	3	11	26	173	
		29.5%	4.6%	0%	1.7%	8.1%	16.8%	16.2%	1.7%	6.4%	15%	100%	
All Other Offenses	4,140	674	17	289	878	1,868	4,037	156	671	2,847	15,577		
	26.6%	4.3%	0.1%	1.9%	5.6%	12%	25.9%	1%	4.3%	18.3%	100%		
TOTAL		6,485	1,119	25	520	1,661	2,959	5,873	383	1,166	4,217	24,408	
Column Percent		26.6%	4.6%	0.1%	2.1%	6.8%	12.1%	24.1%	1.6%	4.8%	17.3%	100%	

Source: State of Hawai'i Department of the Attorney General, Crime Prevention & Justice Assistance Division

City & County of Honolulu Race/Ethnicity of Juveniles Arrested for Part II Offenses: 2003

Type	Offense	Caucasian	African American	Indian	Chinese	Japanese	Filipino	Hawaiian	Korean	Samoan	Other	Total
Violent	Negligent Manslaughter	-	-	-	-	1	-	-	-	-	-	1
		0%	0%	0%	0%	100%	0%	0%	0%	0%	0%	100%
	Other Assault	99	35	-	5	23	107	336	7	82	109	803
		12.3%	4.4%	0%	0.6%	2.9%	13.3%	41.8%	0.9%	10.2%	13.6%	100%
	Sex Offenses	10	3	-	-	3	12	16	1	11	20	76
		13.2%	3.9%	0%	0%	3.9%	15.8%	21.1%	1.3%	14.5%	26.3%	100%
Property - Related	Forgery	1	-	-	-	-	2	3	-	-	3	9
		11.1%	0%	0%	0.0%	0%	22.2%	33.3%	0%	0%	33.3%	100%
	Fraud	4	1	-	-	1	1	5	-	-	3	15
		26.7%	6.7%	0%	0%	6.7%	6.7%	33.3%	0%	0%	20%	100%
	Embezzlement	-	-	-	-	-	-	-	-	-	-	-
		0%	0%	0%	0%	0%	0%	0%	0%	0%	0%	0%
Stolen Property	6	1	-	-	-	8	12	-	-	1	28	
	21.4%	3.6%	0%	0%	0%	28.6%	42.9%	0%	0%	3.6%	100%	
Vandalism	29	8	-	2	13	21	69	2	19	29	192	
	15.1%	4.2%	0%	1%	6.8%	10.9%	35.9%	1.0%	9.9%	15.1%	100%	
Drug Manufacturing / Sale	Opium or Cocaine	-	-	-	-	-	-	-	-	-	-	-
		0%	0%	0%	0%	0%	0%	0%	0%	0%	0%	0%
	Marijuana	2	-	-	-	1	3	3	-	-	2	11
		18.2%	0%	0%	0%	9.1%	27.3%	27.3%	0%	0%	18.2%	100%
	Synthetic Narcotic	-	-	-	-	-	-	-	-	-	-	-
		0%	0%	0%	0%	0%	0%	0%	0%	0%	0%	0%
Nonnarcotic	1	-	-	-	-	1	1	-	-	-	3	
	33.3%	0%	0%	0%	0%	33.3%	33.3%	0%	0%	0%	100%	

City & County of Honolulu Race/Ethnicity of Juveniles Arrested for Part II Offenses: 2003 - Continued

Type	Offense	Caucasian	African American	Indian	Chinese	Japanese	Filipino	Hawaiian	Korean	Samoaan	Other	Total
Drug Possession	Opium or Cocaine	3	1	-	-	1	1	4	-	2	-	12
		25%	8.3%	0%	0%	8.3%	8%	33%	0%	16.7%	0%	100%
	Marijuana	38	4	1	2	17	25	80	1	8	20	196
		19.4%	2%	0.5%	1%	8.7%	12.8%	40.8%	0.5%	4.1%	10.2%	100%
	Synthetic Narcotic	2	-	-	-	-	-	5	-	-	1	8
	25%	0%	0%	0%	0%	0%	62.5%	0%	0%	12.5%	100%	
	Nonnarcotic	2	-	-	1	1	2	7	1	-	1	15
		13.3%	0%	0%	6.7%	6.7%	13.3%	46.7%	6.7%	0%	6.7%	100%
Gambling	Bookmaking	-	-	-	-	-	-	-	-	-	-	-
		0%	0%	0%	0%	0%	0%	0%	0%	0%	0%	0%
	Numbers & Lottery	-	-	-	-	-	-	-	-	-	-	-
		0%	0%	0%	0%	0%	0%	0%	0%	0%	0%	0%
	Other	-	1	-	-	1	1	6	-	-	-	9
0%		11.1%	0%	0%	11.1%	11.1%	66.7%	0%	0%	0%	100%	
Alcohol - Related	DUI	8	-	-	-	4	2	7	1	1	3	26
		30.8%	0%	0%	0%	15.4%	7.7%	26.9%	3.8%	3.8%	11.5%	100%
	Liquor Laws	33	1	-	3	3	15	33	4	7	12	111
		29.7%	0.9%	0%	2.7%	2.7%	13.5%	29.7%	3.6%	6.3%	10.8%	100%
Disorderly Conduct	3	2	-	-	1	1	9	-	6	4	26	
	11.5%	7.7%	0%	0%	3.8%	3.8%	34.6%	0%	23.1%	15.4%	100%	

City & County of Honolulu Race/Ethnicity of Juveniles Arrested for Part II Offenses: 2003 - Continued

Type	Offense	Caucasian	African American	Indian	Chinese	Japanese	Filipino	Hawaiian	Korean	Samoaan	Other	Total
Other	Offenses Agst. Family/Children	21	2	-	-	9	8	20	3	-	6	69
		30.4%	2.9%	0%	0%	13%	11.6%	29%	4.3%	0%	8.7%	100%
	Prostitution	2	-	-	-	-	3	5	-	-	1	11
		18.2%	0%	0%	0%	0%	27.3%	45.5%	0%	0%	9.1%	100%
	Suspicion	-	-	-	-	-	-	-	-	-	-	-
		0%	0%	0%	0%	0%	0%	0%	0%	0%	0%	0%
	Vagrancy	-	-	-	-	-	-	-	-	-	-	-
		0%	0%	0%	0%	0%	0%	0%	0%	0%	0%	0%
	Weapons	5	-	-	2	1	8	11	1	4	3	35
		14.3%	0%	0%	5.7%	2.9%	22.9%	31.4%	2.9%	11.4%	8.6%	100%
All Other Offenses	225	30	-	22	54	248	573	26	116	326	1,620	
	13.9%	1.9%	0%	1.4%	3.3%	15.3%	35.4%	1.6%	7.2%	20.1%	100%	
Status	Curfew	34	3	-	-	10	28	26	3	-	39	143
		23.8%	2.1%	0%	0%	7%	19.6%	18.2%	2.1%	0%	27.3%	100%
	Runaway	567	115	-	46	175	502	1,259	26	198	401	3,289
	17.2%	3.5%	0%	1.4%	5.3%	15.3%	38.3%	0.8%	6%	12.2%	100%	
TOTAL		1,095	207	1	83	319	999	2,490	76	454	984	6,708
Column Percent		16.3%	3.1%	0%	1.2%	4.8%	14.9%	37.1%	1.1%	6.8%	14.7%	100%

Source: State of Hawai'i Department of the Attorney General, Crime Prevention & Justice Assistance Division

Kaua'i County Race/Ethnicity of Adults Arrested for Index Offenses: 2003

Offense / Row %	Caucasian	African American	Indian	Chinese	Japanese	Filipino	Hawaiian	Korean	Samoaan	Other	Total
	-	-	-	-	-	-	-	-	-	-	-
Murder	0%	0%	0%	0%	0%	0%	0%	0%	0%	0%	0%
	5	-	-	-	-	1	1	-	-	-	7
Forcible Rape	71.4%	0%	0%	0%	0%	14.3%	14.3%	0%	0%	0%	100%
	3	-	-	-	-	-	5	-	-	1	9
Robbery	33.3%	0%	0%	0%	0%	0%	55.6%	0%	0%	11.1%	100%
	25	3	-	1	8	10	16	-	-	6	69
Aggravated Assault	36.2%	4.3%	0%	1.4%	11.6%	14.5%	23.2%	0%	0%	8.7%	100%
	21	-	-	-	2	9	9	-	-	1	42
Burglary	50%	0%	0%	0%	4.8%	21.4%	21.4%	0%	0%	2.4%	100%
	91	-	-	2	7	17	39	-	1	12	169
Larceny - Theft	53.8%	0%	0%	1.2%	4.1%	10.1%	23.1%	0%	0.6%	7.1%	100%
	10	-	1	-	-	8	13	-	-	2	34
Motor Vehicle Theft	29.4%	0%	2.9%	0%	0%	23.5%	38.2%	0%	0%	5.9%	100%
	-	-	-	-	-	-	-	-	-	-	-
Arson	0%	0%	0%	0%	0%	0%	0%	0%	0%	0%	0%
TOTAL	155	3	1	3	17	45	83	-	1	22	330
Column Percent	47%	0.9%	0.3%	0.9%	5.2%	13.6%	25.2%	0%	0.3%	6.7%	100%

Source: State of Hawai'i Attorney General, Crime Prevention & Justice Assistance Division

Kaua'i County Race/Ethnicity of Juveniles Arrested for Index Offenses: 2003

Offense / Row %	Caucasian	African American	Indian	Chinese	Japanese	Filipino	Hawaiian	Korean	Samoan	Other	Total
Murder	-	-	-	-	-	-	-	-	-	-	-
	0%	0%	0%	0%	0%	0%	0%	0%	0%	0%	0%
Forcible Rape	-	-	-	-	-	-	-	-	-	-	-
	0%	0%	0%	0%	0%	0%	0%	0%	0%	0%	0%
Robbery	-	-	-	-	-	-	-	-	-	-	-
	0%	0%	0%	0%	0%	0%	0%	0%	0%	0%	0%
Aggravated Assault	2	-	-	-	1	2	5	-	-	-	10
	20%	0%	0%	0%	10%	20%	50%	0%	0%	0%	100%
Burglary	17	-	-	-	1	3	18	-	1	1	41
	41.5%	0%	0%	0%	2.4%	7.3%	43.9%	0%	2.4%	2.4%	100%
Larceny - Theft	32	1	-	-	3	6	34	-	-	6	82
	39.0%	1.2%	0%	0%	3.7%	7.3%	41.5%	0%	0%	7.3%	100%
Motor Vehicle Theft	16	1	-	-	3	14	14	-	-	1	49
	32.7%	2%	0%	0%	6.1%	28.6%	28.6%	0%	0%	2%	100%
Arson	-	-	-	-	-	-	-	-	-	-	-
	0%	0%	0%	0%	0%	0%	0%	0%	0%	0%	0%
TOTAL	67	2	-	-	8	25	71	-	1	8	182
Column Percent	36.8%	1.1%	0%	0%	4.4%	13.7%	39%	0%	0.5%	4.4%	100%

Source: State of Hawai'i Attorney General, Crime Prevention & Justice Assistance Division

Kaua'i County Race/Ethnicity of Adults Arrested for Part II Offenses: 2003

Type	Offense	Caucasian	African American	Indian	Chinese	Japanese	Filipino	Hawaiian	Korean	Samoaan	Other	Total
Violent	Negligent Manslaughter	-	-	-	-	-	-	-	-	-	-	-
		0%	0%	0%	0%	0%	0%	0%	0%	0%	0%	0%
	Other Assault	149	9	-	4	26	81	150	-	5	25	449
		33.2%	2%	0%	0.9%	5.8%	18%	33.4%	0%	1.1%	5.6%	100%
	Sex Offenses	28	-	-	2	-	7	4	-	-	2	43
65.1%		0%	0%	4.7%	0%	16.3%	9.3%	0%	0%	4.7%	100%	
Property - Related	Forgery	4	-	-	-	2	5	7	-	-	-	18
		22.2%	0.0%	0.0%	0.0%	11%	27.8%	38.9%	0.0%	0.0%	0.0%	100%
	Fraud	16	-	-	-	1	15	15	-	-	3	50
		32%	0%	0%	0%	2%	30%	30%	0%	0%	6%	100%
	Embezzlement	1	-	-	-	-	1	1	-	-	-	3
		33%	0%	0%	0%	0%	33.3%	33.3%	0%	0%	0%	100%
	Stolen Property	-	-	-	-	-	-	-	-	-	-	-
0%		0%	0%	0%	0%	0%	0%	0%	0%	0%	0%	
Vandalism	23	2	-	-	5	17	17	1	2	3	70	
	32.9%	2.9%	0%	0%	7.1%	24.3%	24%	1.4%	2.9%	4.3%	100%	
Drug Manufacturing / Sale	Opium or Cocaine	-	-	-	-	-	-	-	-	-	-	-
		0%	0%	0%	0%	0%	0%	0%	0%	0%	0%	0%
	Marijuana	-	-	-	-	-	-	-	-	-	-	-
		0%	0%	0%	0%	0%	0%	0%	0%	0%	0%	0%
	Synthetic Narcotic	-	-	-	-	-	-	-	-	-	-	-
		0%	0%	0%	0%	0%	0%	0%	0%	0%	0%	0%
Nonnarcotic	-	-	-	-	-	-	-	-	-	-	-	
	0%	0%	0%	0%	0%	0%	0%	0%	0%	0%	0%	

Kaua'i County Race/Ethnicity of Adults Arrested for Part II Offenses: 2003 - Continued

Type	Offense	Caucasian	African American	Indian	Chinese	Japanese	Filipino	Hawaiian	Korean	Samoaan	Other	Total	
Drug Possession	Opium or Cocaine	1	-	-	-	-	-	-	-	-	-	1	
		100%	0%	0%	0%	0%	0%	0%	0%	0%	0%	100%	
	Marijuana	34	1	-	1	2	-	14	-	-	2	54	
		63%	1.9%	0%	1.9%	3.7%	0%	25.9%	0%	0%	3.7%	100%	
	Synthetic Narcotic	-	-	-	-	-	-	-	-	-	-	-	-
		0%	0%	0%	0%	0%	0%	0%	0%	0%	0%	0%	
Nonnarcotic		31	-	-	-	10	33	31	-	-	9	114	
		27.2%	0%	0%	0%	8.8%	28.9%	27.2%	0%	0%	7.9%	100%	
Gambling		-	-	-	-	-	-	-	-	-	-	-	
	Bookmaking	0%	0%	0%	0%	0%	0%	0%	0%	0%	0%	0%	
	Numbers & Lottery	-	-	-	-	-	-	-	-	-	-	-	-
		0%	0%	0%	0%	0%	0%	0%	0%	0%	0%	0%	
	Other	-	-	-	-	-	-	-	-	-	-	-	
	0%	0%	0%	0%	0%	0%	0%	0%	0%	0%	0%		
Alcohol - Related		114	3	2	3	20	24	29	-	-	17	212	
	DUI	53.8%	1.4%	0.9%	1.4%	9.4%	11.3%	13.7%	0%	0%	8%	100%	
		35	-	-	-	6	23	6	-	1	4	75	
	Liquor Laws	46.7%	0%	0%	0%	8%	30.7%	8%	0%	1.3%	5.3%	100%	
Disorderly Conduct		13	-	-	-	2	2	3	-	-	-	20	
		65%	0%	0%	0%	10%	10%	15%	0%	0%	0%	100%	

Kaua'i County Race/Ethnicity of Adults Arrested for Part II Offenses: 2003 - Continued

Type	Offense	Caucasian	African American	Indian	Chinese	Japanese	Filipino	Hawaiian	Korean	Samoaan	Other	Total	
Other	Offenses Agst. Family/Children	7	-	-	-	-	3	3	-	1	-	14	
		50%	0%	0%	0%	0%	21.4%	21.4%	0%	7.1%	0%	100%	
	Prostitution	-	-	-	-	-	-	-	-	-	-	-	-
		0%	0%	0%	0%	0%	0%	0%	0%	0%	0%	0%	0%
	Suspicion	-	-	-	-	-	-	-	-	-	-	-	-
		0%	0%	0%	0%	0%	0%	0%	0%	0%	0%	0%	0%
	Vagrancy	-	-	-	-	-	-	-	-	-	-	-	-
		0%	0%	0%	0%	0%	0%	0%	0%	0%	0%	0%	0%
	Weapons	3	-	-	1	1	4	11	-	-	-	-	20
15%		0%	0%	5%	5%	20%	55%	0%	0%	0%	0%	100%	
All Other Offenses	495	12	6	16	80	227	366	1	7	62	1,272		
	38.9%	0.9%	0.5%	1.3%	6.3%	17.8%	28.8%	0.1%	0.6%	4.9%	100%		
TOTAL		954	27	8	27	155	442	657	2	16	127	2,415	
Column Percent		39.5%	1.1%	0.3%	1.1%	6.4%	18.3%	27.2%	0.1%	0.7%	5.3%	100%	

Source: State of Hawai'i Department of the Attorney General, Crime Prevention & Justice Assistance Division

Kaua'i County Race/Ethnicity of Juveniles Arrested for Part II Offenses: 2003

Type	Offense	Caucasian	African American	Indian	Chinese	Japanese	Filipino	Hawaiian	Korean	Samoaan	Other	Total
Violent	Negligent Manslaughter	-	-	-	-	-	-	-	-	-	-	-
		0%	0%	0%	0%	0%	0%	0%	0%	0%	0%	0%
	Other Assault	48	1	-	1	12	26	53	-	1	1	143
		33.6%	0.7%	0%	0.7%	8.4%	18.2%	37.1%	0%	0.7%	0.7%	100%
	Sex Offenses	1	-	-	-	-	3	2	-	-	1	7
14.3%		0%	0%	0%	0%	42.9%	28.6%	0%	0%	14.3%	100%	
Property - Related	Forgery	1	-	-	-	-	-	-	-	-	-	1
		100%	0%	0%	0%	0%	0%	0%	0%	0%	0%	100%
	Fraud	-	-	-	-	-	-	-	-	-	-	-
		0%	0%	0%	0%	0%	0%	0%	0%	0%	0%	0%
	Embezzlement	1	-	-	-	-	1	1	-	-	-	3
		33.3%	0%	0%	0%	0%	33.3%	33.3%	0%	0%	0%	100%
	Stolen Property	-	-	-	-	-	-	-	-	-	-	-
0%		0%	0%	0%	0%	0%	0%	0%	0%	0%	0%	
Vandalism	9	2	-	1	2	3	13	-	-	1	31	
	29%	6.5%	0%	3.2%	6.5%	9.7%	41.9%	0%	0%	3.2%	100%	
Drug Manufacturing / Sale	Opium or Cocaine	-	-	-	-	-	-	-	-	-	-	-
		0%	0%	0%	0%	0%	0%	0%	0%	0%	0%	0%
	Marijuana	-	-	-	-	-	-	-	-	-	-	-
		0%	0%	0%	0%	0%	0%	0%	0%	0%	0%	0%
	Synthetic Narcotic	-	-	-	-	-	-	-	-	-	-	-
		0%	0%	0%	0%	0%	0%	0%	0%	0%	0%	0%
	Nonnarcotic	-	-	-	-	-	-	-	-	-	-	-
0%		0%	0%	0%	0%	0%	0%	0%	0%	0%	0%	

Kaua'i County Race/Ethnicity of Juveniles Arrested for Part II Offenses: 2003 - Continued

Type	Offense	Caucasian	African American	Indian	Chinese	Japanese	Filipino	Hawaiian	Korean	Samoaan	Other	Total
Drug Possession	Opium or Cocaine	-	-	-	-	-	-	-	-	-	-	-
		0%	0%	0%	0%	0%	0%	0%	0%	0%	0%	0%
		21	-	-	-	7	15	22	-	-	1	66
	Marijuana	31.8%	0%	0%	0%	10.6%	22.7%	33.3%	0%	0%	1.5%	100%
	Synthetic Narcotic	-	-	-	-	-	-	-	-	-	-	-
		0%	0%	0%	0%	0%	0%	0%	0%	0%	0%	0%
	Nonnarcotic	-	-	-	-	-	-	-	-	-	-	-
		0%	0%	0%	0%	0%	0%	0%	0%	0%	0%	0%
Gambling		-	-	-	-	-	-	-	-	-	-	-
	Bookmaking	0%	0%	0%	0%	0%	0%	0%	0%	0%	0%	0%
	Numbers & Lottery	-	-	-	-	-	-	-	-	-	-	-
		0%	0%	0%	0%	0%	0%	0%	0%	0%	0%	0%
		2	-	-	-	-	2	5	-	-	-	9
Other	22.2%	0%	0%	0%	0%	22.2%	55.6%	0%	0%	0%	100%	
Alcohol - Related		4	-	-	-	1	-	1	-	-	-	6
	DUI	66.7%	0%	0%	0%	16.7%	0%	16.7%	0%	0%	0%	100%
		7	-	-	-	6	10	3	-	-	1	27
	Liquor Laws	25.9%	0%	0%	0%	22.2%	37%	11.1%	0%	0%	3.7%	100%
	Disorderly Conduct	1	-	-	-	-	-	5	-	1	-	7
	14.3%	0%	0%	0%	0%	0%	71.4%	0%	14.3%	0%	100%	

Kaua'i County Race/Ethnicity of Juveniles Arrested for Part II Offenses: 2003 - Continued

Type	Offense	Caucasian	African American	Indian	Chinese	Japanese	Filipino	Hawaiian	Korean	Samoaan	Other	Total	
Other	Offenses Agst. Family/Children	1	-	-	-	-	-	-	-	-	1	2	
		50%	0%	0%	0%	0%	0%	0%	0%	0%	50%	100%	
	Prostitution	-	-	-	-	-	-	-	-	-	-	-	-
		0%	0%	0%	0%	0%	0%	0%	0%	0%	0%	0%	0%
	Suspicion	-	-	-	-	-	-	-	-	-	-	-	-
		0%	0%	0%	0%	0%	0%	0%	0%	0%	0%	0%	0%
	Vagrancy	-	-	-	-	-	-	-	-	-	-	-	-
		0%	0%	0%	0%	0%	0%	0%	0%	0%	0%	0%	0%
Weapons	2	-	-	-	-	1	1	-	-	-	-	4	
	50%	0%	0%	0%	0%	25%	25%	0%	0%	0%	0%	100%	
All Other Offenses	27	-	-	-	-	7	28	38	-	-	5	105	
	25.7%	0%	0%	0%	0%	6.7%	26.7%	36.2%	0%	0%	4.8%	100%	
Status	Curfew	99	1	-	2	23	74	133	1	1	5	339	
		29.2%	0.3%	0%	0.6%	6.8%	21.8%	39.2%	0.3%	0.3%	1.5%	100%	
	Runaway	68	1	-	2	38	48	56	-	-	6	219	
		31.1%	0.5%	0%	0.9%	17.4%	21.9%	25.6%	0%	0%	2.7%	100%	
TOTAL		292	5	-	6	97	211	332	1	3	22	969	
Column Percent		30.1%	0.5%	0%	0.6%	10%	21.8%	34.3%	0.1%	0.3%	2.3%	100%	

Source: State of Hawai'i Department of the Attorney General, Crime Prevention & Justice Assistance Division

Maui County Race/Ethnicity of Adults Arrested for Index Offenses: 2003

Offense / Row %	Caucasian	African American	Indian	Chinese	Japanese	Filipino	Hawaiian	Korean	Samoaan	Other	Total
Murder	-	-	-	-	-	-	-	-	-	1	1
	0%	0%	0%	0%	0%	0%	0%	0%	0%	100%	100%
Forcible Rape	3	-	-	-	-	2	1	-	-	3	9
	33.3%	0%	0%	0%	0%	22.2%	11.1%	0%	0%	33.3%	100%
Robbery	24	1	-	1	1	4	33	-	-	5	69
	34.8%	1.4%	0%	1.4%	1.4%	5.8%	47.8%	0%	0%	7.2%	100%
Aggravated Assault	47	4	-	3	1	15	30	-	1	8	109
	43.1%	3.7%	0%	2.8%	0.9%	13.8%	27.5%	0%	0.9%	7.3%	100%
Burglary	54	4	-	2	1	21	31	-	-	10	123
	43.9%	3.3%	0%	1.6%	0.8%	17.1%	25.2%	0%	0%	8.1%	100%
Larceny - Theft	168	2	-	3	17	50	95	3	3	32	373
	45%	0.5%	0%	0.8%	4.6%	13.4%	25.5%	0.8%	0.8%	8.6%	100%
Motor Vehicle Theft	87	1	-	1	5	16	62	-	3	17	192
	45.3%	0.5%	0%	0.5%	2.6%	8.3%	32.3%	0%	1.6%	8.9%	100%
Arson	3	-	-	-	-	-	-	-	-	-	3
	100%	0%	0%	0%	0%	0%	0%	0%	0%	0%	100%
TOTAL	386	12	-	10	25	108	252	3	7	76	879
Column Percent	43.9%	1.4%	0%	1.1%	2.8%	12.3%	28.7%	0.3%	0.8%	8.6%	100%

Source: State of Hawai'i Department of the Attorney General, Crime Prevention & Justice Division.

Maui County Race/Ethnicity of Juveniles Arrested for Index Offenses: 2003

Offense / Row %	Caucasian	African American	Indian	Chinese	Japanese	Filipino	Hawaiian	Korean	Samoaan	Other	Total
	-	-	-	-	-	-	-	-	-	-	-
Murder	0%	0%	0%	0%	0%	0%	0%	0%	0%	0%	0%
	1	-	-	-	-	-	-	-	-	-	1
Forcible Rape	100%	0%	0%	0%	0%	0%	0%	0%	0%	0%	100%
	3	1	-	-	-	1	8	-	-	4	17
Robbery	17.6%	5.9%	0%	0%	0%	5.9%	47.1%	0%	0%	23.5%	100%
	-	-	-	-	-	5	7	-	-	3	15
Aggravated Assault	0%	0%	0%	0%	0%	33.3%	46.7%	0%	0%	20%	100%
	10	-	-	-	-	4	15	-	-	-	29
Burglary	34.5%	0%	0%	0%	0%	13.8%	51.7%	0%	0%	0%	100%
	39	1	-	-	2	14	34	-	-	8	98
Larceny - Theft	39.8%	1%	0%	0%	2%	14.3%	34.7%	0%	0%	8.2%	100%
	13	-	-	-	4	14	12	-	-	4	47
Motor Vehicle Theft	27.7%	0%	0%	0%	8.5%	29.8%	25.5%	0%	0%	8.5%	100%
	1	-	-	-	-	-	-	-	-	-	1
Arson	100%	0%	0%	0%	0%	0%	0%	0%	0%	0%	100%
TOTAL	67	2	-	-	6	38	76	-	-	19	208
Column Percent	32.2%	1%	0%	0%	2.9%	18.3%	36.5%	0%	0%	9.1%	100%

Source: State of Hawai'i Attorney General, Crime Prevention & Justice Assistance Division

Maui County Race/Ethnicity of Adults Arrested for Part II Offenses: 2003

Type	Offense	Caucasian	African American	Indian	Chinese	Japanese	Filipino	Hawaiian	Korean	Samoaan	Other	Total
Violent	Negligent Manslaughter	-	-	-	-	-	-	-	-	-	-	-
		0%	0%	0%	0%	0%	0%	0%	0%	0%	0%	0%
	Other Assault	198	11	-	2	14	82	139	6	3	55	510
		38.8%	2.2%	0%	0.4%	2.7%	16.1%	27.3%	1.2%	0.6%	10.8%	100%
	Sex Offenses	8	-	-	-	6	5	1	-	-	1	21
38.1%		0%	0%	0%	28.6%	23.8%	4.8%	0%	0%	4.8%	100%	
Property - Related	Forgery	12	-	1	1	4	11	8	1	-	10	48
		25%	0%	2.1%	2.1%	8.3%	22.9%	16.7%	2.1%	0%	20.8%	100%
	Fraud	37	2	-	-	5	6	11	-	-	3	64
		57.8%	3.1%	0%	0%	7.8%	9.4%	17.2%	0%	0%	4.7%	100%
	Embezzlement	5	-	1	-	1	6	2	-	-	-	15
		33%	0%	6.7%	0%	6.7%	40%	13.3%	0%	0%	0%	100%
	Stolen Property	1	-	-	-	2	2	2	-	-	-	7
14.3%		0%	0%	0%	28.6%	28.6%	28.6%	0%	0%	0%	100%	
Vandalism	19	4	-	-	3	12	17	-	-	4	59	
	32.2%	6.8%	0%	0%	5.1%	20.3%	28.8%	0%	0%	6.8%	100%	
Drug Manufacturing / Sale	Opium or Cocaine	5	-	-	-	-	-	-	-	-	2	7
		71.4%	0%	0%	0%	0%	0%	0%	0%	0%	28.6%	100%
	Marijuana	20	1	-	2	2	4	20	-	-	1	50
		40%	2%	0%	4%	4%	8%	40%	0%	0%	2%	100%
	Synthetic Narcotic	9	1	-	-	2	-	1	-	-	1	14
		64.3%	7.1%	0%	0%	14.3%	0%	7.1%	0%	0%	7.1%	100%
Nonnarcotic	13	-	-	1	1	12	10	4	-	4	45	
	28.9%	0%	0%	2.2%	2.2%	26.7%	22.2%	8.9%	0%	8.9%	100%	

Maui County Race/Ethnicity of Adults Arrested for Part II Offenses: 2003 - Continued

Type	Offense	Caucasian	African American	Indian	Chinese	Japanese	Filipino	Hawaiian	Korean	Samoan	Other	Total	
Drug Possession	Opium or Cocaine	13 61.9%	- 0%	- 0%	- 0%	1 4.8%	1 4.8%	3 14.3%	- 0%	- 0%	3 14.3%	21 100%	
	Marijuana	84 53.8%	5 3.2%	1 0.6%	- 0%	3 1.9%	13 8.3%	33 21.2%	1 0.6%	2 1.3%	14 9%	156 100%	
	Synthetic Narcotic	5 23.8%	- 0%	- 0%	- 0%	2 9.5%	10 47.6%	4 19%	- 0%	- 0%	- 0%	21 100%	
	Nonnarcotic	102 32.4%	7 2.2%	- 0%	1 0.3%	24 7.6%	82 26%	80 25.4%	- 0%	1 0%	18 5.7%	315 100%	
			-	-	-	-	-	-	-	-	-	-	-
		Bookmaking	0%	0%	0%	0%	0%	0%	0%	0%	0%	0%	0%
Gambling	Numbers & Lottery	- 0%	- 0%	- 0%	- 0%	- 0%	- 0%	- 0%	- 0%	- 0%	- 0%	- 0%	
	Other	21 17.8%	- 0%	- 0%	- 0%	7 5.9%	67 56.8%	19 16.1%	- 0%	- 0%	4 3.4%	118 100%	
Alcohol - Related	DUI	354 56.8%	7 1.1%	2 0%	5 0.8%	29 4.7%	64 10.3%	69 11.1%	4 0.6%	- 0%	89 14.3%	623 100%	
	Liquor Laws	62 57.9%	- 0%	- 0%	2 1.9%	- 0%	14 13.1%	16 15%	- 0%	- 0%	13 12.1%	107 100%	
	Disorderly Conduct	84 54.2%	3 1.9%	- 0%	- 0%	5 3.2%	21 13.5%	27 17.4%	2 1.3%	1 0.6%	12 7.7%	155 100%	

Maui County Race/Ethnicity of Adults Arrested for Part II Offenses: 2003 - Continued

Type	Offense	Caucasian	African American	Indian	Chinese	Japanese	Filipino	Hawaiian	Korean	Samoan	Other	Total	
Other	Offenses Agst. Family/Children	5	-	-	1	1	2	3	-	-	2	14	
		35.7%	0%	0%	7.1%	7.1%	14.3%	21.4%	0%	0%	14.3%	100%	
	Prostitution	-	-	-	-	-	-	-	-	-	-	1	1
		0%	0%	0%	0%	0%	0%	0%	0%	0%	0%	100%	100%
	Suspicion	-	-	-	-	-	-	-	-	-	-	-	-
		0%	0%	0%	0%	0%	0%	0%	0%	0%	0%	0%	0%
	Vagrancy	-	-	-	-	-	-	-	-	-	-	-	-
		0%	0%	0%	0%	0%	0%	0%	0%	0%	0%	0%	0%
	Weapons	23	-	-	1	-	7	11	1	-	-	4	47
		48.9%	0%	0%	2.1%	0%	14.9%	23.4%	2.1%	0%	8.5%	100%	
All Other Offenses	1,892	59	3	29	173	682	1,055	27	8	482	4,410		
	42.9%	1.3%	0.1%	0.7%	3.9%	15.5%	23.9%	0.6%	0.2%	10.9%	100%		
TOTAL		2,972	100	8	45	285	1,103	1,531	46	15	723	6,828	
Column Percent		43.5%	1.5%	0.1%	0.7%	4.2%	16.2%	22.4%	0.7%	0.2%	10.6%	100%	

Source: State of Hawai'i Department of the Attorney General, Crime Prevention & Justice Assistance Division

Maui County Race/Ethnicity of Juveniles Arrested for Part II Offenses: 2003

Type	Offense	Caucasian	African American	Indian	Chinese	Japanese	Filipino	Hawaiian	Korean	Samoan	Other	Total
Violent	Negligent Manslaughter	-	-	-	-	-	-	-	-	-	-	-
		0%	0%	0%	0%	0%	0%	0%	0%	0%	0%	0%
	Other Assault	19	-	-	1	2	15	18	-	-	4	59
		32.2%	0%	0%	1.7%	3.4%	25.4%	30.5%	0%	0%	6.8%	100%
	Sex Offenses	1	-	-	-	-	2	-	-	-	-	3
33.3%		0%	0%	0%	0%	66.7%	0%	0%	0%	0%	100%	
Property - Related	Forgery	-	-	-	1	-	-	1	-	-	-	2
		0%	0%	0%	50%	0%	0%	50%	0%	0%	0%	100%
	Fraud	2	-	-	-	-	-	-	-	-	-	2
		100%	0%	0%	0%	0%	0%	0%	0%	0%	0%	100%
	Embezzlement	-	-	-	-	-	-	-	-	-	-	-
		0%	0%	0%	0%	0%	0%	0%	0%	0%	0%	0%
	Stolen Property	-	-	-	-	-	-	-	-	-	-	-
0%		0%	0%	0%	0%	0%	0%	0%	0%	0%	0%	
Vandalism	3	-	-	-	-	11	4	-	-	4	22	
	13.5%	0%	0%	0%	0%	50%	18.2%	0%	0%	18.2%	100%	
Drug Manufacturing / Sale	Opium or Cocaine	-	-	-	-	-	-	2	-	-	-	2
		0%	0%	0%	0%	0%	0%	100%	0%	0%	0%	100%
	Marijuana	6	1	-	-	-	-	4	-	-	-	11
		54.5%	9.1%	0%	0%	0%	0%	36.4%	0%	0%	0%	100%
	Synthetic Narcotic	-	-	-	-	-	-	-	-	-	-	-
		0%	0%	0%	0%	0%	0%	0%	0%	0%	0%	0%
	Nonnarcotic	1	-	-	-	-	-	1	-	-	-	2
50%		0%	0%	0%	0%	0%	50%	0%	0%	0%	100%	

Maui County Race/Ethnicity of Juveniles Arrested for Part II Offenses: 2003 - Continued

Type	Offense	Race/Ethnicity										Total
		Caucasian	African American	Indian	Chinese	Japanese	Filipino	Hawaiian	Korean	Samoan	Other	
Drug Possession	Opium or Cocaine	2	1	-	-	-	2	3	-	-	-	8
		25%	12.5%	0%	0%	0%	25%	37.5%	0%	0%	0%	100%
	Marijuana	36	2	-	-	1	7	30	-	-	6	82
		43.9%	2.4%	0.0%	0%	1.2%	8.5%	36.6%	0%	0%	7.3%	100%
	Synthetic Narcotic	-	-	-	-	-	-	-	-	-	-	-
	0%	0%	0%	0%	0%	0%	0%	0%	0%	0%	0%	
	Nonnarcotic	5	-	-	-	-	3	3	-	-	-	11
		45.5%	0%	0%	0%	0%	27.3%	27.3%	0%	0%	0%	100%
Gambling	Bookmaking	-	-	-	-	-	-	-	-	-	-	-
		0%	0%	0%	0%	0%	0%	0%	0%	0%	0%	0%
	Numbers & Lottery	-	-	-	-	-	-	-	-	-	-	-
		0%	0%	0%	0%	0%	0%	0%	0%	0%	0%	0%
	Other	-	-	-	-	-	1	-	-	-	-	1
0%		0%	0%	0%	0%	100%	0%	0%	0%	0%	100%	
Alcohol - Related	DUI	3	-	-	-	1	1	1	-	-	-	6
		50%	0%	0%	0%	16.7%	16.7%	16.7%	0%	0%	0%	100%
	Liquor Laws	21	1	-	-	2	1	5	-	-	3	33
		63.6%	3%	0%	0%	6.1%	3%	15.2%	0%	0%	9.1%	100%
	Disorderly Conduct	9	-	-	-	-	5	17	-	-	2	33
	27.3%	0%	0%	0%	0%	15.2%	51.5%	0%	0%	6.1%	100%	

Maui County Race/Ethnicity of Juveniles Arrested for Part II Offenses: 2003 - Continued

Type	Offense	Caucasian	African American	Indian	Chinese	Japanese	Filipino	Hawaiian	Korean	Samoan	Other	Total	
Other	Offenses Agst. Family/Children	1	-	-	-	-	-	-	-	-	-	1	
		100%	0%	0%	0%	0%	0%	0%	0%	0%	0%	100%	
	Prostitution	-	-	-	-	-	-	-	-	-	-	-	-
		0%	0%	0%	0%	0%	0%	0%	0%	0%	0%	0%	0%
	Suspicion	-	-	-	-	-	-	-	-	-	-	-	-
		0%	0%	0%	0%	0%	0%	0%	0%	0%	0%	0%	0%
	Vagrancy	-	-	-	-	-	-	-	-	-	-	-	-
		0%	0%	0%	0%	0%	0%	0%	0%	0%	0%	0%	0%
	Weapons	2	-	-	-	-	-	1	3	-	-	-	6
		33.3%	0%	0%	0%	0%	0%	16.7%	50%	0%	0%	0%	100%
All Other Offenses	43	2	-	-	7	20	67	1	-	8	148		
	29.1%	1.4%	0%	0%	4.7%	13.5%	45.3%	0.7%	0%	5.4%	100%		
Status	Curfew	15	1	-	-	3	36	21	-	-	2	78	
		19.2%	1.3%	0%	0%	3.8%	46.2%	26.9%	0.0%	0%	2.6%	100%	
	Runaway	47	2	-	2	10	32	45	-	-	18	156	
30.1%		1.3%	0%	1.3%	6.4%	20.5%	28.8%	0%	0%	11.5%	100%		
TOTAL		216	10	-	4	26	137	225	1	-	47	666	
Column Percent		32.4%	1.5%	0%	0.6%	3.9%	20.6%	33.8%	0.2%	0%	7.1%	100%	

Source: State of Hawai'i Department of the Attorney General, Crime Prevention & Justice Assistance Division

Hawai'i County Race/Ethnicity of Adults Arrested for Index Offenses: 2003

Offense / Row %	Caucasian	African American	Indian	Chinese	Japanese	Filipino	Hawaiian	Korean	Samoan	Other	Total
Murder	3	-	-	-	-	-	-	-	-	-	3
	100%	0%	0%	0%	0%	0%	0%	0%	0%	0%	100%
Forcible Rape	11	-	-	-	1	-	2	-	-	-	14
	78.6%	0%	0%	0%	7.1%	0%	14.3%	0%	0%	0%	100%
Robbery	13	1	-	-	-	3	11	-	-	1	29
	44.8%	3.4	0%	0%	0%	10.3%	37.9%	0%	0%	3.4%	100%
Aggravated Assault	25	1	1	1	4	4	25	-	2	6	69
	36.2%	1.4%	1.4%	1.4%	5.8%	5.8%	36.2	0%	2.9%	8.7%	100%
Burglary	42	4	-	-	7	5	31	1	2	7	99
	42.4%	4%	0%	0%	7.1%	5.1%	31.3%	1%	2%	7.1%	100%
Larceny - Theft	220	14	3	1	23	44	131	4	5	29	474
	46.4%	3%	0.6%	0.2%	4.9%	9.3%	27.6%	0.8%	1.1%	6.1%	100%
Motor Vehicle Theft	34	1	-	-	-	9	40	-	-	5	89
	38.2%	1.1%	0%	0%	0%	10.1%	44.9%	0%	0%	5.6%	100%
Arson	1	-	-	-	-	-	-	-	-	-	1
	100%	0%	0%	0%	0%	0%	0%	0%	0%	0%	100%
TOTAL	349	21	4	2	35	65	240	5	9	48	778
Column Percent	44.9%	2.7%	0.5%	0.3%	4.5%	8.4%	30.8%	0.6%	1.2%	6.2%	100%

Source: State of Hawai'i Attorney General, Crime Prevention & Justice Assistance Division

Hawai'i County Race/Ethnicity of Juveniles Arrested for Index Offenses: 2003

Offense / Row %	Caucasian	African American	Indian	Chinese	Japanese	Filipino	Hawaiian	Korean	Samoaan	Other	Total
	-	-	-	-	-	-	-	-	-	-	-
Murder	0%	0%	0%	0%	0%	0%	0%	0%	0%	0%	0%
	-	-	-	-	-	-	2	-	-	-	2
Forcible Rape	0%	0%	0%	0%	0%	0%	100%	0%	0%	0%	100%
	3	-	-	-	-	-	7	-	-	1	11
Robbery	27.3%	0%	0%	0%	0%	0%	63.6%	0%	0%	9.1%	100%
	1	-	-	-	1	-	3	-	-	-	5
Aggravated Assault	20%	0%	0%	0%	20%	0%	60%	0%	0%	0%	100%
	17	1	-	1	2	3	24	-	-	9	57
Burglary	29.8%	1.8%	0%	1.8%	3.5%	5.3%	42.1%	0%	0%	15.8%	100%
	73	3	-	1	6	14	62	3	2	26	190
Larceny - Theft	38.4%	1.6%	0%	0.5%	3.2%	7.4%	32.6%	1.6%	1.1%	13.7%	100%
	2	-	-	-	3	1	11	-	-	1	18
Motor Vehicle Theft	11.1%	0%	0%	0%	16.7%	5.6%	61.1%	0%	0%	5.6%	100%
	-	-	-	-	-	-	-	-	-	-	-
Arson	0%	0%	0%	0%	0%	0%	0%	0%	0%	0%	0%
TOTAL	96	4	-	2	12	18	109	3	2	37	283
Column Percent	33.9%	1.4%	0%	0.7%	4.2%	6.4%	38.5%	1.1%	0.7%	13.1%	100%

Source: State of Hawai'i Attorney General, Crime Prevention & Justice Assistance Division

Hawai'i County Race/Ethnicity of Adults Arrested for Part II Offenses: 2003

Type	Offense	Caucasian	African American	Indian	Chinese	Japanese	Filipino	Hawaiian	Korean	Samoaan	Other	Total
Violent	Negligent Manslaughter	4	-	-	-	1	-	2	-	-	-	7
		57%	0%	0%	0%	14%	0%	29%	0%	0%	0%	100%
	Other Assault	261	12	4	3	26	73	239	-	5	53	676
		38.6%	1.8%	0.6%	0.4%	3.8%	10.8%	35.4%	0.0%	0.7%	7.8%	100%
	Sex Offenses	12	2	-	-	1	2	4	-	-	2	23
		52.2%	8.7%	0%	0%	4.3%	8.7%	17.4%	0%	0%	8.7%	100%
Property - Related	Forgery	14	2	-	-	1	3	10	-	-	-	30
		46.7%	6.7%	0%	0%	3.3%	10%	33.3%	0%	0%	0%	100%
	Fraud	31	1	1	-	1	4	15	-	-	4	57
		54.4%	1.8%	1.8%	0%	1.8%	7%	26.3%	0%	0%	7%	100%
	Embezzlement	-	-	-	-	-	-	-	-	-	-	-
	Stolen Property	4	-	-	-	-	1	2	-	-	-	7
		57.1%	0%	0%	0%	0%	14.3%	28.6%	0%	0%	0%	100%
Vandalism	22	-	1	-	3	4	24	-	3	8	65	
	33.8%	0%	1.5%	0%	4.6%	6.2%	36.9%	0%	4.6%	12.3%	100%	
Drug Manufacturing / Sale	Opium or Cocaine	20	-	1	-	-	2	8	-	-	-	31
		64.5%	0%	3%	0%	0%	6.5%	25.8%	0%	0%	0%	100%
	Marijuana	46	1	2	2	3	7	25	-	-	4	90
		51.1%	1.1%	2.2%	2.2%	3.3%	7.8%	27.8%	0%	0%	4.4%	100%
	Synthetic Narcotic	1	-	-	-	-	-	-	-	-	-	1
		100%	0%	0%	0%	0%	0%	0%	0%	0%	0%	100%
Nonnarcotic	54	4	1	3	3	27	65	-	-	13	170	
	31.8%	2.4%	0.6%	1.8%	1.8%	15.9%	38.2%	0%	0%	7.6%	100%	

Hawai'i County Race/Ethnicity of Adults Arrested for Part II Offenses: 2003 - Continued

Type	Offense	Caucasian	African American	Indian	Chinese	Japanese	Filipino	Hawaiian	Korean	Samoaan	Other	Total	
Drug Possession	Opium or Cocaine	9	-	-	1	1	1	3	-	-	-	15	
		60%	0%	0%	6.7%	6.7%	6.7%	20%	0%	0%	0%	100%	
	Marijuana	61	1	-	-	5	1	32	-	1	3	104	
		58.7%	1%	0%	0%	4.8%	1%	30.8%	0%	1%	2.9%	100%	
	Synthetic Narcotic	-	-	-	-	-	-	1	-	-	-	1	
		0%	0%	0%	0%	0%	0%	100%	0%	0%	0%	100%	
Nonnarcotic		61	2	-	2	7	7	50	-	-	6	135	
		45.2%	1.5%	0%	1.5%	5.2%	5.2%	37%	0%	0%	4.4%	100%	
Gambling		-	-	-	-	-	-	-	-	-	-	-	
	Bookmaking	0%	0%	0%	0%	0%	0%	0%	0%	0%	0%	0%	
	Numbers & Lottery	-	-	-	-	-	-	-	-	-	-	-	-
		0%	0%	0%	0%	0%	0%	0%	0%	0%	0%	0%	0%
	Other	1	-	-	1	1	1	-	-	-	-	4	
	25%	0%	0%	25%	25%	25%	0%	0%	0%	0%	100%		
Alcohol - Related		543	12	5	9	61	76	210	4	6	91	1,017	
	DUI	53.4%	1.2%	0.5%	0.9%	6%	7.5%	20.6%	0.4%	0.6%	8.9%	100%	
		88	1	2	-	15	22	46	1	3	20	198	
	Liquor Laws	44.4%	0.5%	1%	0%	7.6%	11.1%	23.2%	0.5%	1.5%	10.1%	100%	
Disorderly Conduct		56	3	1	2	2	4	29	1	1	7	106	
		52.8%	2.8%	0.9%	1.9%	1.9%	3.8%	27.4%	0.9%	0.9%	6.6%	100%	

Hawai'i County Race/Ethnicity of Adults Arrested for Part II Offenses: 2003 - Continued

Type	Offense	Caucasian	African American	Indian	Chinese	Japanese	Filipino	Hawaiian	Korean	Samoaan	Other	Total	
Other	Offenses Agst. Family/Children	-	-	-	-	-	-	1	-	-	-	1	
		0%	0%	0%	0%	0%	0%	100%	0%	0%	0%	100%	
	Prostitution	-	-	-	-	-	-	-	-	-	-	-	-
		0%	0%	0%	0%	0%	0%	0%	0%	0%	0%	0%	0%
	Suspicion	-	-	-	-	-	-	-	-	-	-	-	-
		0%	0%	0%	0%	0%	0%	0%	0%	0%	0%	0%	0%
	Vagrancy	-	-	-	-	-	-	-	-	-	-	-	-
		0%	0%	0%	0%	0%	0%	0%	0%	0%	0%	0%	0%
Weapons	8	-	-	-	-	2	7	6	-	-	1	24	
	33.3%	0%	0%	0%	0%	8.3%	29.2%	25%	0%	0%	4.2%	100%	
All Other Offenses	1,975	69	23	20	166	428	1,561	8	35	327	4,612		
	42.8%	1.5%	0.5%	0.4%	3.6%	9.3%	33.8%	0.2%	0.8%	7.1%	100%		
TOTAL		3,271	110	41	43	299	670	2,333	14	54	539	7,374	
Column Percent		44.4%	1.5%	0.6%	0.6%	4.1%	9.1%	31.6%	0.2%	0.7%	7.3%	100%	

Source: State of Hawai'i Department of the Attorney General, Crime Prevention & Justice Assistance Division

Hawai'i County Race/Ethnicity of Juveniles Arrested for Part II Offenses: 2003

Type	Offense	Caucasian	African American	Indian	Chinese	Japanese	Filipino	Hawaiian	Korean	Samoan	Other	Total	
Violent	Negligent Manslaughter	-	-	-	-	1	-	-	-	-	-	1	
		0%	0%	0%	0%	100%	0%	0%	0%	0%	0%	100%	
	Other Assault	20	-	-	1	3	7	28	-	2	20	81	
		24.7%	0%	0%	1.2%	3.7%	8.6%	34.6%	0%	2.5%	24.7%	100%	
	Sex Offenses	3	-	-	-	-	-	-	6	-	-	1	10
		30%	0%	0%	0%	0%	0%	0%	60%	0%	0%	10%	100%
Property - Related	Forgery	1	-	-	-	-	-	-	-	-	-	1	
		100%	0%	0%	0%	0%	0%	0%	0%	0%	0%	100%	
	Fraud	4	-	-	-	-	-	-	2	-	-	1	7
		57.1%	0%	0%	0%	0%	0%	28.6%	0%	0%	14.3%	100%	
	Embezzlement	-	-	-	-	-	-	-	-	-	-	-	-
		0%	0%	0%	0%	0%	0%	0%	0%	0%	0%	0%	
	Stolen Property	-	-	-	-	-	-	-	-	-	-	-	-
0%		0%	0%	0%	0%	0%	0%	0%	0%	0%	0%		
Vandalism	18	-	-	-	1	5	9	-	-	8	41		
	43.9%	0%	0%	0%	2.4%	12.2%	22.0%	0%	0%	19.5%	100%		
Drug Manufacturing / Sale	Opium or Cocaine	-	-	-	-	-	-	-	-	-	-	-	
		0%	0%	0%	0%	0%	0%	0%	0%	0%	0%		
	Marijuana	2	-	-	-	1	1	5	-	-	-	9	
		22.2%	0%	0%	0%	11.1%	11.1%	55.6%	0%	0%	0%	100%	
	Synthetic Narcotic	-	-	-	-	-	-	-	-	-	-	-	
		0%	0%	0%	0%	0%	0%	0%	0%	0%	0%	0%	
	Nonnarcotic	3	-	-	-	-	1	2	-	-	-	6	
50%		0%	0%	0%	0%	16.7%	33.3%	0%	0%	0%	100%		

Hawai'i County Race/Ethnicity of Juveniles Arrested for Part II Offenses: 2003 - Continued

Type	Offense	Caucasian	African American	Indian	Chinese	Japanese	Filipino	Hawaiian	Korean	Samoaan	Other	Total
Drug Possession	Opium or Cocaine	-	-	-	-	-	-	-	-	-	-	-
		0%	0%	0%	0%	0%	0%	0%	0%	0.0%	0%	0%
	Marijuana	45	3	-	-	5	16	40	-	1	9	119
		37.8%	2.5%	0%	0%	4.2%	13.4%	33.6%	0%	0.8%	7.6%	100%
	Synthetic Narcotic	-	-	-	-	-	-	-	-	-	-	-
	0%	0%	0%	0%	0%	0%	0%	0%	0%	0%	0%	
	1	-	-	-	-	-	-	3	-	-	-	4
	Nonnarcotic	25%	0%	0%	0%	0%	0%	75%	0%	0%	0%	100%
Gambling		-	-	-	-	-	-	-	-	-	-	-
	Bookmaking	0%	0%	0%	0%	0%	0%	0%	0%	0%	0%	0%
		-	-	-	-	-	-	-	-	-	-	-
	Numbers & Lottery	0%	0%	0%	0%	0%	0%	0%	0%	0%	0%	0%
		-	-	-	-	-	-	-	-	-	-	-
	Other	0%	0.0%	0%	0%	0.0%	0.0%	0.0%	0%	0%	0%	0%
Alcohol - Related		16	1	-	-	2	1	12	-	-	2	34
	DUI	47.1%	2.9%	0%	0%	5.9%	2.9%	35.3%	0%	0%	5.9%	100%
		27	-	-	1	9	5	16	-	1	5	64
	Liquor Laws	42.2%	0%	0%	1.6%	14.1%	7.8%	25%	0%	1.6%	7.8%	100%
	10	-	-	-	1	2	6	-	-	-	19	
	Disorderly Conduct	52.6%	0%	0%	0%	5.3%	10.5%	31.6%	0%	0%	0%	100%

Hawai'i County Race/Ethnicity of Juveniles Arrested for Part II Offenses: 2003 - Continued

Type	Offense	Caucasian	African American	Indian	Chinese	Japanese	Filipino	Hawaiian	Korean	Samoaan	Other	Total	
Other	Offenses Agst. Family/Children	-	-	-	-	-	-	-	-	-	-	-	
		0%	0%	0%	0%	0%	0%	0%	0%	0%	0%	0%	
	Prostitution	-	-	-	-	-	-	-	-	-	-	-	-
		0%	0%	0%	0%	0%	0%	0%	0%	0%	0%	0%	0%
	Suspicion	-	-	-	-	-	-	-	-	-	-	-	-
		0%	0%	0%	0%	0%	0%	0%	0%	0%	0%	0%	0%
	Vagrancy	-	-	-	-	-	-	-	-	-	-	-	-
		0%	0%	0%	0%	0%	0%	0%	0%	0%	0%	0%	0%
Weapons	-	-	-	-	-	-	-	1	-	-	2	3	
	0%	0%	0%	0%	0%	0%	0%	33.3%	0%	0%	66.7%	100%	
All Other Offenses	73	3	-	-	11	15	75	-	-	31	208		
	35.1%	1.4%	0%	0%	5.3%	7.2%	36.1%	0%	0%	14.9%	100%		
Status		26	-	-	-	1	5	16	-	-	5	53	
	Curfew	49.1%	0%	0%	0%	1.9%	9.4%	30.2%	0%	0%	9.4%	100%	
		234	21	-	-	20	71	217	1	4	61	629	
	Runaway	37.2%	3.3%	0%	0%	3.2%	11.3%	34.5%	0.2%	0.6%	9.7%	100%	
TOTAL		483	28	-	2	55	129	438	1	8	145	1,289	
Column Percent		37.5%	2.2%	0%	0.2%	4.3%	10%	34%	0.1%	0.6%	11.2%	100%	

Source: State of Hawai'i Department of the Attorney General, Crime Prevention & Justice Assistance Division

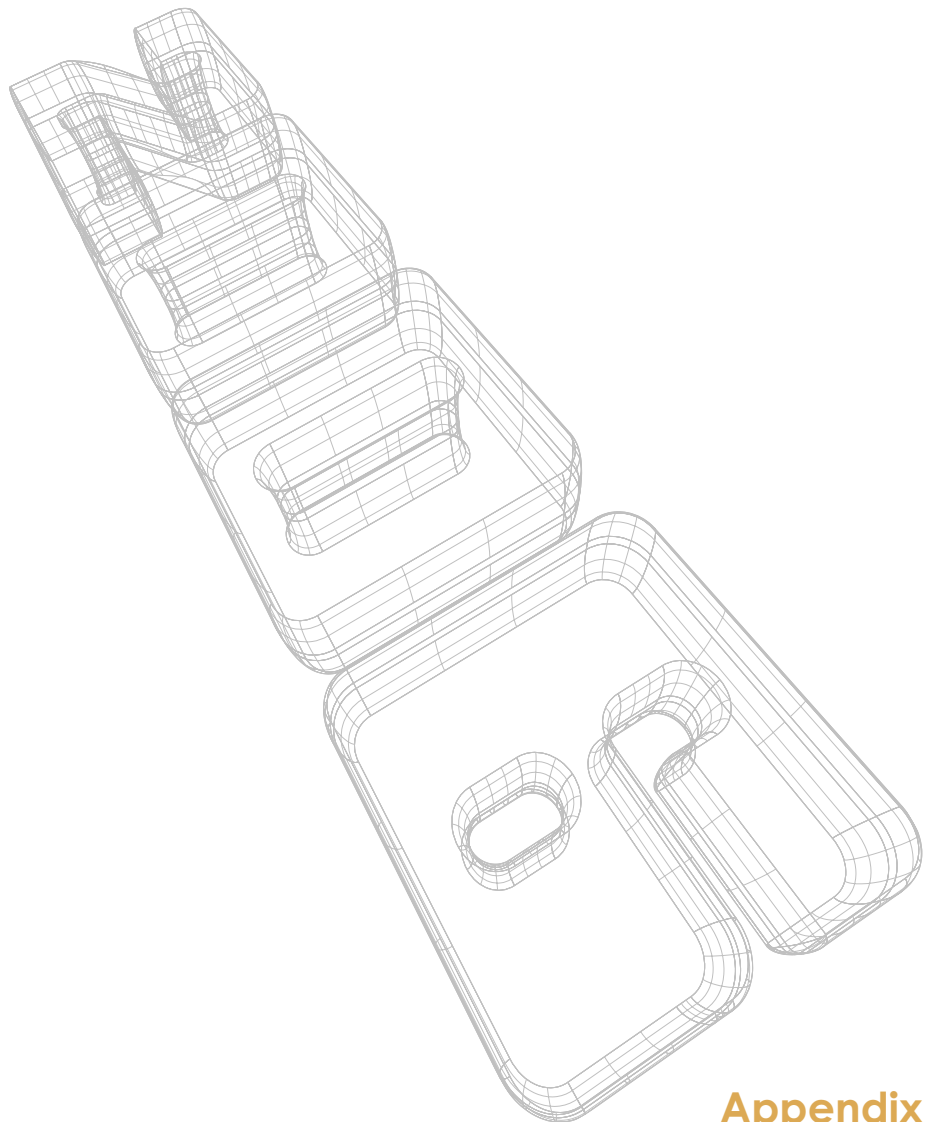

APPENDIX

Who is a “Hawaiian”?

The principal issue is that there is no single definition of “Hawaiian.” Agencies, organizations, and institutions address the question of race with a wide assortment of methodologies and procedures, which has resulted in a wide difference in population estimates for Native Hawaiians. While currently there is no “full proof” way to account for ALL Native Hawaiians and native Hawaiians in Hawai‘i and throughout the continent, major changes are being made to how data on race is being gathered to more accurately portray the total number of Hawaiians.

“Native Hawaiian” versus “native Hawaiian”

The Office of Hawaiian Affairs and other agencies and organizations frequently use the terminologies: “Native Hawaiian” and “native Hawaiian.”

“Native Hawaiian:” Native Hawaiian with an upper case “N” refers to all persons of Hawaiian ancestry regardless of blood quantum.

“native Hawaiian:” Native Hawaiian with a lower case “n” refers to those with 50% and more Hawaiian blood.

Different designations are utilized due to the different tiers of entitlements and benefits accorded by one’s blood quantum.

Definitions of “Hawaiian”

Hawai‘i State, Department of Education (DOE)

For students enrolled in the Department of Education school system, race is based on the student’s enrollment application which is completed by the parent(s) of each student. Race is indicated through a single-category self-identification check list. The check list includes the categories of “Hawaiian” and “Part-Hawaiian.”

For employees in the Department of Education, race is indicated through a single-category self-identification check list and recorded in their employment records. “Hawaiian” is listed as a single-category. There is no “Part-Hawaiian” category.

Hawai'i State, Department of Hawaiian Home Lands (DHHL)

Hawaiian Homes Commission Act, 1920.
Title 2 – Hawaiian Homes Commission.
Sec. 201. (a) (7).

The term “native Hawaiian” means any descendant of not less than one-half of the blood of the races inhabiting the Hawaiian Islands previous to 1778.

Beneficiaries of the Department of Hawaiian Home Lands are persons of at least 50 percent Hawaiian blood. The department determines and verifies native Hawaiian blood qualification through birth certificates and genealogical research.

Hawai'i State, Department of Health (DOH) Behavioral Risk Factor Surveillance Survey (BRFSS)

The Behavioral Risk Factor Surveillance Survey is a random-digit dialing telephone interview survey. The data on the race of a respondent is determined from answers to the questionnaire item that asks, “What is your race?” The survey respondent self-identifies his/her race from a list of ten single racial categories read to them: Caucasian, Hawaiian/Part-Hawaiian, Chinese, Filipino, Japanese, Korean, Samoan/Tongan, Black, Aleutian/Alaskan, and Other—Specify. Responses not read to the respondent, but are recorded if necessary are: Don't Know/Not Sure and Refused. “Hawaiian/Part-Hawaiian” is listed as a single-category. The data collected is based on a random sample and is subject to sampling variability. The sample population is drawn from residents over 18 years of age and is weighted to be representative of the age, sex and race distribution of the state.

Hawai'i State, Department of Health (DOH) Hawai'i Health Survey (HHS)

The Respondent can list up to four ethnicities for both (and for each household member) their mother and their father. The choices were White/Caucasian, Hawaiian, Chinese, Filipino, Japanese, Korean, Samoan/Tongan, Black/African American, Native American/Aleut/Eskimo/Inuit, Vietnamese, Asian Indian, Portuguese, and Guamanian/Chamorro. In addition, they can specify another ethnicity if it is not listed, or they can reply they do not know, or refuse to answer.

The Office of Health Status Monitoring codes these eight possible choices for each individual to one ethnicity in order to comply with prior Census rules coding race/ethnicity. Specifically, if Hawaiian is listed for the Mother or Father the person is coded to Hawaiian. Otherwise, the person is coded to the first ethnicity listed (other than Caucasian or unknown) for the Father. If the Father's responses are Caucasian and/or unknown, the person's ethnicity is coded to the first ethnicity listed (other than Caucasian or unknown) for the Mother. If there are no other responses other than Caucasian or unknown, the person is coded to Caucasian. Otherwise, the person is coded to do not know, refused, or missing.

Hawai'i State, Department of Health (DOH) Office of Health Status Monitoring (OHSM)

The vital statistics data presented by the Office of Health Status Monitoring are derived from the information registered on the Birth, Death, and Marriage Certificates. The birth certificates report the race of the mother and father, if known/reported. Race is designated through self-identification, and multiple racial identifiers can be listed. The Hawai'i State Department of Health determines a child's race from the parents' ethnic group following coding procedures:

1. If both parents are of the same race, the child's race is the parents' race.
2. If either parent is of unknown race, the child's race is that of the parent with the known race.
3. If either parent is Hawaiian or Part-Hawaiian, the child's race is Part-Hawaiian.
4. If either parent is Black, child's race is Black (except Hawaiian and Part-Hawaiian).
5. If parents' races are White, but not the same (Caucasian, Puerto Rican, Portuguese, Cuban, or Mexican), the child's race is that of the father's race.
6. If one parent is White and the other parent is non-White, the child's race is that of the non-White parent.
7. If both parents are non-White, but not the same race, the child's race is that of the father.

Death certificates record information on the race of the deceased. Race is reported by family, next of kin, or health care professionals. Multiple racial identifiers can be listed on death certificates.

Marriage certificates record information on the race of both the bride and the groom. The race of each is designated through self-identification, and multiple racial identifiers can be listed.

In the reporting of vital statistics data, Caucasian excludes Portuguese. There is a separate category for people of Portuguese ancestry, except for marriages, where they are combined with Caucasian.

In reported vital statistics data, the category of "Hawaiian" also includes "Part-Hawaiian."

It should be noted that only one ethnicity is coded from the actual certificates. If more than one ethnicity is listed on the certificate, the following rules apply:

1. If Hawaiian is one of the multiple ethnicities listed, Part-Hawaiian is coded.
2. If a non-Caucasian ethnicity is listed with a Caucasian ethnicity, the non-Caucasian ethnicity is coded.
3. If there is more than one non-Caucasian ethnicity listed, the first one is coded.
4. If there is more than one Caucasian ethnicity listed, the first is coded.

Hawai'i State, Department of Human Services (DHS)

For those receiving assistance (Aid to Families with Dependent Children (AFDC), Aid to Aged, Blind and Disabled (ABD), General Assistance, Food Stamps, Medical) from the Department of Human Services, race is designated through a self-identification single-category check list on an assistance application form. "Hawaiian" is listed as a single-category. There is no "Part-Hawaiian" category.

Hawai'i State, Department of Public Safety (PSD)

The race of those admitted to the facilities under the control of the Department of Public Safety is indicated through self-identification as recorded on an intake assessment form. For those who report a multiple race backgrounds, up to three racial identifiers are recorded for that individual.

In the reporting of their data:

Classification of persons into the ten following groups based on their self-reported ethnicity: Black, Caucasian, Chinese, Filipino, Hawaiian or Part-Hawaiian, Japanese, Korean, Other, Samoan, and Not reported.

Caucasians include persons who reported their ethnicity as Portuguese.

"Other and Mixed" represents persons who reported two or more ethnicities (other than Hawaiian or Part-Hawaiian) or identified themselves with a single ethnic group, not corresponding to any of the distinct groups.

Hawai'i State, Department of the Attorney General (ATG) Crime Prevention Division

The crime data reported by the Crime Prevention Division is based upon the Uniform Crime Reporting (UCR) Program's monthly offense and arrest reports. The reports are voluntarily submitted by the four county police departments. Information on race is recorded on the arrest reports. The arrest reports are completed by the arresting officers. The arresting officers receive the race information from the arrestee through visual observation or make a determination based on the arrestee's last name. There is no standardization for racial/ethnic identification among the police departments or within each police department.

Hawai'i State, Office of Elections

Hawai'i Revised Statutes
[Chapter 11] Elections, Generally
[§ 10-2] Definitions.

"Hawaiian," any descendant of the aboriginal peoples inhabiting the Hawaiian Islands which exercised sovereignty and subsisted in the Hawaiian Islands in 1778, and which peoples there after have continued to reside in Hawai'i;

“native Hawaiian” means any descendant of not less than one-half part of the races inhabiting the Hawaiian Islands previous to 1778, as defined by the Hawaiian Homes Commission Act, 1920, as amended; provided that the term identically refers to the descendants of such blood quantum of such aboriginal peoples which exercised sovereignty and subsisted in the Hawaiian Islands in 1778 and which peoples thereafter continued to reside in Hawai‘i...

Hawai‘i State, University of Hawai‘i (UOH)

For students enrolled in the University of Hawai‘i system, race is reported on the student’s admission application. Race is designated through a single-category self-identification check list. “Hawaiian/Part-Hawaiian” is listed as a single-category.

Beginning in Fall 2005, students are asked to answer yes or no to an optional question: “Were any of your ancestors Hawaiian?” Data on the answers to this question will be input to the UOH database. However, only applicants and incoming students will be asked this question; data will not be available for students who applied or enrolled prior to Fall 2005.

Faculty and staff in the University of Hawai‘i system report race at the time of their hire via Form 27. Race is designated through a single-category self-identification check list. “Hawaiian” and “Part-Hawaiian” are listed as separate categories.

United States, Bureau of the Census

Prior to Census 2000, Hawaiian was defined by the data on race derived from answers to questionnaire item four, which asks the race of all persons in the household.

The concept of race as used by the Census Bureau reflects self-identification; it does not denote any clear-cut scientific definition of biological stock. The data for race represent self-identification by people according to the race which they most closely identify. Furthermore, it is recognized that the categories of the race item include both racial and national origin or socio-cultural groups.

Hawaiian includes persons who indicated their race as “Hawaiian” as well as persons who identified themselves as Part-Hawaiian or Native-Hawaiian.

Note: Portuguese are classified as “Portuguese” and not as “Caucasian.”

The U.S. Bureau of the Census collects data on ancestry. The data on ancestry derives from answers to questionnaire item 13, which asks of a sample of persons. The data are estimates of the actual figures that would have been obtained from a complete count. The data collected is based on a random sample and is subject to sampling variability.

The question was based on self-identification; the data on ancestry represent self-classification by people according to the ancestry group(s) with which they most closely

identify. Ancestry refers to a person's ethnic origin or descent, "roots," or heritage or the place of birth of the person or the person's parents or ancestors before their arrival in the United States.

The U.S. Bureau of the Census uses information on place of birth and citizenship to classify the population into two major categories: native and foreign born.

Native includes persons born in the United States, Puerto Rico, or an outlying area of the United States. The small number of persons who were born in a foreign country but have at least one American parent also are included in this category.

The native population is classified in the following groups: persons born in the State in which they resided at the time of the census; persons born in a different State, by region; persons born in Puerto Rico or an outlying area of the U.S.; and persons born abroad with at least one American parent.

In this circumstance, discretion should be exercised in using the term, "Native Hawaiian." The U.S. Bureau of the Census definition of "Native Hawaiian" is vastly different from other definitions of Native Hawaiian.

The most profound change to the question on race for Census 2000 is that respondents are allowed to identify one or more races to indicate their racial identity. There are 15 check box response categories and 3 write-in areas on the Census 2000 questionnaire, compared with 16 check box response categories and 2 write-in areas in 1990. The Asian and Pacific Islander category has been split into two categories Asian, and Native Hawaiian and Other Pacific Islander. There are six specified Asian and three detailed Pacific Islander categories shown on the Census 2000 questionnaires, as well as Other Asian and Other Pacific Islander which have write-in areas for respondents to provide other race responses. All of the responses collected in Census 2000 can be collapsed into the minimum race categories identified in the 1997 revisions to the standards on race and ethnicity issued by the Office of Management and Budget, plus the category Some Other Race.

Other changes include terminology and formatting changes, such as spelling out "American" instead of "Amer." for the American Indian or Alaska Native category; and adding "Native" to the Hawaiian response category. In the layout of the Census 2000 questionnaire, the Asian response categories were alphabetized and grouped together, as were the Pacific Islander categories after the Native Hawaiian category. American Indians and Alaska Natives can report one or more tribes. In addition, the question on Hispanic origin is sequenced immediately before the question on race. For purposes of using Census 2000 data, "Native Hawaiian, single race" reflects the number of people who selected no other race. "Native Hawaiian, one or more races" is the total number of people selecting Native Hawaiian and any other race. Native Hawaiian and Hawaiian, therefore, will be used synonymously, to include all Hawaiians.

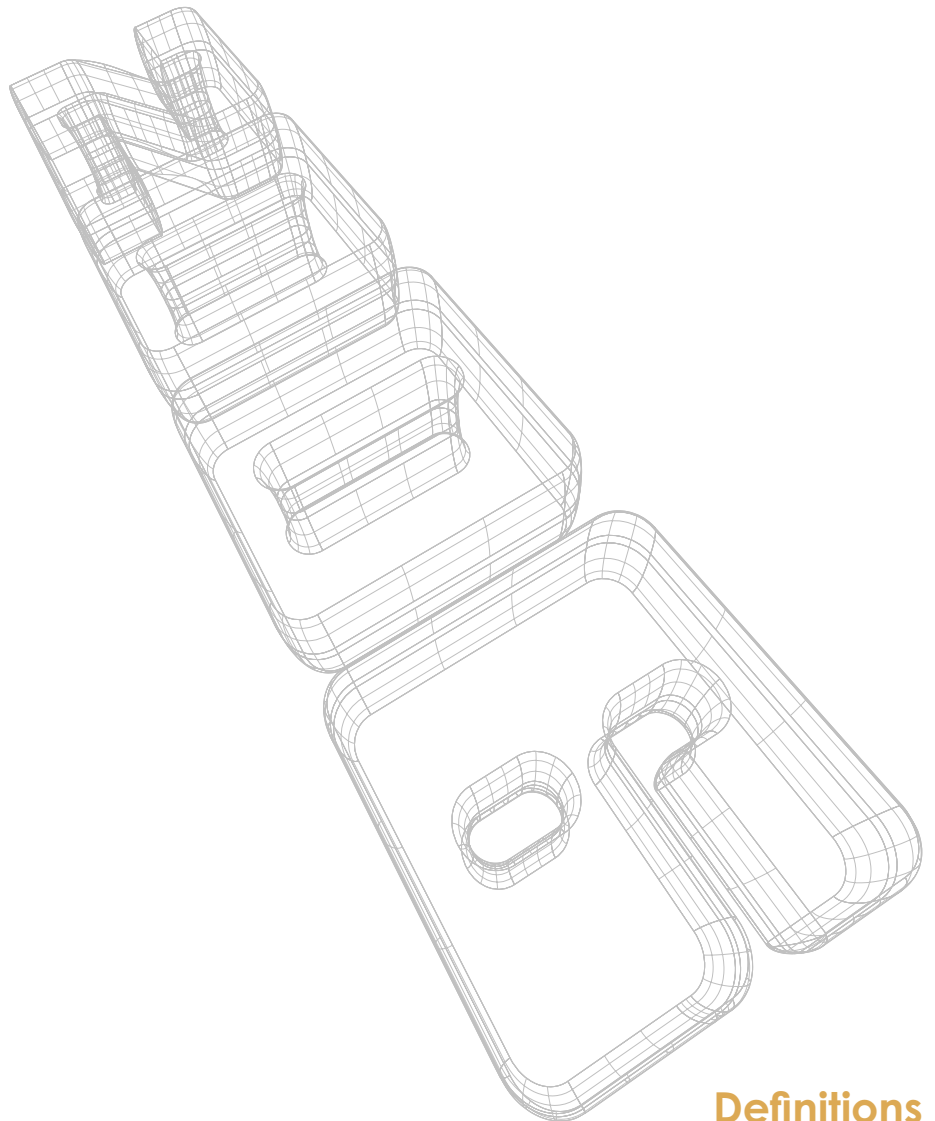

Definitions

Abortion rate:

Abortions x 1000 / Population of women 15 to 44 years of age (Hawai'i, Department of Health)

Abortion ratio I:

Abortions x 1000 / live births (Hawai'i, Department of Health)

Abortion ratio II:

Abortions x 1000 / (Live births + Fetal deaths + Abortions) (Hawai'i, Department of Health)

Age:

Age is reported as age at last birthday, that is, age in completed years.

Age-specific birth rate:

The number of live births in a given year per 1,000 women of a specified age. Generally in terms of five-year age groups. (Hawai'i, Department of Health)

Age-specific death rate:

The number of deaths occurring in a given year per 1,000 persons of a specified age and sex. Generally in terms of five-year age groups and given separately for male and female. (Hawai'i, Department of Health)

Aggravated assault:

An unlawful attack by one person upon another for the purpose of inflicting severe or aggravated bodily injury; attempted murder. This type of assault usually is accompanied by the use of a weapon or by means likely to produce death or great bodily harm. It is not necessary that injury result from an aggravated assault when a gun, knife, or other weapon is used which could and probably would result in serious personal injury if the crime were successfully completed. Attacks by personal weapons such as hands, fists, feet, etc., which result in serious or aggravated injury. (Hawai'i, Department of the Attorney General)

Arson:

Any willful or malicious burning or attempt to burn, with or without intent to defraud, a dwelling house, public building, motor vehicle or aircraft, personal property of another, etc. (Hawai'i, Department of the Attorney General)

Assault:

An unlawful attack by one person upon another. Includes Aggravated Assault (Part I Offense) and Other Assaults (Part II Offense). (Hawai'i, Department of the Attorney General)

Assault, other:

Assaults and attempted assaults where no weapon was used or which did not result in serious or aggravated injury to the victim. Examples include simple assault, assault and battery, resisting or obstructing an officer, intimidation, coercion, and hazing. (Hawai'i, Department of the Attorney General)

Assigned count:

The number of inmates who were physically in custody in one of Hawai'i's correctional facilities; and who were under the jurisdiction of the Hawai'i Department of Public Safety and located in another state's facility; on furlough; on escape status; or in a medical facility. (Hawai'i, Department of Public Safety)

Birth cohort:

A birth cohort consists of all persons born within a given period of time, such as a calendar year.

(U.S. Department of Health and Human Services)

Birth defect:

Any structural, functional, or biochemical abnormality in development that originates before birth and is detectable at birth or shortly thereafter. (Hawai'i, Department of Health)

Birthweight:

The first weight of the newborn obtained after birth. Low birthweight is defined as less than 2,500 grams or 5 pounds 8 ounces. Very low birthweight is defined as less than 1,500 grams or 3 pounds 4 ounces. Before 1979, low birth weight was defined as 2,500 grams or less and very low birthweight as 1,500 grams or less. (U.S. Department of Health and Human Services)

Burglary:

The unlawful entry of a structure to commit a felony or theft. Includes forcible entry, unlawful entry where no force is used, and attempted forcible entry where no entry occurs. (Hawai'i, Department of the Attorney General)

Child abuse and neglect:

The acts or omissions of any person who, or illegal entity which, is in any manner or degree related to the child, is residing with the child, or is otherwise responsible for the child's care, that have resulted in the physical or psychological health or welfare of the child, who is under the age of 18, to be harmed, or to be subject to any reasonably foreseeable substantial risk of being harmed. (Chapter 350: Child Abuse, §350-1)

Civilian labor force:

Consists of persons classified as employed or unemployed in accordance with the employed/unemployed criteria, excluding those in the armed forces and 16 years of age or under. (U.S. Census Bureau)

Child abuse and neglect:

The acts or omissions of any person who, or illegal entity which, is in any manner or degree related to the child, is residing with the child, or is otherwise responsible for the child's care, that have resulted in the physical or psychological health or welfare of the child, who is under the age of eighteen, to be harmed, or to be subject to any reasonably foreseeable substantial risk of being harmed. (Chapter 350: Child Abuse, §350-1)

Civilian labor force:

Consists of persons classified as employed or unemployed in accordance with the employed/unemployed criteria, excluding those in the armed forces and 16 years of age or under. (U.S. Census Bureau)

Clearance:

An offense is "cleared" by either arrest or exceptional means. An offense is cleared by arrest when at least one person is arrested; charged with the commission of the offense; and turned over to the court for prosecution. An offense is cleared by exceptional means when the identity of the offender is known; there is enough evidence to support an arrest, charge, and turning over to the court for prosecution; the exact location of the offender is known; and, for reasons outside the control of law enforcement, the offender cannot be arrested, charged, and prosecuted. Examples of cleared offenses by exceptional means include suicide of the offender, double murder, deathbed confession, and denied extradition. It should be noted that the number of offenses and not the number of persons arrested is used to count clearances. Several offenses may be cleared by the arrest of one person; or the arrest of several people may clear only one offense. (Hawai'i, Department of the Attorney General)

Crime Index:

The eight Part I Offenses reported in the Uniform Crime Reporting Program to represent the status of crime in the United States: murder and non-negligent manslaughter (the latter term is not used in Hawai'i), forcible rape, robbery, aggravated assault, burglary, larceny-theft, motor vehicle theft, and arson. (Hawai'i, Department of the Attorney General)

Crime Rate:

The number of crimes per 100,000 population (usually the resident populations) is obtained using the following equation: $\text{crime rate} = (\text{number of crimes} / \text{resident population}) \times 100,000$ (Hawai'i, Department of the Attorney General)

Criminal homicide:

The willful (non-negligent) killing of one human being by another or the killing of another person through gross negligence. Includes Murder and Non-negligent Manslaughter (the latter term is not used in Hawai'i), and Manslaughter by Negligence. (Hawai'i, Department of the Attorney General)

Crude birth weight: $\text{Live births} \times 1000 / \text{Total population}$ (Hawai'i, Department of Health)

Crude death weight: $\text{Deaths} \times 1000 / \text{Total population}$ (Hawai'i, Department of Health)

Curfew and loitering:

Included are violations of local curfew or loitering ordinances. (Hawai'i, Department of the Attorney General)

Disorderly conduct:

Committing a breach of the peace. Includes affray; unlawful assembly; disturbing the peace; disturbing meetings; and blasphemy, profanity, and obscene language. (Hawai'i, Department of the Attorney General)

Divorce rate: $\text{Divorces} \times 1000 / \text{Total population}$ (Hawai'i, Department of Health)

Driving under the influence:

Driving or operating any vehicle or common carrier while drunk or under the influence of intoxicants. (Hawai'i, Department of the Attorney General)

Drug abuse violations:

Include all violations of state and local laws relating to the unlawful possession, sale, use, growing, manufacturing, and making of illegal drugs. (Hawai'i, Department of the Attorney General)

Embezzlement:

Misappropriation or misapplication of money or property entrusted to one's care, custody, or control. (Hawai'i, Department of the Attorney General)

Employed:

All civilians 16 years old and over who were either (1) "at work" -- those who did not work at all during the reference week as paid employees, worked in their own business or profession, worked on their own farm, or worked 15 hours or more as unpaid workers on a family farms or in a family business; or (2) were "with job but not at work" -- those who did not work during the reference week but had jobs or businesses from which they were temporarily absent due to illness, bad weather, industrial dispute, vacation, or other personal reasons. Excluded from the employed are persons whose only activity consisted of work around the house of unpaid volunteer work for

religious, charitable, and similar organizations; also excluded are persons on active duty in the United States Armed Forces. (U.S. Census Bureau)

Employment and Training:

The Employment and Training (E&T) program is a statewide work program designed to assist able-bodied adults to become attached to the workforce. E&T serves Food Stamp recipients and puts emphasis on: employment, work experience, training, on-the-job training, and limited job search activities. E&T also provides supportive services in the form of a participant reimbursement to cover work-related expenses and child care. (Hawai'i, Department of Human Services)

Family:

A family consists of a householder and one or more other persons living in the same household who are related to the householder by birth, marriage, or adoption. All persons in a household are related to the household are regarded as members of his or her family. A household can contain only one family for purposes of census tabulations. Not all households contain families since a household may comprise a group of unrelated persons or one person living alone. (U.S. Census Bureau)

Family income:

In compiling statistics on family income, the incomes of all members 15 years old and over in each family are summed and treated as a single amount. (U.S. Census Bureau)

Fetal death rate:

Fetal deaths x 1000 / (Live births + Fetal deaths) (Hawai'i, Department of Health)

Fetal death ratio:

Fetal deaths x 1000 / Live births (Hawai'i, Department of Health)

Forcible rape:

The carnal knowledge of a female forcibly and against her will. Assaults or attempts to commit rape by force or threat of force are also included. Statutory rape (without force), any sexual assaults against males, and other sex offenses are not included in this category. (Hawai'i, Department of the Attorney General)

Forgery and counterfeiting:

All offenses dealing with the making, altering, uttering, or possession of, with the intent to defraud, anything else false in the semblance of what is true. (Hawai'i, Department of the Attorney General)

Fraud:

Fraudulent conversion and obtaining money or property by false pretenses. Includes bad checks (except forgeries and counterfeiting), confidence games, and unauthorized withdrawal of money from an automatic teller machine. (Hawai'i, Department of the Attorney General)

Gambling:

Promoting, permitting, or engaging in illegal gambling. Includes 3 subcategories: bookmaking, numbers and lottery, and "other" gambling. (Hawai'i, Department of the Attorney General)

General Assistance:

The General Assistance program provides cash benefits for food, clothing, shelter, and other essentials to adults between the ages of 18 and 64, without minor dependents, who are disabled and who do not qualify for Social Security. To be eligible, the adult must have little or no income,

not qualify for a federal category of assistance, and be certified by a DHS medical board to be unable to engage in any substantial employment of at least thirty hours per week for a period of at least sixty days. (Hawai'i, Department of Human Services)

General fertility rate:

Live births x 1000 / Population of women 15 to 44 years of age (Hawai'i, Department of Health)

General pregnancy rate:

(Live births + Fetal deaths + abortions) / Population of women 15 to 44 years of age (Hawai'i, Department of Health)

Government workers:

Includes persons who were employees of any local, State, or Federal government unit, regardless of the activity of the particular agency. (U.S. Census Bureau)

Head count:

The number of inmates on a specific date who were physically in custody in one of Hawai'i's correctional facilities. (Hawai'i, Department of Public Safety)

Household:

A household includes all the persons who occupy a housing unit. A housing unit is a house, an apartment, a mobile home, a group of rooms, or a single room that is occupied (or if vacant, is intended for occupancy) as separate living quarters. The occupants may be a single family, one person living alone, two or more families living together, or any other group of related or unrelated persons who share living arrangements. (U.S. Census Bureau)

Household income:

Includes the income of the householder and all other persons 15 years old and over in the household, whether related to the householder or not. Because many households consist of only one person, average household income is usually less than average family income. (U.S. Census Bureau)

Householder:

One person in each household is designated as the householder. In most cases, this is the person, or one of the persons, in whose name the home is owned, being bought, or rented and who is listed in column 1 of the census questionnaire. If there is no such person in the household, any adult household member 15 years and older could be designated as the householder. (U.S. Census Bureau)

Housing unit:

A housing unit is a house, an apartment, a mobile home or trailer, a group of rooms or a single room occupied as a separate living quarters, or, if vacant, intended for occupancy as separate living quarters. Separate living quarters are those in which the occupants live and eat separately from any other persons in the building and which have direct access from outside the building or through a common hall. (U.S. Census Bureau)

Improved lots:

Improved vacant lots (with no house). A community would be developed with infrastructure brought up to County standards. Lots would be awarded with the requirement for the lessee to build their house. (Department of Hawaiian Home Lands)

Income of households:

Includes the income of the householder and all other persons 15 years old and over in a

household, whether related to the householder or not. Because many households consist of only one person, average household income is usually less than average family income. (U.S. Census Bureau)

Income deficit:

Represents the difference between the total income of families and unrelated individuals below the poverty level and their respective poverty thresholds. (U.S. Census Bureau)

Infant death:

An infant death is the death of a live-born child before his or her first birthday. Deaths in the first year of life may be further classified according to age as neonatal and post-neonatal. Neonatal deaths are those that occur before the 28th day of life; post-neonatal deaths are those that occur between 28 and 365 days of age. (U.S. Department of Health and Human Services)

Inmate Population:

Inmates in Hawai'i's state correctional facilities are comprised of three major types of custody status: sentenced felons; sentenced jail; and pretrial. (Hawai'i, Department of Public Safety)

Juvenile:

Person under the age of 18.

Kalawao County:

Census Tract 319. In reports by the Hawai'i State and Maui County governments, Kalaupapa Settlement is included as part of Maui County. The U.S. Bureau of the Census classifies Kalaupapa Settlement as a county, Kalawao county, independent and separate from Maui County. In Census Bureau reports, Maui County data does not include Kalaupapa. Kalaupapa data is reported under Kalawao county, or is omitted due to the limited data. (U.S. Census Bureau)

Labor force:

All persons classified in the civilian labor force plus members of the U.S. Armed Forces. (U.S. Census Bureau)

Larceny-theft:

The unlawful taking, carrying, leading, or riding away of property from the possession or constructive possession of another. Includes pocket-picking, purse-snatching, shoplifting, theft from motor vehicles, theft of motor vehicle parts and accessories, theft of bicycles, etc. Does not include embezzlement, forgery, or motor vehicle theft. (Hawai'i, Department of the Attorney General)

Life expectancy:

Life expectancy is the average number of years of life remaining to a person at a particular age and is based on a given set of age-specific death rates, generally the mortality conditions existing in the period mentioned. Life expectancy may be determined by race, sex, or other characteristics using age-specific death rates for the population with that characteristic. (U.S. Department of Health and Human Services)

Liquor laws:

Include unlawful manufacture, sale, transporting, furnishing, possessing intoxicating liquor; maintaining unlawful drinking places; bootlegging; operating a still; furnishing liquor to a minor; and drinking on a train or public conveyance. Does not include Drunkenness and Driving Under the Influence. (Hawai'i, Department of the Attorney General)

Low birth weight mortality rate:

Infant deaths of low birth weight (under 2500 grams) x 1000 / Live births of low birth weight (Hawai'i, Department of Health)

Manslaughter by negligence:

The killing of another person through gross negligence. Manslaughter by negligence is considered a Part I offense but is not included in the Crime Index. (Hawai'i, Department of the Attorney General)

Marital Status:

Marital status classification of persons 15 years and over at the time of enumeration. (U.S. Census Bureau)

Marriage rate:

Marriages x 1000 / Total population (Hawai'i, Department of Health)

Maternal mortality rate:

Maternal deaths x 100,000 / Live births (Hawai'i, Department of Health)

Motor vehicle theft:

The theft or attempted theft of a motor vehicle, including automobiles, trucks, buses, motorcycles, motor scooters, snowmobiles, etc. (Hawai'i, Department of the Attorney General)

Murder:

The willful (non-negligent) killing of one human being by another. (Hawai'i, Department of the Attorney General)

Neonatal mortality rate:

Infant deaths under 28 days x 1000 Live births (Hawai'i, Department of Health)

Nonviolent offenses:

Include the offense categories of larceny-theft, burglary, and auto theft. Often referred to as Property Offenses (excluding robbery). (Hawai'i, Department of the Attorney General)

Occupied housing unit:

A housing unit is classified as occupied if it is the usual place of residence of the person or group of persons living in it at the time of enumeration, or if the occupants are only temporarily absent; that is, away on vacation. If all the persons staying in the unit at the time of the census have their usual place of residence elsewhere, the unit is classified as vacant. (U.S. Census Bureau)

Offenses against the family and children:

Include all charges of nonsupport and neglect or abuse of family and children. Examples include desertion, abandonment, or nonsupport of spouse or child; neglect or abuse of spouse or child; and nonpayment of alimony. (Hawai'i, Department of the Attorney General)

Out marriage:

Marriage to a person of a different ethnic background. (Hawai'i, Department of Health)

Owner occupied housing unit:

A housing unit is owner occupied if the owner or co-owner lives in the unit even if it is mortgaged or not fully paid for. (U.S. Census Bureau)

Part I offenses:

Offenses which make up the Crime Index: murder, forcible rape, robbery, aggravated assault,

burglary, larceny-theft, motor vehicle theft, and arson; plus the offense of manslaughter by negligence. (Hawai'i, Department of the Attorney General)

Part II offenses:

All criminal offenses not classified as Part I offenses. Also included are the juvenile status offenses of curfew/loitering violation and runaway. (Hawai'i, Department of the Attorney General)

Per capita income:

Per capita income is the mean income computer for every man, women, and child in a particular group. It is derived by dividing the total income of a particular group by the total population in that group (excluding patients or inmates in institutional quarters). (U.S. Census Bureau)

Perinatal mortality rate:

(Infant deaths under 1 week of age + Fetal deaths of 20 weeks or more gestation) x 1000 / Live births (Hawai'i, Department of Health)

Perinatal mortality ratio:

(Infant deaths under 1 week of age + Fetal deaths of 20 weeks or more gestation) x 1000 / Live births (Hawai'i, Department of Health)

Personal income:

Income received by all individuals in an economy from all sources, made up of wages and salaries, other labor income, and the difference between transfer payments and personal contributions for social insurance. (U.S. Census Bureau)

Postneonatal mortality rate:

Infant deaths over 27 days x 1000 / Live births (Hawai'i, Department of Health)

Poverty guidelines:

The poverty guidelines are the other version of the federal poverty measure. They are issued each year in the Federal Register by the U.S. Department of Health and Human Services. The guidelines are a simplification of the poverty thresholds for use for administrative purposes—for instance, determining financial eligibility for certain federal programs. (U.S. Census Bureau)

Poverty thresholds:

Poverty statistics are based on definitions originally developed by the Social Security Administration. These include a set of money income thresholds that vary by family size and composition. Families or individuals with income below their appropriate thresholds are classified as below the poverty level. These thresholds are updated annually by the U.S. Census Bureau to reflect changes in the Consumer Price Index for all urban consumers (CPI-U). The thresholds are used mainly for statistical purposes—for instance, preparing estimates of the number of Americans in poverty each year. (U.S. Census Bureau)

Pretrial inmates:

Consists of pretrial felons, pretrial misdemeanants, and Federal detainees awaiting trial, pretrial release, or transfer. Their length of detention varies from one day to several months. (Hawai'i, Department of Public Safety)

Property offenses:

Include larceny-theft, burglary, auto theft, and arson. Robbery is classified as a violent crime due to the use or threat of force. (Hawai'i, Department of the Attorney General)

Prostitution and commercialized vice:

Sex offenses in a commercialized nature. Include prostitution; keeping a bawdy house, disorderly house, or house of ill fame; pandering, procuring, transporting, or detaining women for immoral purposes, etc.; and all attempts. (Hawai'i, Department of the Attorney General)

Renter occupied housing unit:

All occupied housing units which are not owner occupied, whether they are rented for cash or occupied without payment of cash rent, are classified as renter occupied. (U.S. Census Bureau)

Resident Population:

The number of persons whose usual place of residence is in an area, regardless of physical location on the estimated census date. Includes military personnel stationed or homeported in the area and excludes persons of local origin attending school or in military service outside the area. (Hawai'i, Department of the Attorney General)

Robbery:

The taking or attempting to take anything of value from the care, custody, or control of a person or persons by force or threat of force or violence and/or by putting the victim(s) in fear. While robbery has the attributes of a property crime, it is grouped with violent crimes due to the additional attribute of force or the threat of force. (Hawai'i, Department of the Attorney General)

Runaways:

Apprehension for protective custody as defined by local statute. (Hawai'i, Department of the Attorney General)

Rural lots:

Undeveloped rural lots in higher rainfall area of approximately one-acre size. Rural standards are defined as having an individual wastewater facility, individual water catchment system, and rural road improvements (no curb and gutters). (Department of Hawaiian Home Lands)

Self-employed workers:

Includes persons who worked for profit or fees in their own unincorporated business, profession, or trade, or who operated a farm. (U.S. Census Bureau)

Sentenced felons:

Are inmates who serve prison terms exceeding one year. It also includes probation and parole violators since this group is generally detained with the sentenced felon population. (U.S. Census Bureau)

Sentenced jail inmates:

Include sentenced misdemeanants and sentenced felon probationers who serve jail terms of one year or less. (Hawai'i, Department of Public Safety)

Sex offenses:

Include indecent exposure, incest, statutory rape (no force), any sexual assaults against males, other offenses against common decency and morals, and all attempts. Do not include forcible rape, prostitution, and commercialized vice. (Hawai'i, Department of the Attorney General)

Status offenses (persons under 18):

Non-criminal acts or conduct which are offenses only when committed or engaged in by juveniles; include curfew violation and runaways. (Hawai'i, Department of the Attorney General)

Stolen property:

Buying, receiving, and possessing of stolen property, including attempts. (Hawai'i, Department of the Attorney General)

Suspicion:

While "suspicion" is not an offense, it may be the grounds for many arrests in those jurisdictions where the law permits. After examination by law enforcement officers, the prisoner is either formally charged or released. Those formally charged are entered in one of the Part I or Part II offense classes. This class is limited to "suspicion" arrests where persons arrested are released by the police. (Hawai'i, Department of the Attorney General)

TANF:

Temporary Assistance for Needy Families. Limited-time welfare programs for adults with children designed to protect those who cannot work and require those who are able to do so. TANF provides monthly cash benefits to families for food, clothing, shelter, and other essentials. In families in which all members are U.S. citizens and no child has two legal parents residing in the home, the family is eligible for federally funded welfare under TANF. (Hawai'i, Department of Human Services)

TANOF:

Temporary Assistance for Other Needy Families. Limited-time welfare programs for adults with children designed to protect those who cannot work and require those who are able to do so. TANOF provides monthly cash benefits to families for food, clothing, shelter, and other essentials. Families which include at least one non-citizen or in which at least one child has both of his or her parents residing in the home are eligible for state-funded welfare under TANOF. (Hawai'i, Department of Human Services)

Technical violator:

Custody status of inmates who are or were held as a result of violating the terms and/or conditions of their parole or probation. (Hawai'i, Department of Public Safety)

Turnkey lots:

Turnkey or lots with single family homes. Applicants would have a choice on the model type single-family dwelling. (Department of Hawaiian Home Lands)

Unemployed:

All civilians 16 years and over are classified as unemployed if they (1) were neither "at work" nor "with a job but not at work" during the reference week, and (2) were looking for work during the last 4 weeks, and (3) were available to accept a job. Also included as unemployed are civilians who did not work at all during the reference week and were waiting to be called back to a job from which they had been laid off. (U.S. Census Bureau)

Unemployment rate:

A ratio of unemployed persons divided by the civilian labor force.

Undivided interest:

Unimproved lots with undivided interest. Group interest in a subdivision project. When project is subdivided into individual lots, selection process begins. (Department of Hawaiian Home Lands)

Vacant housing unit:

A housing unit is vacant if no one is living in it at the time of enumeration, unless its occupants are only temporarily absent. Units temporarily occupied at the time of enumeration entirely by persons who have a usual residence elsewhere are also classified as vacant. (U.S. Census Bureau)

Vagrancy:

Persons arrested on grounds of "suspicion" may be prosecuted on this charge. Includes vagrancy, begging, loitering (persons 18 and over), and vagabondage. (Hawai'i, Department of the Attorney General)

Vandalism:

The willful or malicious destruction, injury, disfigurement, or defacement of any public or private property, real or personal, without consent of the owner or person having custody or control by cutting, tearing, breaking, marking, painting, drawing, covering with filth, or any other such means as may be specified by local law. (Hawai'i, Department of the Attorney General)

Violent offenses:

Include the offense categories of murder, forcible rape, robbery, and aggravated assault. (Hawai'i, Department of the Attorney General)

Weapons offenses:

Include unlawful manufacture, sale, or possession of deadly weapons; unlawful carrying of deadly weapons, concealed or openly; using, manufacturing, etc. silencers; furnishing deadly weapons to a minor; and all attempts to commit any of the above. (Hawai'i, Department of the Attorney General)

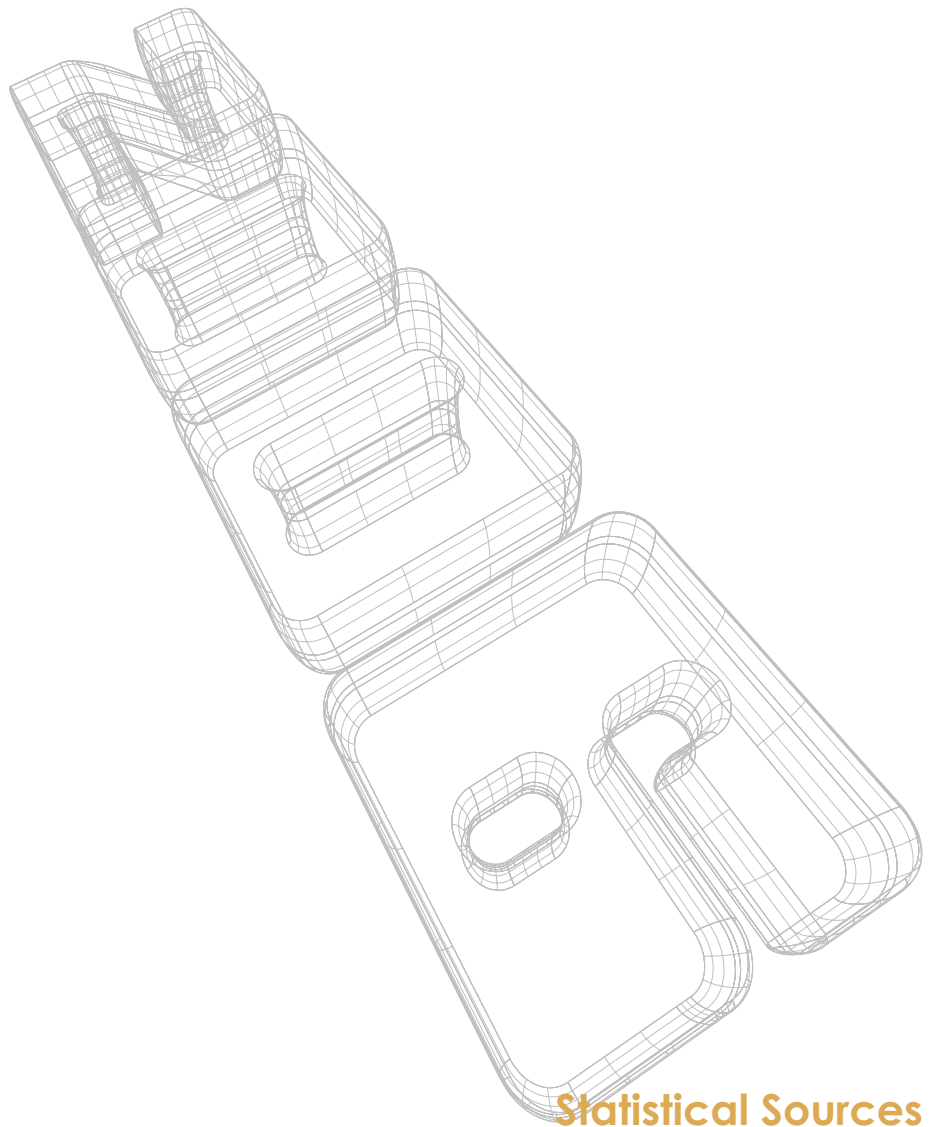

Statistical Sources

SOURCES OF STATISTICAL INFORMATION

1. Department of Hawaiian Home Lands (DHHL):

<http://www.hawaii.gov/dhhl>

Department of Hawaiian Home Lands Beneficiary Study, prepared by SMS Research and Marketing Services, Inc. January, 2004.

2. State of Hawai'i Department of the Attorney General:

<http://www.state.hi.us/ag>

3. State of Hawai'i Department of Health (DOH):

Alcohol and Drug Abuse Division

<http://www.hawaii.gov/health/substance-abuse>

Behavior Risk Factor Surveillance System (BRFSS)

<http://www.hawaii.gov/health/statistics/brfss/index.html>

Hawai'i Health Survey (HHS)

<http://www.hawaii.gov/health/statistics/hhs/index.html>

Office of Health Status Monitoring

<http://www.hawaii.gov/health/statistics/vital-statistics/index.html>

4. State of Hawai'i Department of Human Services (DHS):

<http://www.hawaii.gov/dhs>

5. State of Hawai'i Department of Public Safety (PSD):

<http://www.hawaii.gov/psd>

6. State of Hawai'i Office of Elections

<http://www.hawaii.gov/elections>

7. Kamehameha Schools:

Policy Analysis and System Evaluation (PACE)

<http://www.ksbe.edu/pace/default.php>

8. Office of Hawaiian Affairs:

<http://www.oha.org>

9. University of Hawai'i:

Institutional Research Office

<http://www.hawaii.edu/iro/maps.htm>

10. U.S. Government:

<http://www.census.gov>

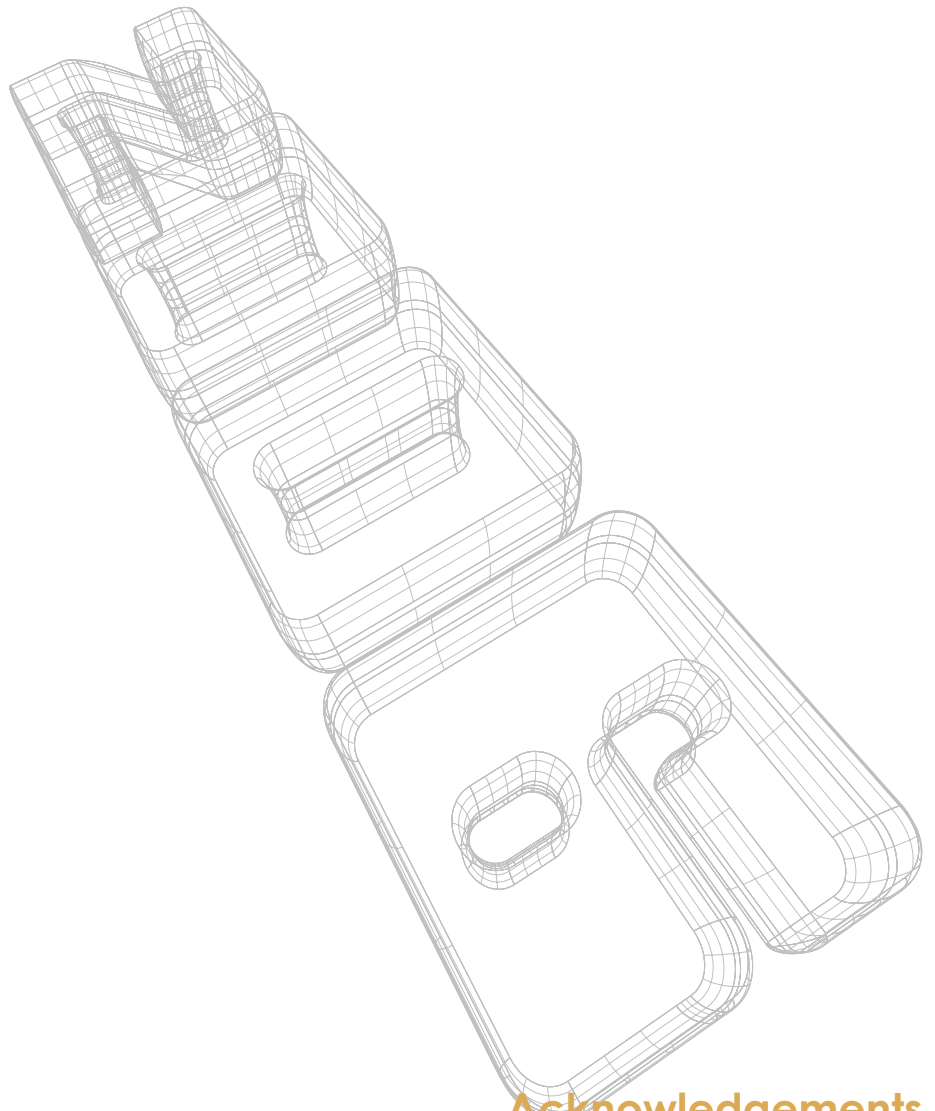

Acknowledgements

ACKNOWLEDGEMENTS

We wish to thank the many public and private agencies that provided data and proofing assistance. Without the efforts of their research personnel, this book would not have been possible.

- Lea Young

Office of Hawaiian Affairs:

Manu Boyd
Reshela DuPuis
Mark B. Glick
Kathryn Keala
Kai Markell
John Matsuzaki
Michael McDonald
Steve Morse
Ka'imo Muhlestein
Analika Nahulu
'Aukai Reynolds
Rona Rodenhurst
Alika Young

State of Hawai'i:

Department of the Attorney General
Department of Health
Department of Human Services
Department of Public Safety
University of Hawai'i System

Elmer Ka'ai,
Department of Hawaiian Homelands

Shawn Kana'iaupuni,
and the Kamehameha Schools' PASE team

Renee Louis,
GIS Consultant

Jan Nakamoto,
**Department of Business
and Economic Development**

